

I-V Photo IC for CD Player

Description

The CXA1753M is a photo IC developed as a photodetector for the optical pickup of CD players.

It has a built-in I-V amplifier, and features low output impedance for stable output.

- Focus servo : astigmatic method
- Tracking servo : three-spot method

Features

- I-V amplifier (current-voltage conversion circuit)
- Compact transparent molded package (SOP)
Identical to the shape of conventional photodiodes

Applications

Optical pickup of CD players

Structure

Bipolar silicon monolithic IC

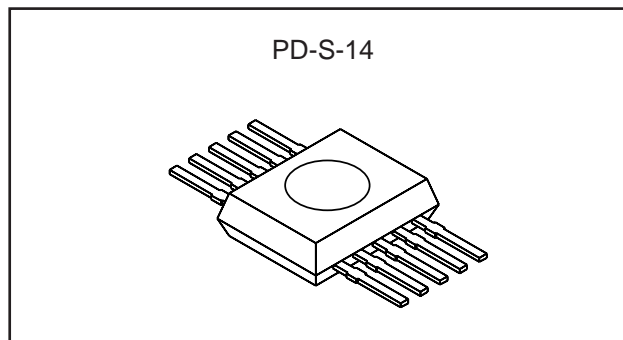
**Absolute Maximum Ratings** (Ta=25 °C)

• Supply voltage	V _{CC}	12	V
• Operating temperature	T _{opr}	-20 to +75	°C
• Storage temperature	T _{stg}	-40 to +85	°C
• Allowable power dissipation	P _D	200	mW

Operating Conditions

Supply voltage	V _{CC}	2.8 to 11.0	V
----------------	-----------------	-------------	---

Sony reserves the right to change products and specifications without prior notice. This information does not convey any license by any implication or otherwise under any patents or other right. Application circuits shown, if any, are typical examples illustrating the operation of the devices. Sony cannot assume responsibility for any problems arising out of the use of these circuits.

Electrical and Optical Characteristics I

(V_{CC}=3.0 V, V_C=1.5 V, T_a=25 °C)

Item	Symbol	Conditions	Min.	Typ.	Max.	Unit
Current consumption	I _{CC}	In the dark	—	2.0	2.8	mA
Output offset voltage (A-F)	V _{off}	In the dark	-15	0	15	mV
Output offset voltage difference	ΔV _{off}	(A+B) – (C+D) In the dark	-15	0	15	mV
		(A+D) – (B+C) In the dark	-15	0	15	mV
		(A+C) – (B+D) In the dark	-15	0	15	mV
		E–F In the dark	-10	0	10	mV
Output voltage (A-D)	V _O	P _O =10 μW, λ=780 nm	290	370	450	mV
Output voltage (E, F)	V _O	P _O =10 μW, λ=780 nm	610	770	930	mV
Maximum output voltage (A-D)	V _{Omax}	P _O =100 μW, λ=780 nm	2.0	2.2	—	V
Maximum output voltage (E, F)	V _{Omax}	P _O =100 μW, λ=780 nm	2.5	2.9	—	V
Frequency response (A-D)	f _c	100 kHz reference, -3 dB	2.0	3.0	—	MHz
Frequency response (E, F)	f _c	10 kHz reference, -3 dB	100	400	—	kHz

Electrical and Optical Characteristics II

(V_{CC}=5.0 V, V_C=2.5 V, T_a=25 °C)

Item	Symbol	Conditions	Min.	Typ.	Max.	Unit
Current consumption	I _{CC}	In the dark	—	3.5	4.5	mA
Output offset voltage (A-F)	V _{off}	In the dark	-15	0	15	mV
Output offset voltage difference	ΔV _{off}	(A+B) – (C+D) In the dark	-15	0	15	mV
		(A+D) – (B+C) In the dark	-15	0	15	mV
		(A+C) – (B+D) In the dark	-15	0	15	mV
		E–F In the dark	-10	0	10	mV
Output voltage (A-D)	V _O	P _O =10 μW, λ=780 nm	290	370	450	mV
Output voltage (E, F)	V _O	P _O =10 μW, λ=780 nm	610	770	930	mV
Maximum output voltage (A-D)	V _{Omax}	P _O =100 μW, λ=780 nm	4.0	4.2	—	V
Maximum output voltage (E, F)	V _{Omax}	P _O =100 μW, λ=780 nm	4.5	4.9	—	V
Frequency response (A-D)	f _c	100 kHz reference, -3 dB	2.0	2.5	—	MHz
Frequency response (E, F)	f _c	10 kHz reference, -3 dB	100	400	—	kHz

Note 1 : V_C is reference for output voltage and output offset voltage.

Note 2 : GND is reference for maximum output voltage.

Note 3 : Output voltage and frequency response are subject to confirmation of design.

Measurement Circuit

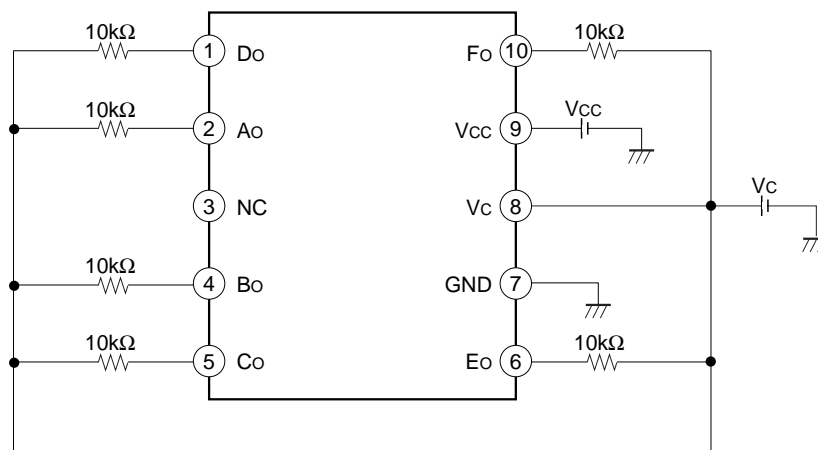

Photodetector position

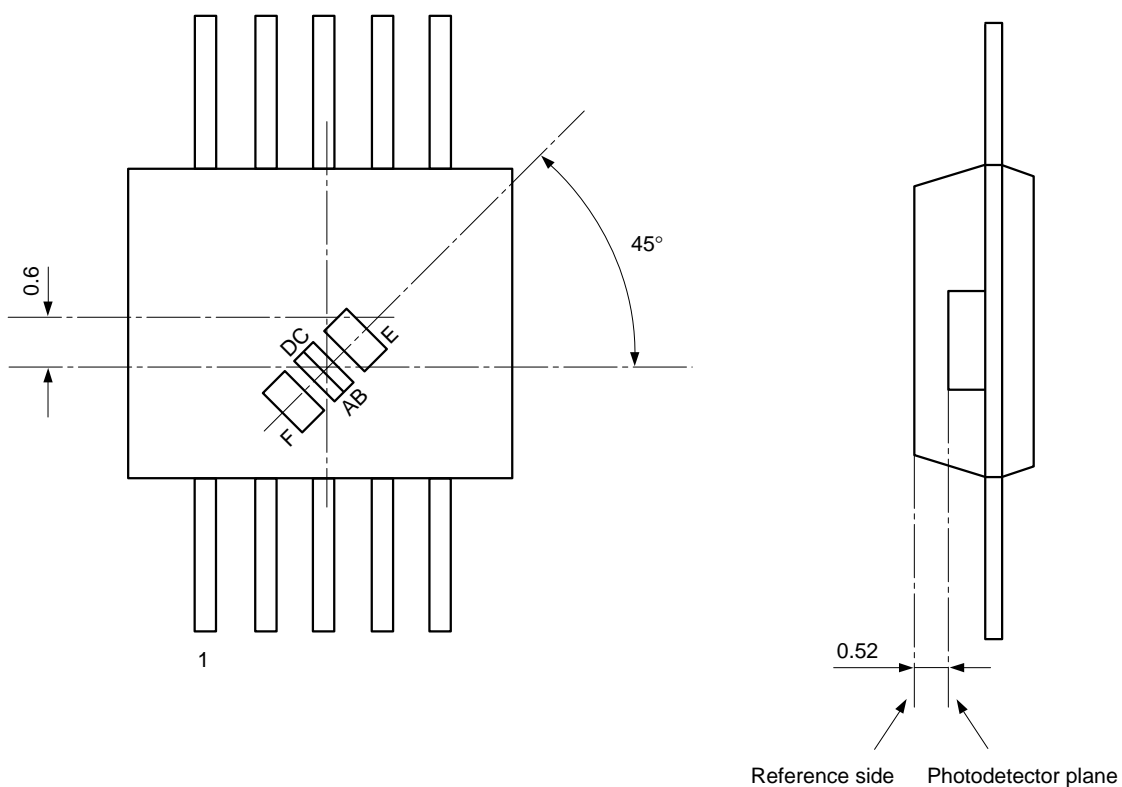

Tolerance in position of photodetector center

- X, Y : ± 0.2
- Z : ± 0.2
- θ : $\pm 2^\circ$

(Unit : mm)

Photodetector Pattern Dimensions

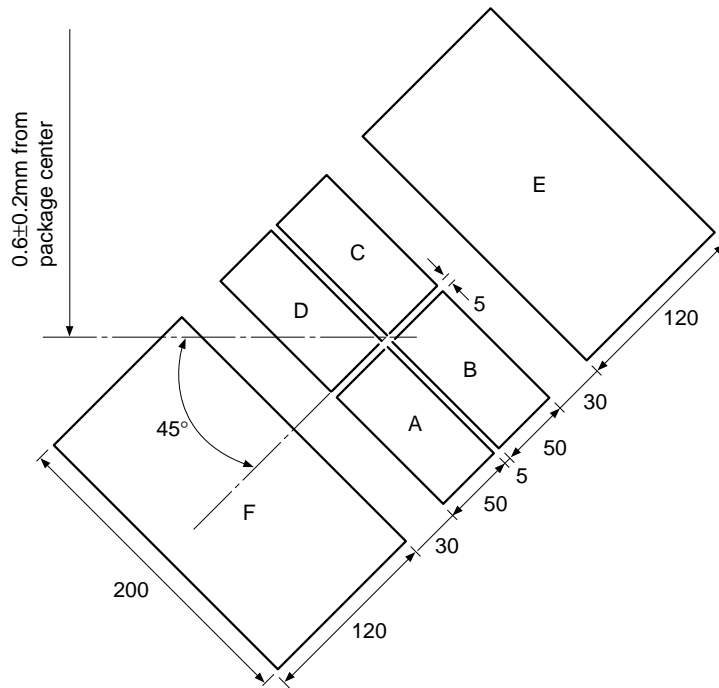

(Unit : μm)

Circuit Block Diagram

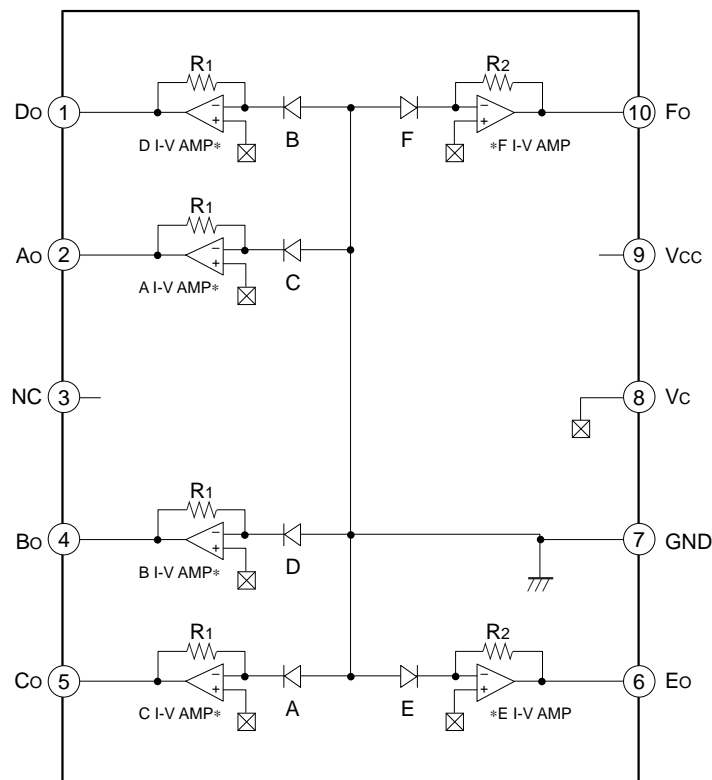

R1=166kΩ, R2=334kΩ
A, B, C, D, E and F are photodiodes

Pin Description

Pin No.	Symbol	I/O	Equivalent circuit	Description
1 2 4 5	Do Ao Bo Co	O		Output of voltage signals converted from optical signals.
3	NC			Common with GND for the package construction.
6 10	Eo Fo	O		Output of voltage signals converted from optical signals.
7	GND	I		For a dual power supply : negative power supply For a single power supply : GND
8	Vc	I		For a dual power supply : GND For a single power supply : center voltage input
9	Vcc	I		Positive power supply

Notes on Operation

1. Connection to RF amplifiers

The CXA1753M features the voltage-output type and the voltage-input type such as the CXA1610M should be used as RF amplifiers. The noise tolerance will be greatly improved over that of conventional photodiodes used with current-input RF amplifiers.

2. Power supply

The CXA1753M can be used either with a dual power supply or with a single power supply.

However, this IC is not provided with a center voltage generating circuit, and so when used with a single power supply the center voltage must be supplied by an RF amplifier or some other device. For instance when the CXA1610M is used as an RF amplifier, the V_c input pin of the CXA1753M should be connected to the VR output pin of the CXA1610M.

In addition, note that Pin 3 is internally connected to Pin 7 (GND).

Power supply connections for each case are as follows.

	(9) V _{CC}	(7) GND	(8) V _c	(3) NC
Dual power supply	Positive power supply	Negative power supply	GND	Negative power supply or open
Single power supply	Positive power supply	GND	Center voltage	GND or open

For both a dual power supply and a single power supply, the voltage difference between the V_{CC} and GND pins should be within the range of 2.8 V and 11.0 V.

Package Outline Unit : mm

PD-S-14

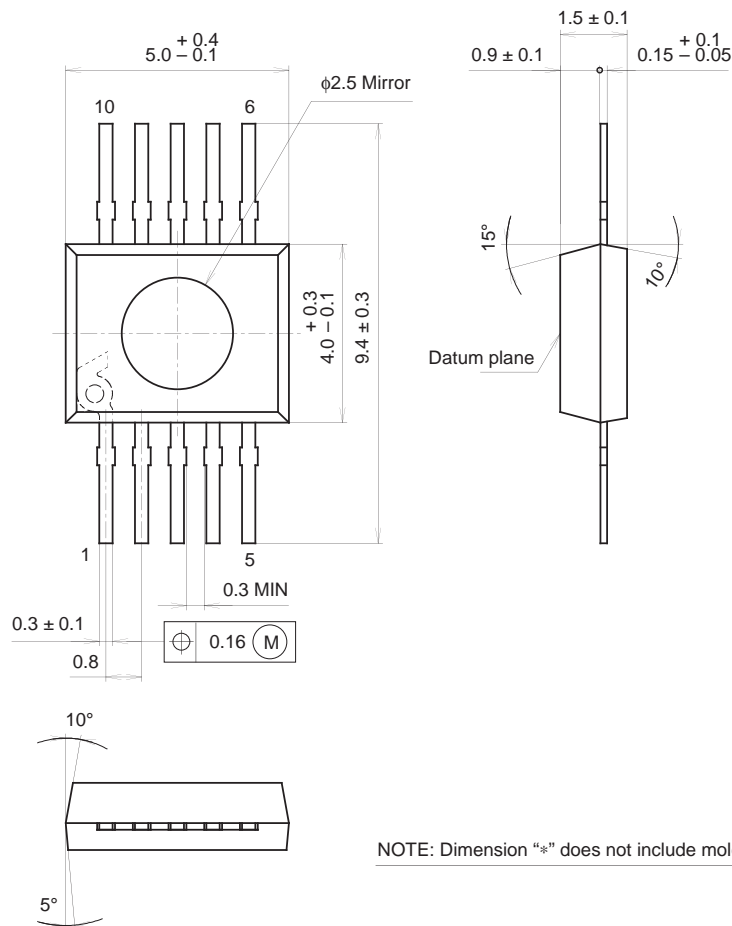

NOTE: Dimension "*" does not include mold protrusion.

SONY CODE	PD-S-14
EIAJ CODE	_____
JEDEC CODE	_____

PACKAGE WEIGHT	0.06g
----------------	-------



LittleDiode supplies new, hard to find or obsolete electronic components and semiconductors all over the world.

With over two million different components listed you are sure to find the part you need.

Feel free to visit us today at our online store:

LittleDiode.com

Looking forward to providing you with the best possible service.