

IF Amplifier for Analog Cellular Communications

Description

The CXA1742Q is an analog cellular(AMPS) FM IF IC which include an IF filter.

Features

- Include a ceramic filter function, which is normally mounted externally.
- Quadrature detection discriminator function.
- This IC has almost all IF functions and is ideal for reduction in set size because of few external parts required.
- Channel filter conforming to the AMPS standard.
- Wide operating voltage range (2.7 V to 3.6 V) and low current consumption (Icc=10 mA (typ.) when Vcc= 3 V).
- Wide range and excellent temperature characteristics for the RSSI (receiving signal strength indicator).

Applications

Ideally suited for cellular phones, particularly hand-held sets.

Structure

Bipolar silicon monolithic IC

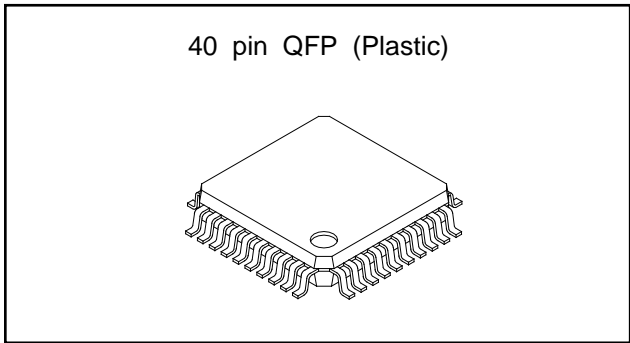

Absolute Maximum Ratings (Ta = 25°C)

- Supply voltage VCC 5 V
 - Operating temperature Topr -35 to +85 °C
 - Storage temperature Tstg -65 to +150 °C
 - Allowable power dissipation
- | | | |
|----|-----|----|
| PD | 500 | mW |
|----|-----|----|

Operating Conditions

- | | | | |
|----------------|-----|------------|---|
| Supply voltage | VCC | 2.7 to 3.6 | V |
|----------------|-----|------------|---|

Sony reserves the right to change products and specifications without prior notice. This information does not convey any license by any implication or otherwise under any patents or other right. Application circuits shown, if any, are typical examples illustrating the operation of the devices. Sony cannot assume responsibility for any problems arising out of the use of these circuits.

Block Diagram and Pin Configuration

(Top View)

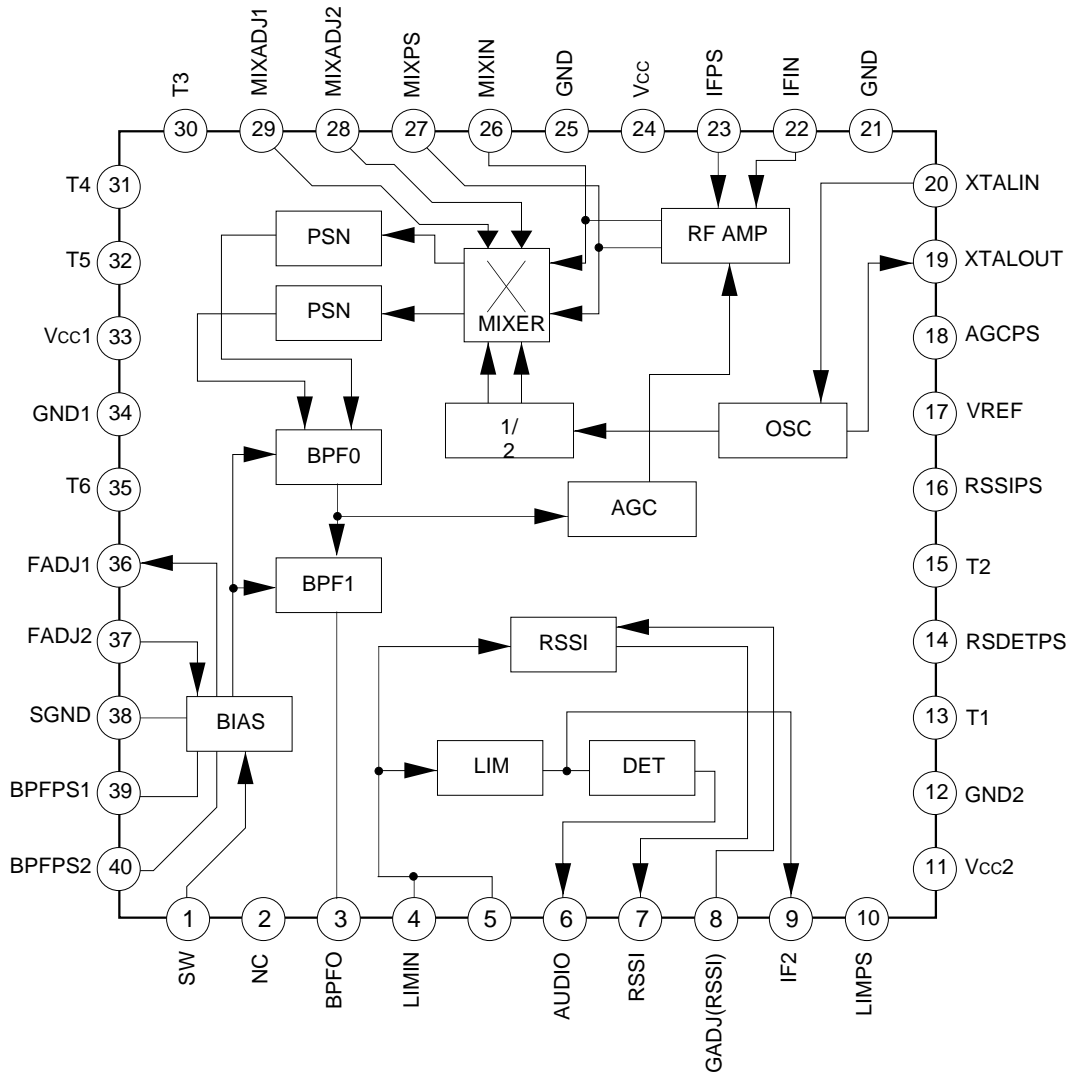

Note) Pins 21 and 25 are connected via the IC internal wiring.

Pins 12, 21 and Pins 25, 34 are connected via IC internal resistors.

When designing a PCB, ensure that all GND pins of IC are connected to the GND on PCB with its connection wiring distance minimized.

Pin No.	Symbol	Pin voltage		I/O resistance	Equivalent circuit	Description
		DC	AC			
1	SW					Used at the GND potential.
2	NC					Not internally connected.
3	BPFO	1.83V				BPF output. Connect to Pins 4,5.
4 5	LIMIN			Open Base		Input of BPF output. The DC bias is applied from pin3 when the output of BPF is connected to them.
6	AUDIO	1.85V				Outputs an AUDIO signal which is FM-detected.

Pin No.	Symbol	Pin voltage		I/O resistance	Equivalent circuit	Description
		DC	AC			
7	RSSI	1.1 V				RSSI output. Outputs a DC voltage in accordance with the signal input to the RF amplifier.
8	GADJ	0.2 V				Adjusts the RSSI amplifier gain.
9	IF2	1.07 V				Limiter operation monitor. Not used normally.
10	LIMPS	1.82 V				Connects a limiter integrating capacitor.

Pin No.	Symbol	Pin voltage		I/O resistance	Equivalent circuit	Description
		DC	AC			
11	Vcc2	3.0 V				Power supply. Supplies current to the LIM, DET, and RSSI circuits.
12	GND2	0 V				Ground.
13	T1					IC operation check.
14	RSDETPS	1.35 V				Connects an RSSI detector integrating capacitor.
15	T2					IC operation check.
16	RSSIPS	1.83 V				Connects an RSSI integrating capacitor.
17	VREF	1.25 V				Monitor for the reference voltage used in the internal circuit. When connected to an external capacitor, this pin also functions to lower the reference voltage dynamic impedance.

Pin No.	Symbol	Pin voltage		I/O resistance	Equivalent circuit	Description
		DC	AC			
18	AGCPS	0.233 V				Connects an AGC integrating capacitor.
19	XTALOUT					Connect a crystal oscillator to form a Colpitts-type oscillator circuit. When an external oscillator is used, its signal must be connected to Pin 20.
20	XTALIN	2.96 V				
21	GND	0 V				Ground.
22	IFIN	1.25 V				RF amplifier input. The relationship between IFIN (Pin 22) and IFPS (Pin 23) is designed so that the IC internal stray capacitance is small.
23	IFPS	1.25 V				Therefore, if Pins 22 and 23 are used for balance input, the common-mode rejection deteriorates.
24	Vcc	3.0 V				Power supply. Supplies current to the RF AMP, MIXER, OSC, and 1/2 DIVIDER circuits.
25	GND	0 V				Ground.

Pin No.	Symbol	Pin voltage		I/O resistance	Equivalent circuit	Description
		DC	AC			
26	MIXIN	1.3 V				RF AMP output monitor. Connected to the MIXER input in the IC.
27	MIXPS	1.3 V				
28	MIX ADJ2	0.143 V				Balance adjustment for mixers 1 and 2.
29	MIX ADJ1	0.143 V				
30	T3					IC operational check.
31	T4					
32	T5					
33	Vcc1	3.0 V				Power supply. Supplies current to the PSN, BPF, and BIAS circuits.
34	GND1	0 V				Ground.
35	T6					IC operational check.
36	FADJ1	2.29 V				When the resistance value of an external resistor connected between Pins 36 and 37 is varied, the center frequency of the BPF in the IC changes accordingly.
37	FADJ2	1.55 V				

Pin No.	Symbol	Pin voltage		I/O resistance	Equivalent circuit	Description
		DC	AC			
38	SGND	1.83 V				<p>Monitor for the pseud-ground voltage used in the internal circuits.</p> <p>When connected to an external capacitor, this pin also functions to lower the reference voltage dynamic impedance.</p>
39	BPFPS1	1.17 V				<p>Monitor for the reference voltage used by the BPF.</p> <p>When connected to an external capacitor, these pins also function to lower the reference voltage dynamic impedance.</p>
40	BPFPS2	1.2 V				

Electrical Characteristics

0dBm = 50Ω, 1mW
 Vcc = 3V, Ta = 25°C
 FOSC = 89.88 MHz

Item	Symbol	Conditions	Min.	Typ.	Max.	Unit
Current consumption - 1	ICC-11	fin = 45 MHz, -30 dBm Pin 11	0.8	1.1	1.5	mA
Current consumption - 2	ICC-24	fin = 45 MHz, -30 dBm Pin 24	2	2.8	3.7	mA
Current consumption - 3	ICC-33	fin = 45 MHz, -30 dBm Pin 33	3.6	5.1	6.7	mA
Pin current Pin 1 - Low	IIL	0 V	-14	-10	-7	μA
Pin current Pin 1 - High	IiH	3 V	15	22	30	μA
Pin current Pin 19	I19	Crystal osc. 89.88 MHz		0.4	0.6	mA
Pin voltage - Pin 17	V17		1.2	1.25	1.3	V
Pin voltage - Pin 38	V38		1.7	1.83	1.95	V
Pin voltage - Pin 39	V39		1.05	1.17	1.3	V
Pin voltage - Pin 40	V40		1.07	1.2	1.33	V
OSC output swing Pin 19	VOSC	Crystal osc. 89.88 MHz	70	93	130	mV rms
AMPS mode (Pin 1=Low)						
BPF output voltage - 1	VTG1	fin = 45 MHz, -50 dBm	90	152	220	mV rms
BPF output voltage - 2	VTG2	fin = 45 MHz, -20 dBm	200	260		mV rms
IF1 output voltage	VTIF	fin = 45 MHz, -20 dBm	70	100	130	mV rms
Mixer image rejection level	VIMAG	fin = 44.88 MHz, -30 dBm		30	100	mV rms
BPF 6 dB bandwidth	BW6dB	Vin = -50 dBm, Swept with fin = 45 MHz regarded as the center	29	32	35	kHz
BPF 40 dB bandwidth	BW40dB	Vin = -50 dBm, Swept with fin = 45 MHz regarded as the center		47		kHz
BPF extraband attenuation	ATT40K	fo ±40 kHz		56		dB
FM detection level	FMDET	fin = 45 MHz, -30 dBm, fmod=1 kHz, Dev. = 8 kHz, used LPF 20 kHz	130	166	200	mV rms
AM rejection ratio	AMR	fin = 45 MHz, -30 dBm, fmod = 1 kHz, Mod = 80% used LPF 20 kHz	23	30		dB

Item	Symbol	Conditions	Min.	Typ.	Max.	Unit
Audio output distortion	THD	$f_{in} = 45 \text{ MHz}$, -30 dBm , $f_{mod} = 1 \text{ kHz}$, Dev. = 8 kHz, used LPF 20 kHz		3.2	5.5	%
RSSI output voltage - 11	RSSI ₁₁	No input	1	1.1	1.25	V
RSSI output voltage - 12	RSSI ₁₂	$f_{in} = 45 \text{ MHz}$, -60 dBm	1.65	1.88	2.1	V
RSSI output voltage - 13	RSSI ₁₃	$f_{in} = 45 \text{ MHz}$, -20 dBm	2.4	2.62	2.8	V
Others						
Equivalent input resistance Pin 22	R _{IN}	$f = 45 \text{ MHz}$		1.4		k Ω
Equivalent input capacitance Pin 22	C _{IN}	$f = 45 \text{ MHz}$		4.7		pF
BPF•fo temperature characteristics AMPS mode		T _a = -30 to $+70^{\circ}\text{C}$		1.5		kHz

Application Circuit

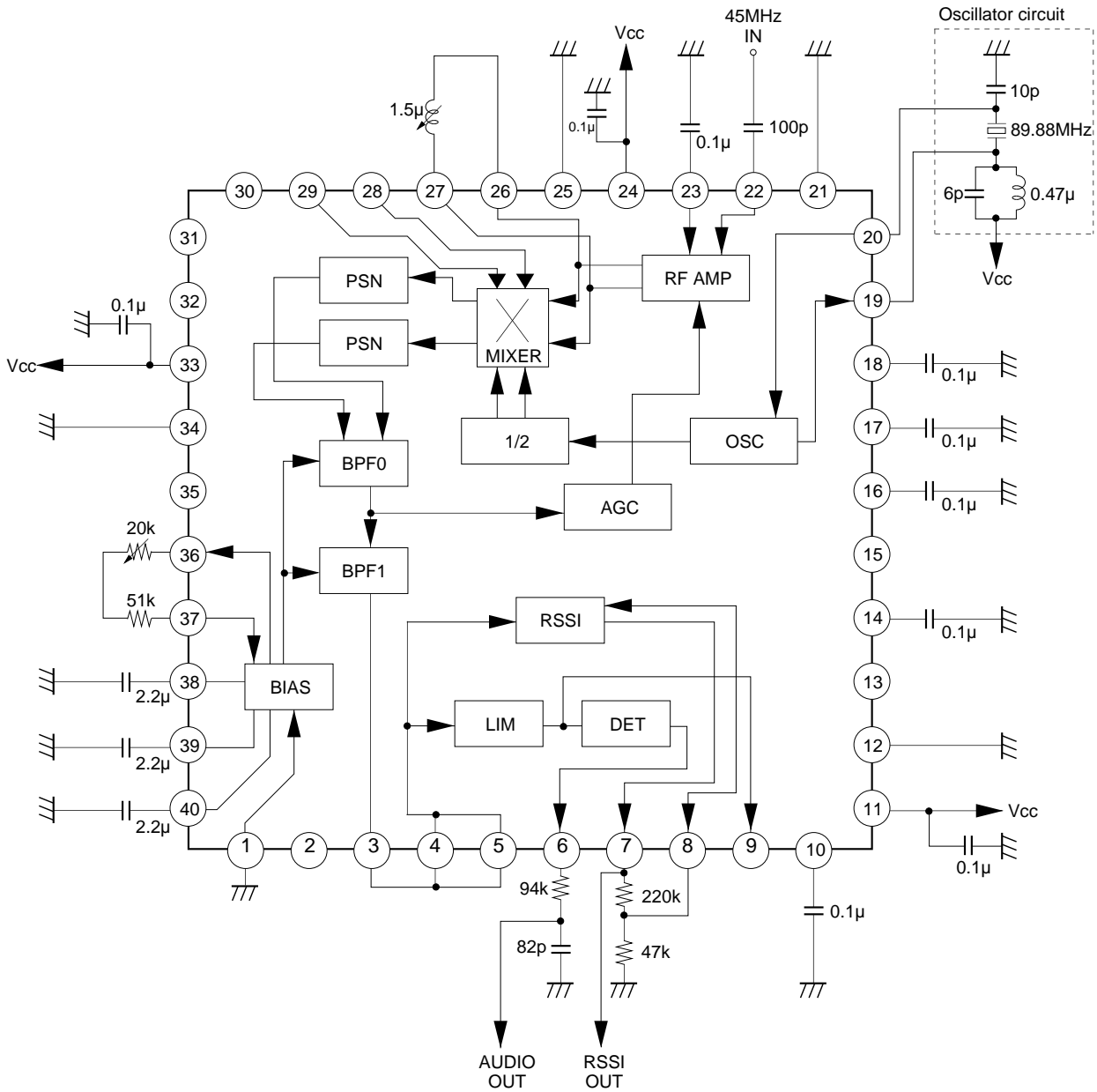

Note) Use a 0.1μF capacitor for Pin 14 decoupling.

The IC malfunctions at a capacitance of 0.047μF or lower.

The oscillator circuit must be changed according to the crystal characteristics.

When designing PCB pattern, make PCB pattern so that Pins 3, 4, and 5 are connected correlatively.

Application circuits shown are typical examples illustrating the operation of the devices. Sony cannot assume responsibility for any problems arising out of the use of these circuits or for any infringement of third party patent and other right due to same.

Description of Operation

A 45 MHz IF signal is input to Pin 22. This input signal is amplified at the RF AMP and then mixed with the local oscillation signals from the oscillator at the mixer to change the signal frequency to 60 kHz. When a crystal or the other resonator circuit is connected to Pins 19 and 20, the oscillator can be self-executed by composing a Colpitts-type oscillation circuit. It can be also used with an external local oscillation signal applied to Pin 20.

The internal BPF eliminates any interference from the converted 60 kHz signal, which is then output to Pin 3. The resulting signal is fed to Pins 4 and 5 to connect to the limiter and RSSI circuits.

The limiter eliminates an amplitude component from the signal. The resulting signal is then detected at the quadrature FM detector circuit, and Pin 6 outputs an audio signal.

The RSSI circuit detects the RF AMP input signal voltage and generates from Pin 7 the DC voltage where the detected voltage value is logarithmically compressed.

The resulting signal is fed to Pins 4 and 5 to connect to the limiter and RSSI circuits.

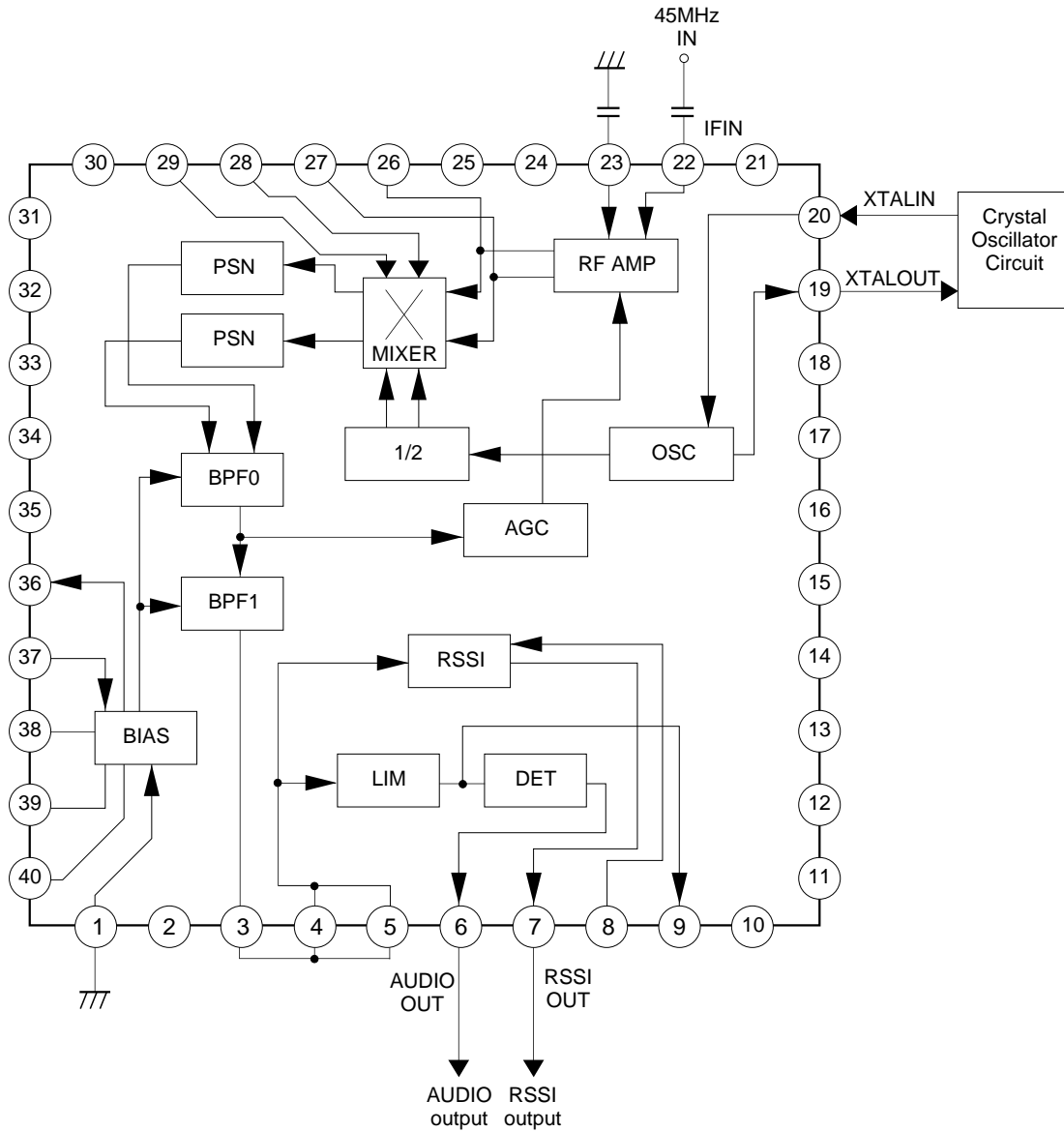

Signal Flow

1) Power supply

Power supply pins (Pins 11, 24, and 33) must be decoupled with the shortest distance.

2) Oscillator

The figures below show how to use the CXA1742Q oscillator.

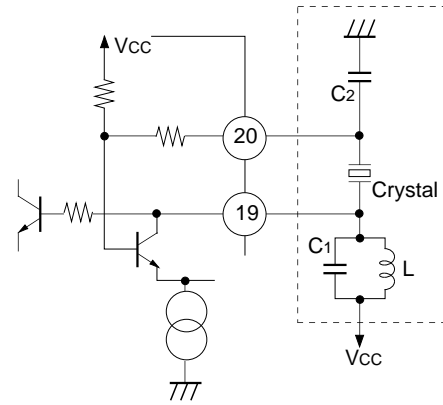
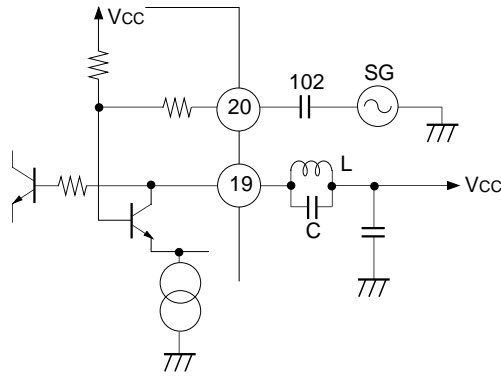

(a) Inputting a local oscillation signal from an external circuit.

The circuit current varies with the externally fed signal amplitude.

The reason is that the AGC circuit, which works to maintain the oscillation amplitude constant when a Colpitts-type oscillator circuit is formed, also operates when an external local oscillation signal is input. Tune the L and C to the Pin 20 input signal frequency or the needed frequency.

The tuning point is decided at the minimum of the Pin 19 current.

Do not decide the point when the probe is connected to Pin 19 because the tuned frequency is deviated by the stray capacitor of the probe.

(b) Configuring a Colpitts-type oscillator circuit.

The C1, C2, and L must be changed according to the crystal characteristics.

The oscillation Tr in the IC is internally subjected to AGC so that the oscillation level at Pin 19 is not likely to be affected by temperature or supply voltage fluctuations.

3) Mixers

Since the BPF in the IC has an fo value as low as 60 kHz, the IC employs an image rejection type of mixer having an enhanced interference elimination capability. Therefore, the two internal mixers must be accurately adjusted so that their gains are equal. Normally, an adequate degree of image rejection is provided without using Pins 28 and 29. However, when they are used for adjustment purposes, an increased degree of image rejection will result.

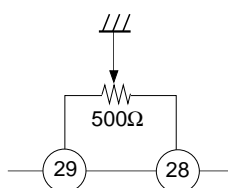

4) BPF

The passband frequency of the built-in filter should be adjusted.

For adjustment method, adjust skirt characteristics of band-pass filter to be symmetric with respect to the center frequency. Or observe the AUDIO output at Pin 7 and adjust the variable resistor between Pins 36 and 37 so as to minimize the AUDIO output distortion.

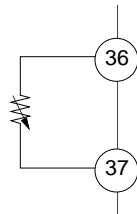

5) RSSI (receiving signal strength indicator)

RSSI detects the input signal level.

The IC generates a DC voltage output, which is nearly proportional to the logarithmic value of RF input level. The output level can be varied by adjusting GADJ (Pin 8) resistance value. Adjust the resistance value so that saturation does not occur when the input level is high.

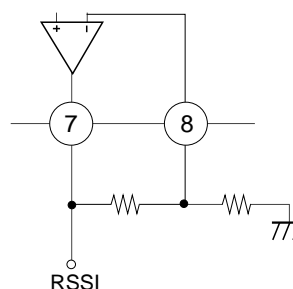
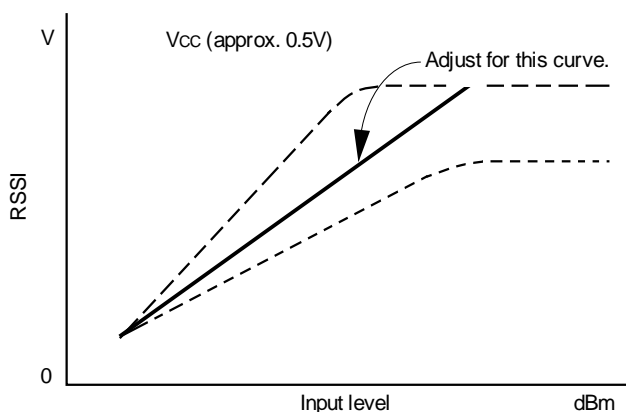

Notes on Operation

1. This IC must be handled with care because it is extremely susceptible to electrostatic surges. Particularly, IFIN (Pin 22) is easily damaged by electrostatic surges.
2. When the 0.1 μ F capacitor connected to Pin 14 has a capacitance of 0.047 μ F or less, the IC malfunctions. Be sure that the employed capacitor has an excellent temperature characteristics.
3. When the capacitance value of the 0.1 μ F capacitor connected to Pin 38 is decreased, the IC characteristics begin to slightly deteriorate. Further, a capacitance value increase would not improve the IC characteristics accordingly.
4. When the capacitance value of the 0.1 μ F capacitor connected to Pin 40 is decreased, the IC characteristics slightly deteriorate.
5. Vcc1 (Pin 33) supplies the power to the reference bias voltage generator circuit which is necessary for IC operations. If the same Vcc power supply is not provided for Vcc voltages to be applied to Pins 11, 19, 24, and 33, ensure that the Pin 33 Vcc rises first.
6. Be sure that nothing is connected to Pins 13, 15, 30, 31, 32, and 35.
7. Resistance between Pins 36 and 37
The signal of 45 MHz, -50 dBm is input from Pin 22 (IFIN) and the level of Pin 3 (BPFOUT) is read. After that when this frequency is varied to +18 kHz and -18 kHz respectively, resistance value between Pins 36 and 37 is varied to be the same attenuation level.
8. Inductance between Pins 26 and 27
Adjustment must be made so that a 45 MHz parallel resonance circuit is formed by the inductor between Pins 26 and 27 and the IC stray capacitor. This adjustment assures that an increased mixer conversion gain is provided at a low input signal level.
Once the optimum value is obtained upon PCB conductive pattern determination, readjustment is unnecessary after sample changes.
9. Pin 19 resonance circuit
Tune this circuit to the crystal oscillation frequency for normal use, tune to the external SG signal frequency when a signal is input from the external SG. Once the optimum value is obtained upon PCB conductive pattern determination, readjustment is unnecessary after sample changes.

Example of Representative Characteristics

The following characteristic curves are measured after IC adjustment. If the IC is not properly adjusted, the resulting characteristics are not close to the representative characteristics presented below. When making measurements, observe precautions 7, 8, and 9 under "Notes on Operation".

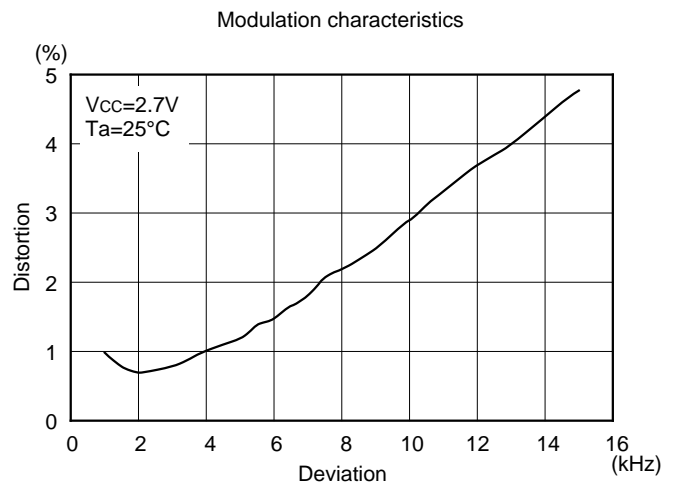
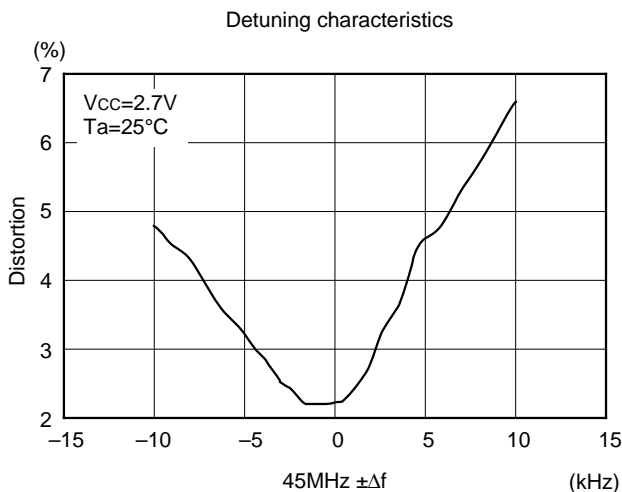
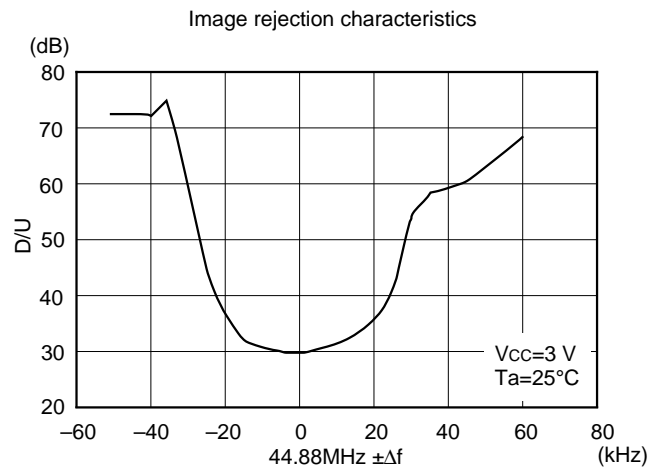
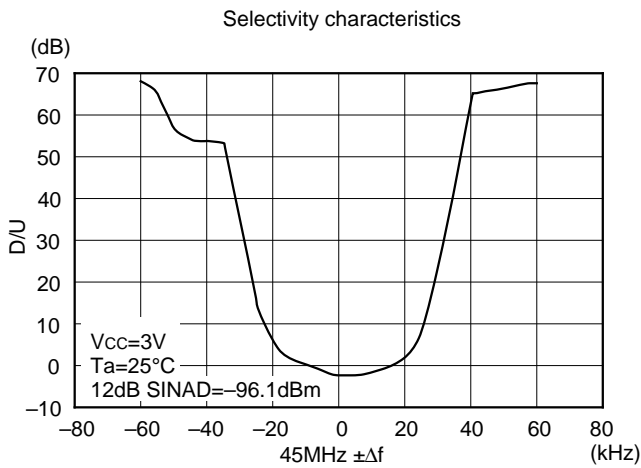
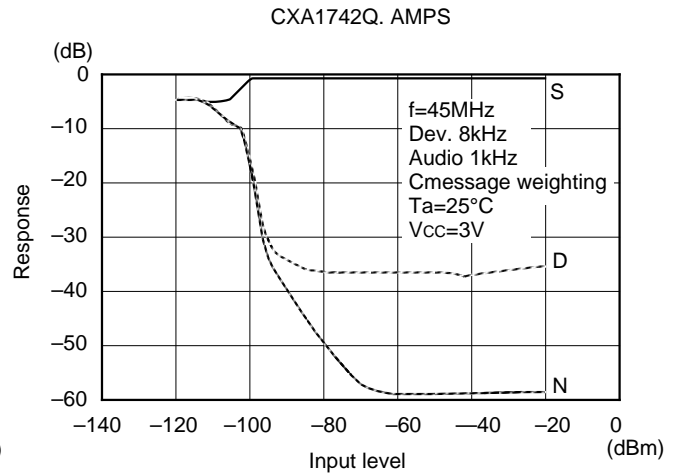
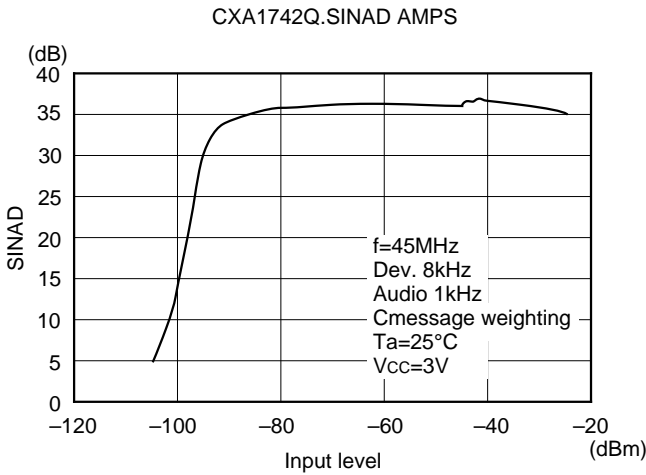

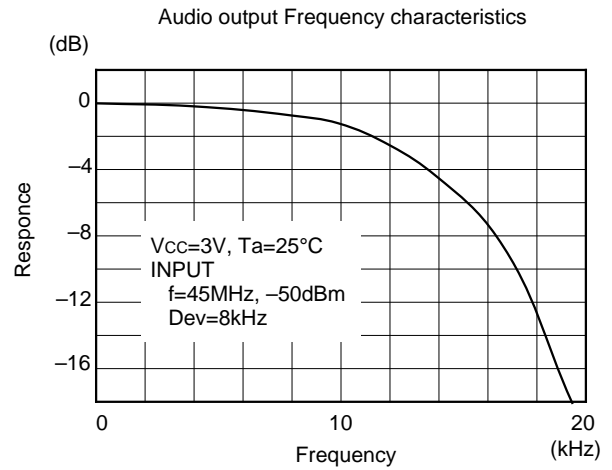
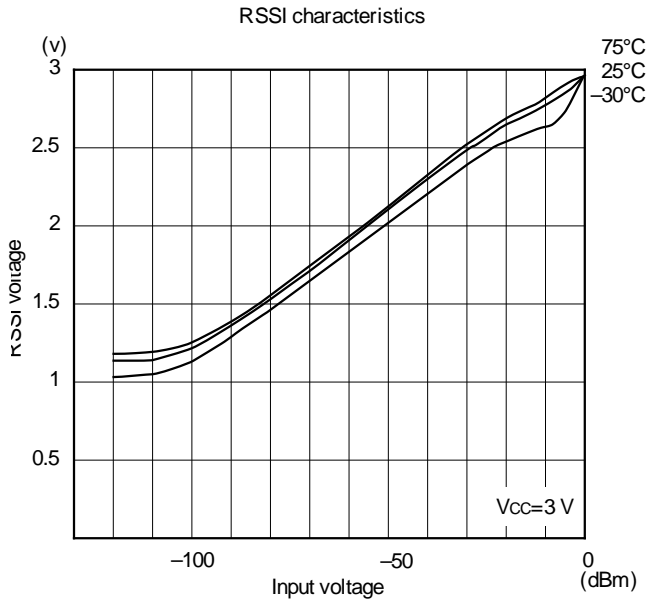

Band-pass filter characteristics

The response characteristics of the band-pass filter (total value of BPF0 and BPF1) are shown below.

Supply voltage Vcc = 3 V, operating temperature Ta = 25°C

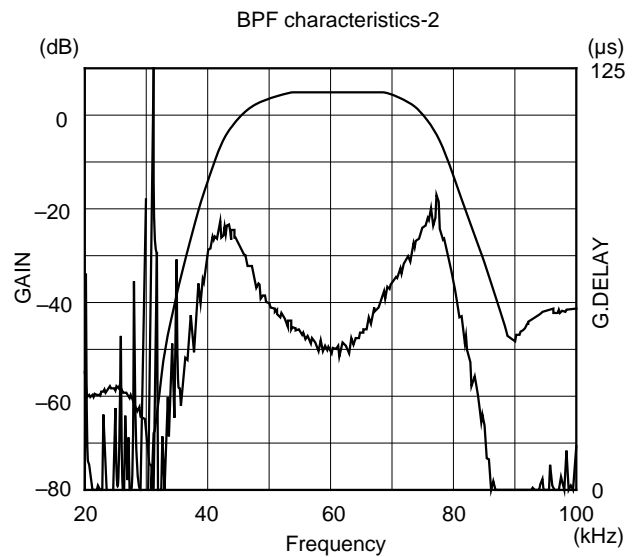
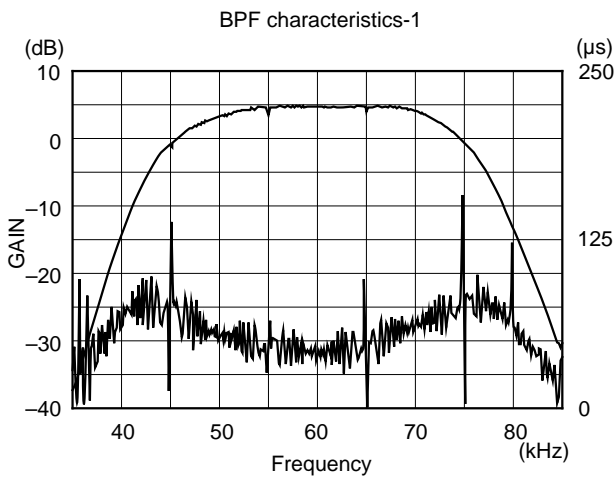
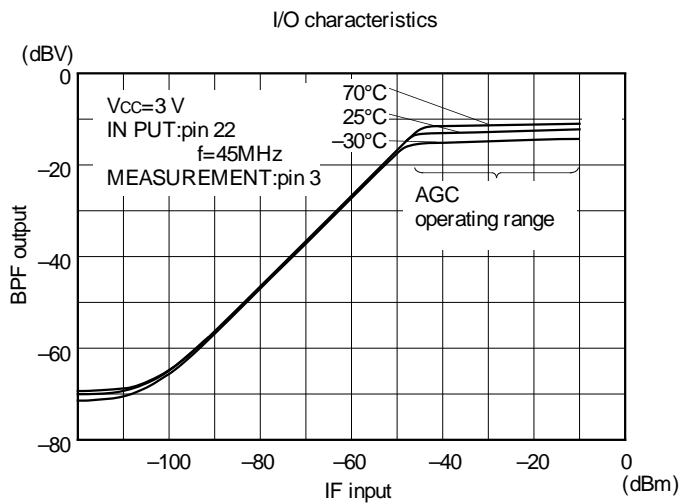

Package Outline Unit : mm

40PIN QFP (PLASTIC)

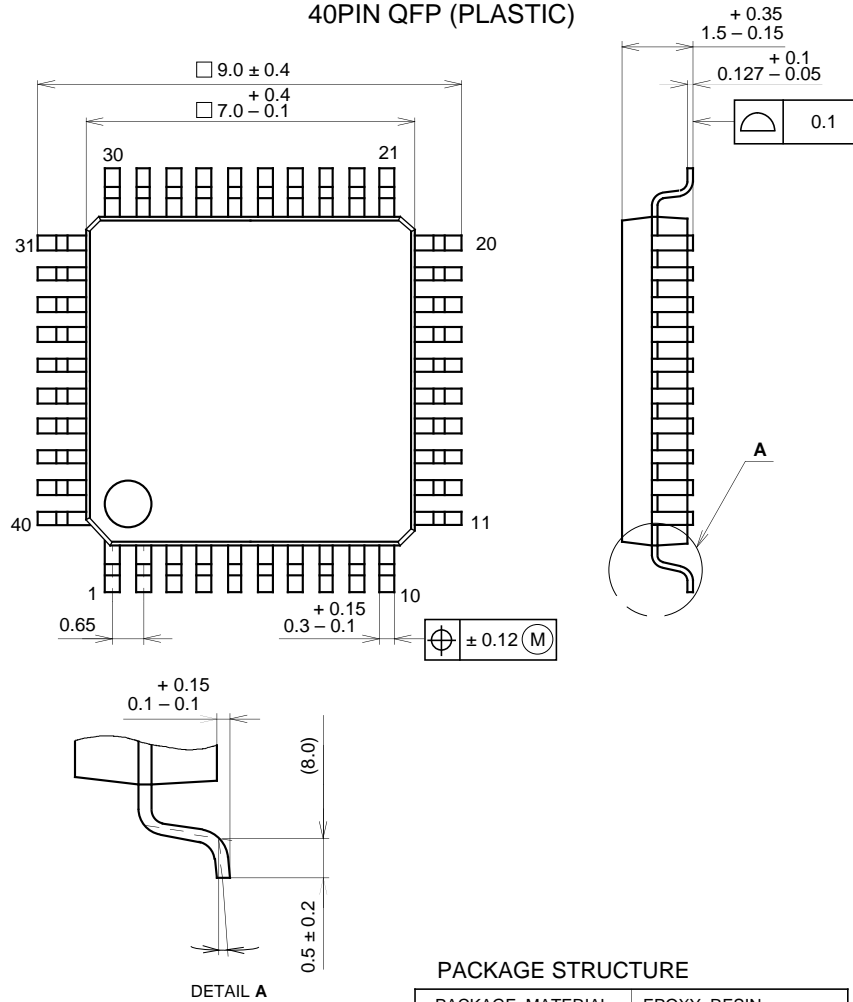

SONY CODE	QFP-40P-L01
EIAJ CODE	*QFP040-P-0707
JEDEC CODE	—

PACKAGE STRUCTURE

PACKAGE MATERIAL	EPOXY RESIN
LEAD TREATMENT	SOLDER / PALLADIUM PLATING
LEAD MATERIAL	COPPER / 42 ALLOY
PACKAGE WEIGHT	0.2g



LittleDiode supplies new, hard to find or obsolete electronic components and semiconductors all over the world.

With over two million different components listed you are sure to find the part you need.

Feel free to visit us today at our online store:

LittleDiode.com

Looking forward to providing you with the best possible service.