

CXA1726AM/AS

Multiplier IC for Displays

Description

The CXA1726AM/AS is a multiplier IC which is used for dynamic convergence, dynamic focus and others in CRT display monitors and projectors. It is used in conjunction with an IC (CXA1470AM/AS) which generates waveforms for deflection compensation.

Features

- Analog multiplier 4ch
- Maximum input voltage $\pm 1.3V$
- Maximum output voltage $\pm 2.7V$ ($R_L = 3.9k\Omega$)
- Frequency response 1.0MHz (-3dB)
- 4 inputs, 1 output 2ch
- 2 inputs, 1 output 2ch
- Operational amplifier 2ch
- Maximum output voltage $\pm 3.65V$ ($R_L = 1k\Omega$)
- Frequency response 1MHz (-3dB)
- Analog switch 1ch
- Maximum output voltage
- Frequency response

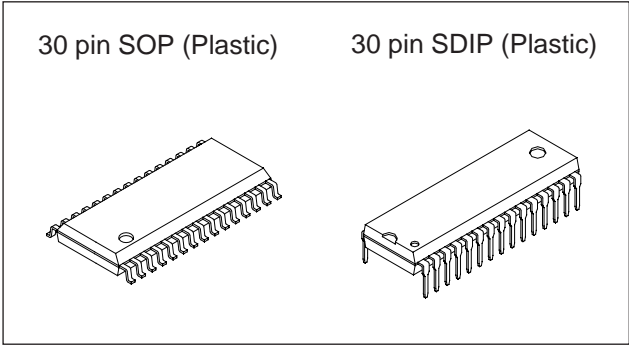

Applications

- CRT display monitors
- Projectors

Structure

Bipolar silicon monolithic IC

Operating Condition

Supply voltage	V _{CC}	5 ± 0.25	V
	V _{EE}	-5 ± 0.25	V

Absolute Maximum Ratings

- Supply voltage V_{CC} 7 V
- V_{EE} -7 V
- Operating temperature T_{opr} -20 to +75 °C
- Storage temperature T_{stg} -65 to +150 °C
- Allowable power dissipation P_D (CXA1726AM) 625 mW
- (CXA1726AS) 1350 mW

Block Diagram and Pin Configuration (Top View)

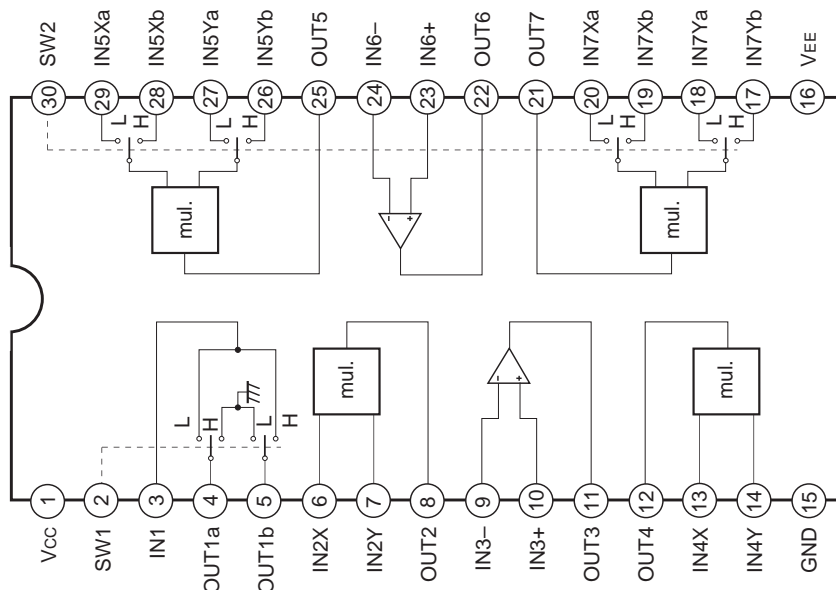

Sony reserves the right to change products and specifications without prior notice. This information does not convey any license by any implication or otherwise under any patents or other right. Application circuits shown, if any, are typical examples illustrating the operation of the devices. Sony cannot assume responsibility for any problems arising out of the use of these circuits.

Pin Description

Pin No.	Symbol	Pin voltage	Equivalent circuit	Description
1	Vcc	5V		Positive supply voltage pin.
2	SW1			Control pin of switch unit. The signal input from IN1 is selected for "a" side or "b" side by the SW1 applied voltage. When SW1 is 2V or less, low turns to "a" side; it is 2.6V or more, high turns to "b" side.
3	IN1	0V		Input pin of switch unit.
4 5	OUT1 a OUT1 b			Output pins of switch unit. The pin which is not selected is GND.
6 13	IN2 X IN4 X	0V 0V		Multiplier IN X input pins.

Pin No.	Symbol	Pin voltage	Equivalent circuit	Description
7 14	IN2 Y IN4 Y	0V 0V		Multiplier IN Y input pins.
8 12 21 25	OUT2 OUT4 OUT7 OUT5	0V 0V 0V 0V		Multiplier output pins.
9 24 10 23	IN3- IN6- IN3+ IN6+			Operational amplifier input pins.
11 22	OUT3 OUT6			Operational amplifier output pins.
15	GND	0V		GND
16	V _{EE}	-5V		Negative supply voltage pin.

Pin No.	Symbol	Pin voltage	Equivalent circuit	Description
18 20 27 29 17 19 26 28	IN7 Ya IN7 Xa IN5 Ya IN5 Xa IN7 Yb IN7 Xb IN5 Yb IN5 Xb	0V		Input pins of multiplier with switch.
30	SW2			Switch pin to select "a" side or "b" side of multiplier with switch. "a" side $\leq 2.0V$ "b" side $\geq 2.6V$

Electrical Characteristics

Multiplier

No.	Item	Symbol	Conditions	Measurement point	Min.	Typ.	Max.	Unit
1	Output offset voltage	V_o	$X = Y = 0V$	OUT	-110	16	110	mV
2	Scale factor	SF	$X = Y = 1V \rightarrow V_1$ $X = -Y = 1V \rightarrow V_2$ $(V_1 + V_2)/2 = SF$		0.95	1	1.05	—
3	Frequency response	G_T	$X = 1V, Y = SG1$		-3	-0.5	1	dB
4	Input dynamic range	V_{IN}					± 2.3	V
5	Output dynamic range	V_{OUT}					± 2.7	V
6	Input bias current	I_{IB}	$X = Y = 1V$	X, Y	-3		3	μA
7	Delay time	D_T	$X = 1V, Y = SG2$ Measure "t".	Y, OUT	50	125	200	ns

Operational Amplifier

No.	Item	Symbol	Conditions	Measurement point	Min.	Typ.	Max.	Unit
8	Input bias current	I _B	IN = 0V	IN	-1	0.35	1	μA
9	Voltage gain	A _v		OUT	50	80		dB
10	Output dynamic range	V _{OUT}					±3.65	V
11	Frequency response	G _T	Inversed input pin = SG1 Non-inversed input pin = GND		-3	-0.15	1.4	dB
12	Input offset voltage	V _I	IN = 0V	↓	-6	-2	+6	mV

Switch

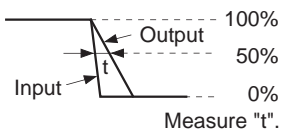
No.	Item	Symbol	Conditions	Measurement point	Min.	Typ.	Max.	Unit
13	Frequency response	G _T	IN = SG1	OUT	-3	-0.15	1	dB
14	Switch threshold high	V _{SH}		SW	2.5			V
15	Switch threshold low	V _{SL}		SW			2.0	V
16	Output dynamic range	V _{OUT}		OUT			±3.1	V
17	Input bias current	I _B	IN = 0V	IN	-1	-0.4	1	μA
18	Output offset voltage	V _O	IN = 0V	OUT	-15	-3	15	mV
19	Delay time	D _T	X = 1V, Y = SG2 	IN, OUT	50	113	200	ns

No.	Item	Symbol	Conditions	Measurement point	Min.	Typ.	Max.	Unit
20	Current consumption 1	I _{CC}		A1	21	26	33	mA
21	Current consumption 2	I _{EE}		A16	-33	-26	-21	mA

Electrical Characteristics Measurement Circuit

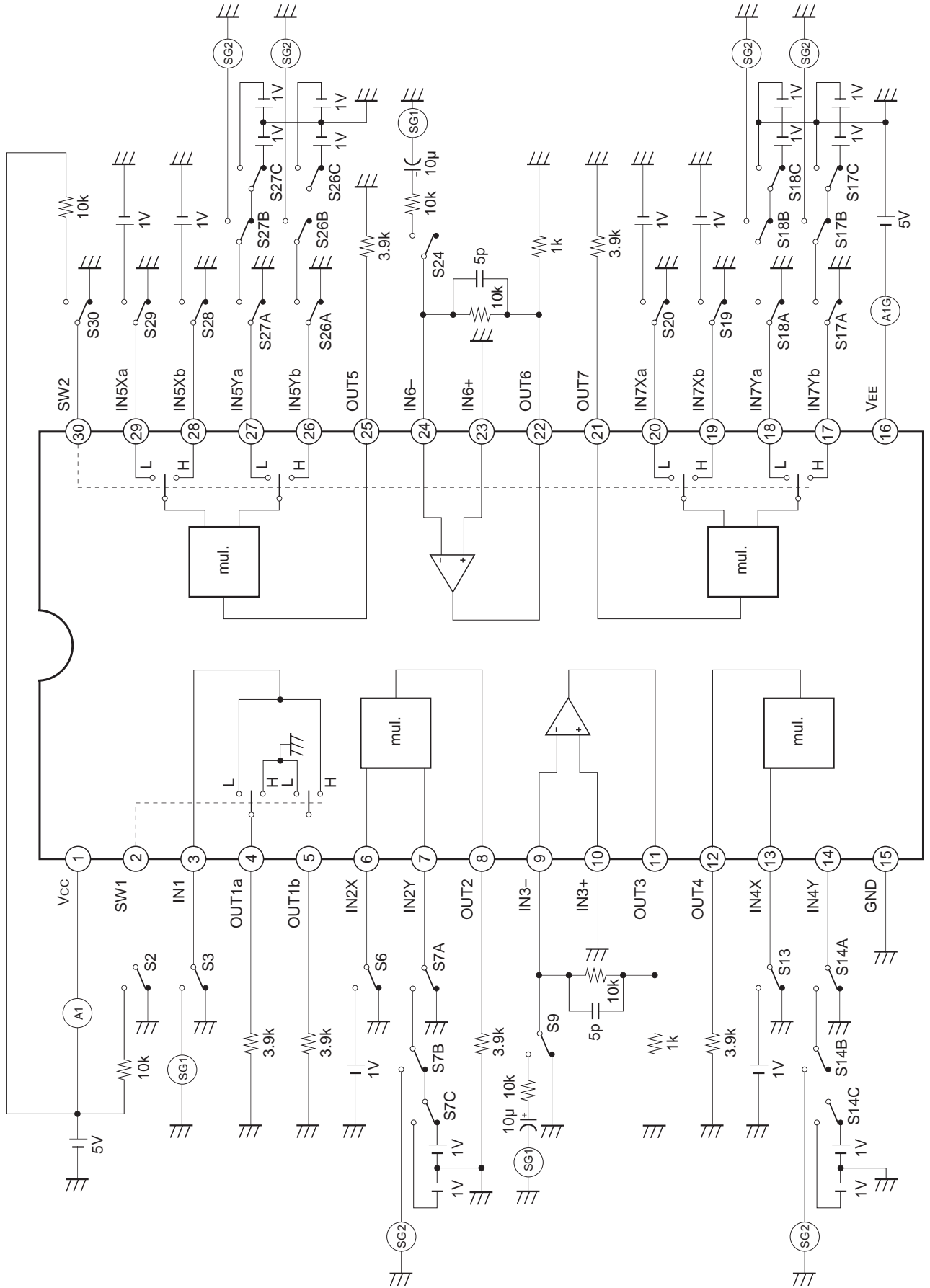

Application Circuit

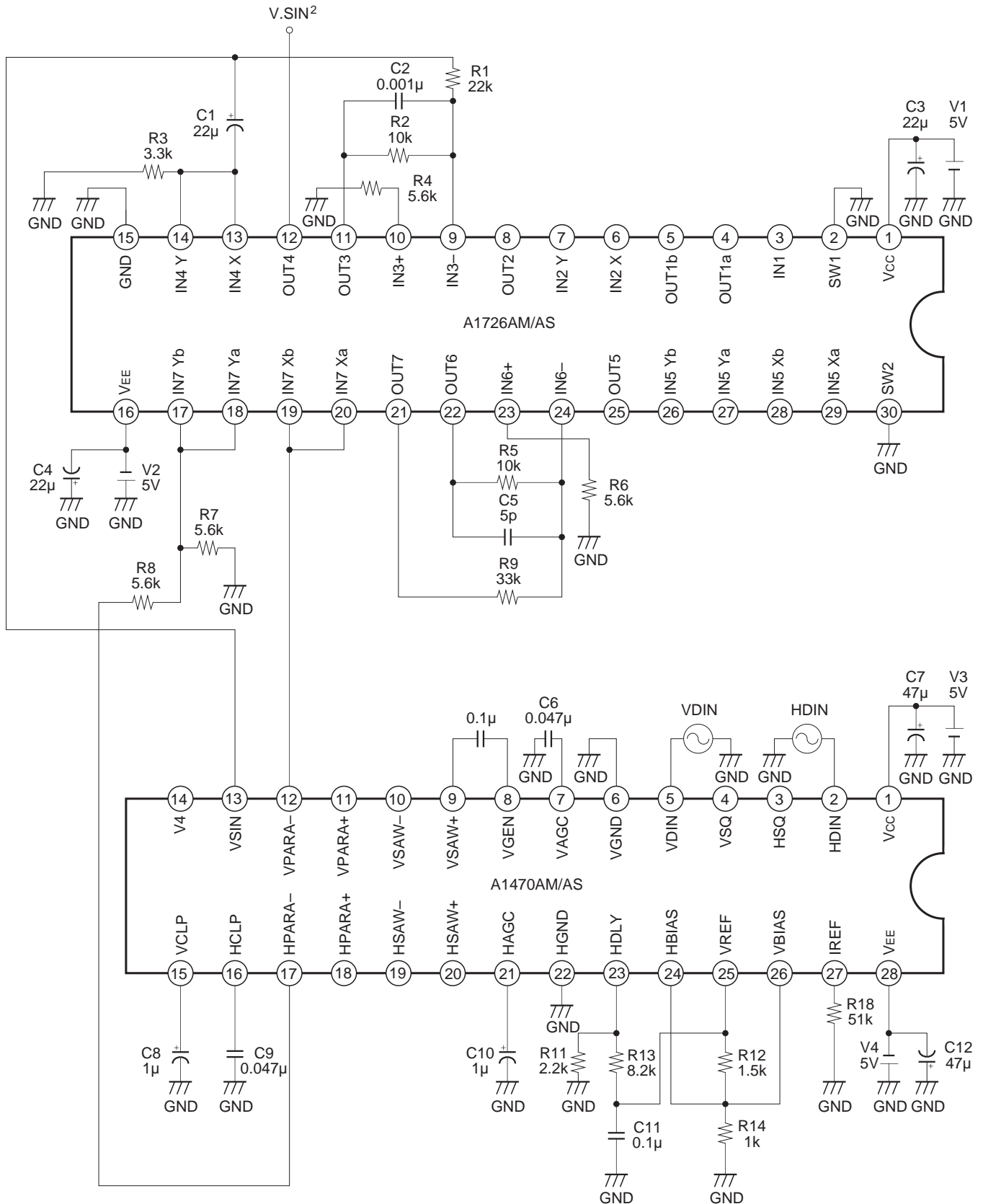

Application circuits shown are typical examples illustrating the operation of the devices. Sony cannot assume responsibility for any problems arising out of the use of these circuits or for any infringement of third party patent and other right due to same.

Input Signals

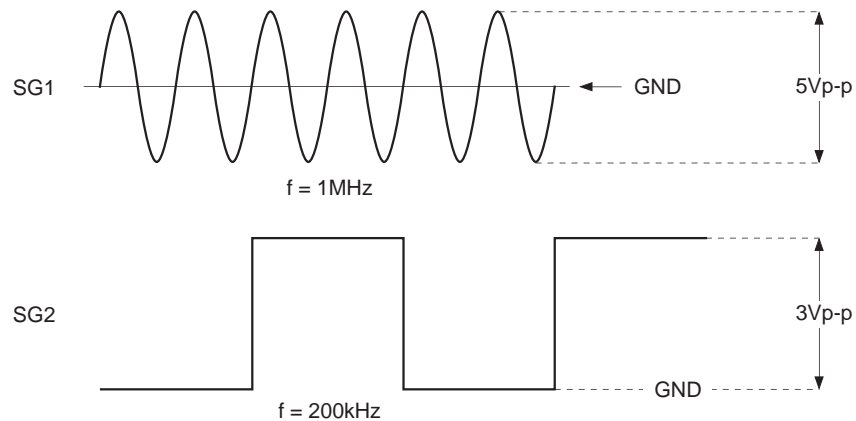

Description of Operation

- Multiplier

The input X and Y signals of the multiplier are multiplied and output to the OUT pins.

- Operational amplifier

This inputs the signals which have been output from the multiplier.

* Care is required with ringing in the operational amplifier. Placing a 5pF capacitor in parallel with the feedback resistor is recommended as a preventive measure.

- Switch

The signal input from IN1 is selected for "a" side or "b" side by the SW1 applied voltage.

When SW1 is 2V or less, low turns to "a" side; it is 2.6V or more, high turns to "b" side.

The unselected output pin is connected to GND.

* For the multipliers with a switch, "a" side or "b" side is selected under the same conditions.

Multiplier frequency response

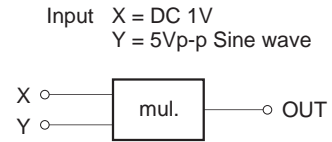
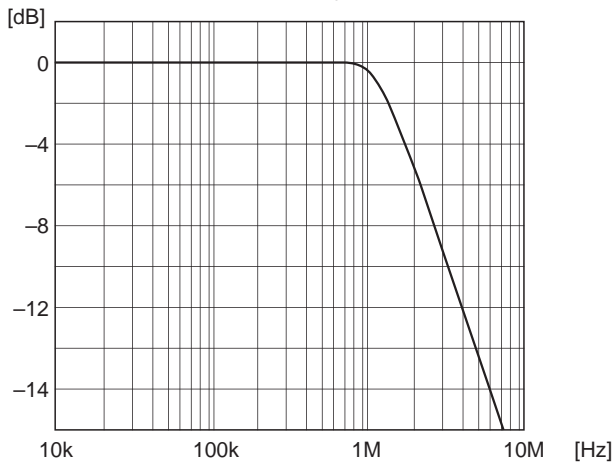

Operational amplifier frequency response

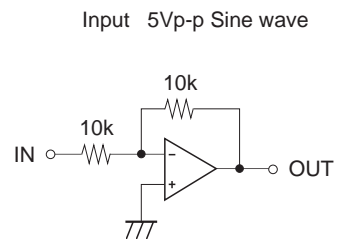
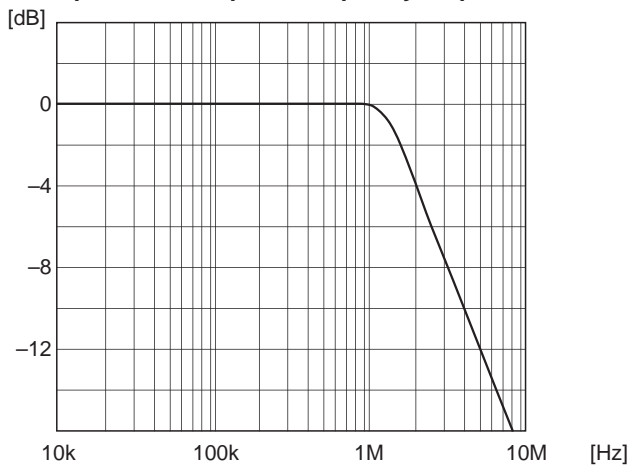

Multiplier gain characteristics

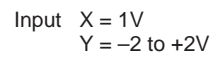
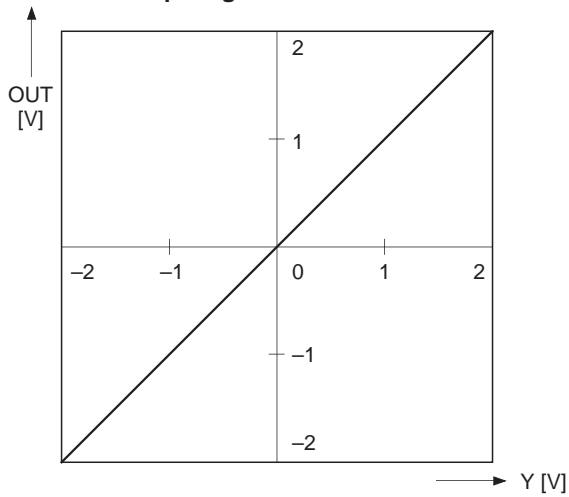

Package Outline Unit: mm

CXA1726AM 30PIN SOP(PLASTIC)

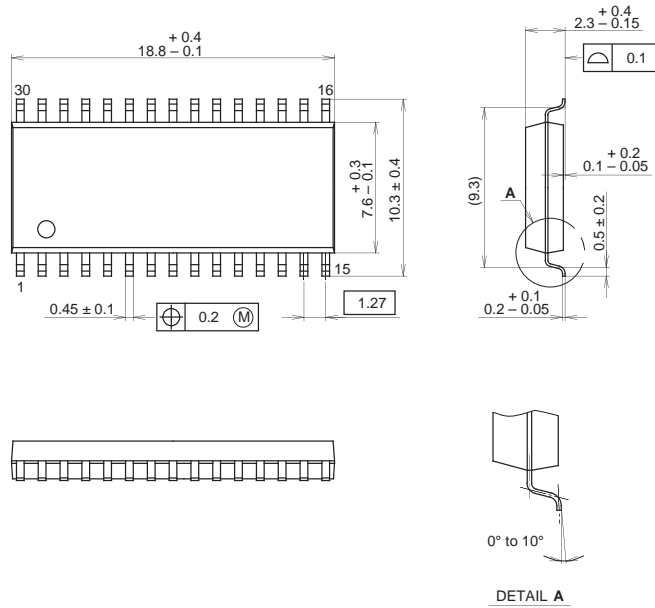

SONY CODE		SOP-30P-L03	
EIAJ CODE	SOP030-P-0375	PACKAGE MATERIAL	EPOXY RESIN
JEDEC CODE	---	LEAD TREATMENT	SOLDER PLATING
		LEAD MATERIAL	COPPER ALLOY
		PACKAGE MASS	0.7g

CXA1726AS 30PIN SDIP (PLASTIC)

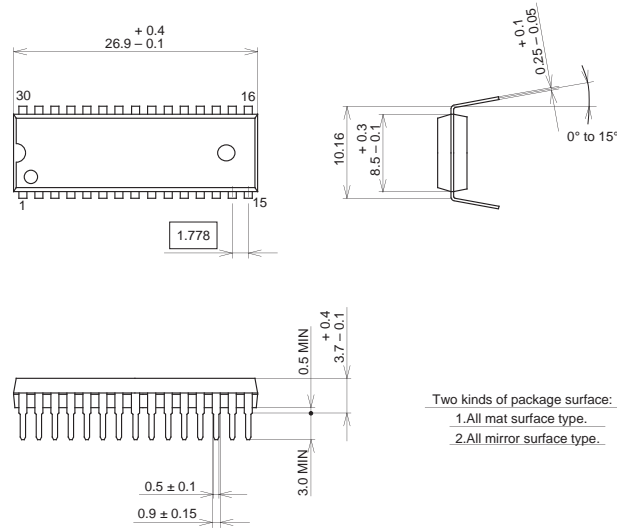

SONY CODE		SDIP-30P-01	
EIAJ CODE	SDIP030-P-0400	MOLDING COMPOUND	EPOXY RESIN
JEDEC CODE	---	LEAD TREATMENT	SOLDER/PALLADIUM PLATING
		LEAD MATERIAL	COPPER ALLOY
		PACKAGE MASS	1.8g

NOTE : PALLADIUM PLATING
 This product uses S-PdPPF (Sony Spec.-Palladium Pre-Plated Lead Frame).

This datasheet has been downloaded from:

www.DatasheetCatalog.com

Datasheets for electronic components.



LittleDiode supplies new, hard to find or obsolete electronic components and semiconductors all over the world.

With over two million different components listed you are sure to find the part you need.

Feel free to visit us today at our online store:

LittleDiode.com

Looking forward to providing you with the best possible service.