

Pre-driver for Ultra-High Resolution Computer Display

Description

The CXA1709P is a bipolar IC designed for use in ultra-high resolution computer displays.

Features

- Built-in super wide-band amplifier (250 MHz/-3dB typ.)
- 1 channel to 1 package
- Contrast can be controlled by DC.
- Rise/fall time of 2ns or less due to output amplitude of 4 VP-P
- Drive adjustment for the three channels (R, G, B) is easily accomplished because the contrast characteristic is linear.

Absolute Maximum Ratings (Ta=25°C)

• Supply voltage	Vcc	14	V
• Operating temperature	Topr	-20 to +75	°C
• Storage temperature	Tstg	-65 to +150	°C
• Allowable power dissipation	Pd	1040	mW

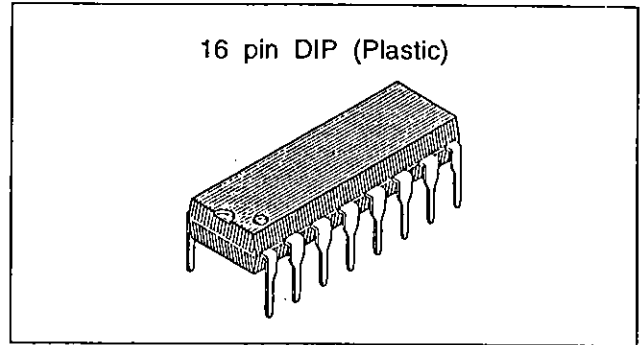

Operating Conditions

• Recommended supply voltage	12.0	V
• Operating range	12 ±0.5	V

Structure

Bipolar silicon monolithic IC

Applications

Pre-driver for ultra-high resolution computer displays

Block Diagram and Pin Configuration

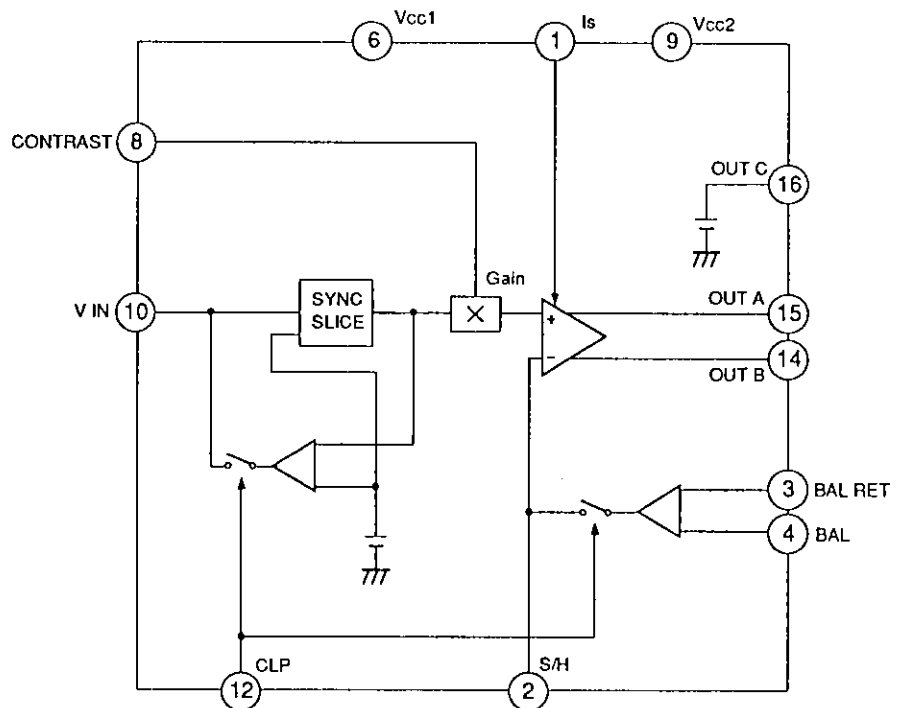
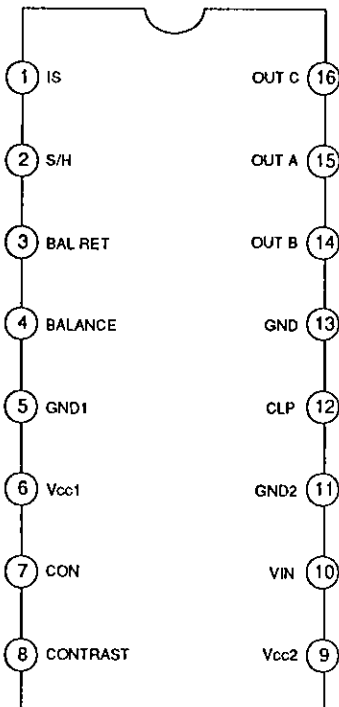

Sony reserves the right to change products and specifications without prior notice. This information does not convey any license by any implication or otherwise under any patents or other right. Application circuits shown, if any, are typical examples illustrating the operation of the devices. Sony cannot assume responsibility for any problems arising out of the use of these circuits.

Pin Description

Pin No.	Symbol	Pin voltage	Equivalent circuit	Description
1	IS	3V		Determines a reference current source. Connect a 15 kΩ metal film resistor between Pin 1 and GND.
2	S/H	8V		Connect a capacitor for clamp.
3	BAL RET	4V		Inputs a feedback signal from the drive stage to stabilize the DC bias at cathode drive stage.
4	BALANCE	4V		Sets a output DC level.
8	CONTRAST	—		Contrast control. Control is possible between 0 to 5 V DC.
10	VIN			Video signal input.
12	CLP	—		Clamp pulse input.

Pin No.	Symbol	Pin voltage	Equivalent circuit	Description
14	OUT B			Negative polarity output signal.
15	OUT A			Positive polarity output signal.
16	OUT C	2.6V		2.6V power supply output.
6	Vcc1	12V		Supply voltage for control system.
9	Vcc2	12V		Supply voltage for pre-amplifier block.
5	GND1	0		GND for control system.
11	GND2	0		GND for pre-amplifier block.
7	CON	0		Connect to GND.

Electrical Characteristics Measurement Circuit

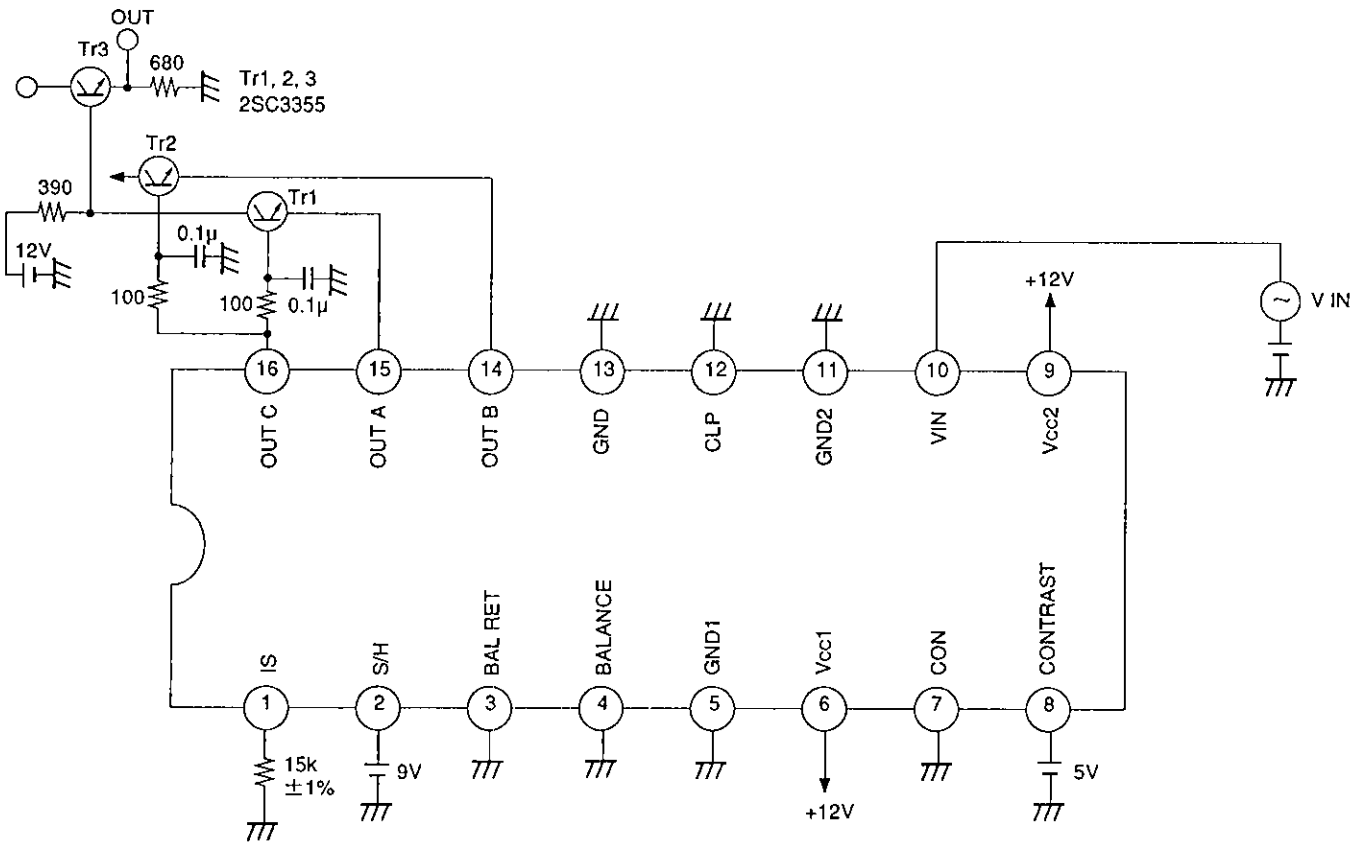

Electrical Characteristics

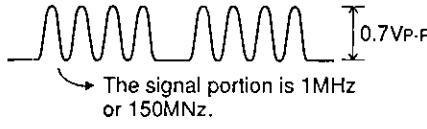
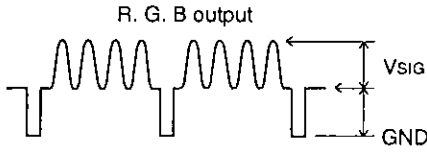
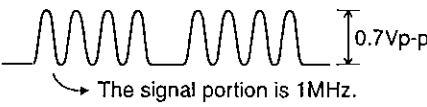
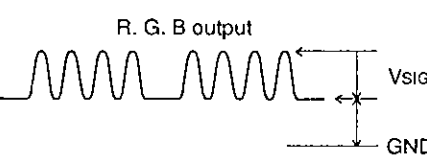
No.	Item	Symbol	Input conditions and measurements	Min.	Typ.	Max.	Unit
1	Supply current	I <sub>CC</sub>	Measure the inflow current at Pins 6 and 9 at no signal, no load.		33	45	mA
2	Frequency response	f <sub>150MHz</sub>	<p>R. G. B input</p>  <p>R. G. B output</p>  <p>Input: Input 0.7 VP-P, 1 MHz or 150 MHz and measure the output amplitude V<sub>SIG</sub>. Specifications can be obtained through the following formula, assuming V<sub>SIG1</sub> for 1MHz and V<sub>SIG150</sub> for 150MHz.</p> $f_{1-150} = 20 \log \left( \frac{V_{SIG150}}{V_{SIG1}} \right) \text{ (dB)}$ <p>* Measure V<sub>SIG</sub> peak to peak.</p>	- 3.0	+ 1.0	—	dB
3	Contrast control	CONT <sub>MAX</sub>	<p>R. G. B input</p>  <p>R. G. B output</p>  <p>Input: Measure the output amplitude V<sub>SIG</sub> at 0.7 VP-P, 1 MHz. The specifications can be obtained though the following formula.</p> $CONT_{MAX (MIN)} = 20 \log \left( \frac{V_{SIG}}{0.7} \right) \text{ (dB)}$	13.5	15.0	—	dB

Application Circuit

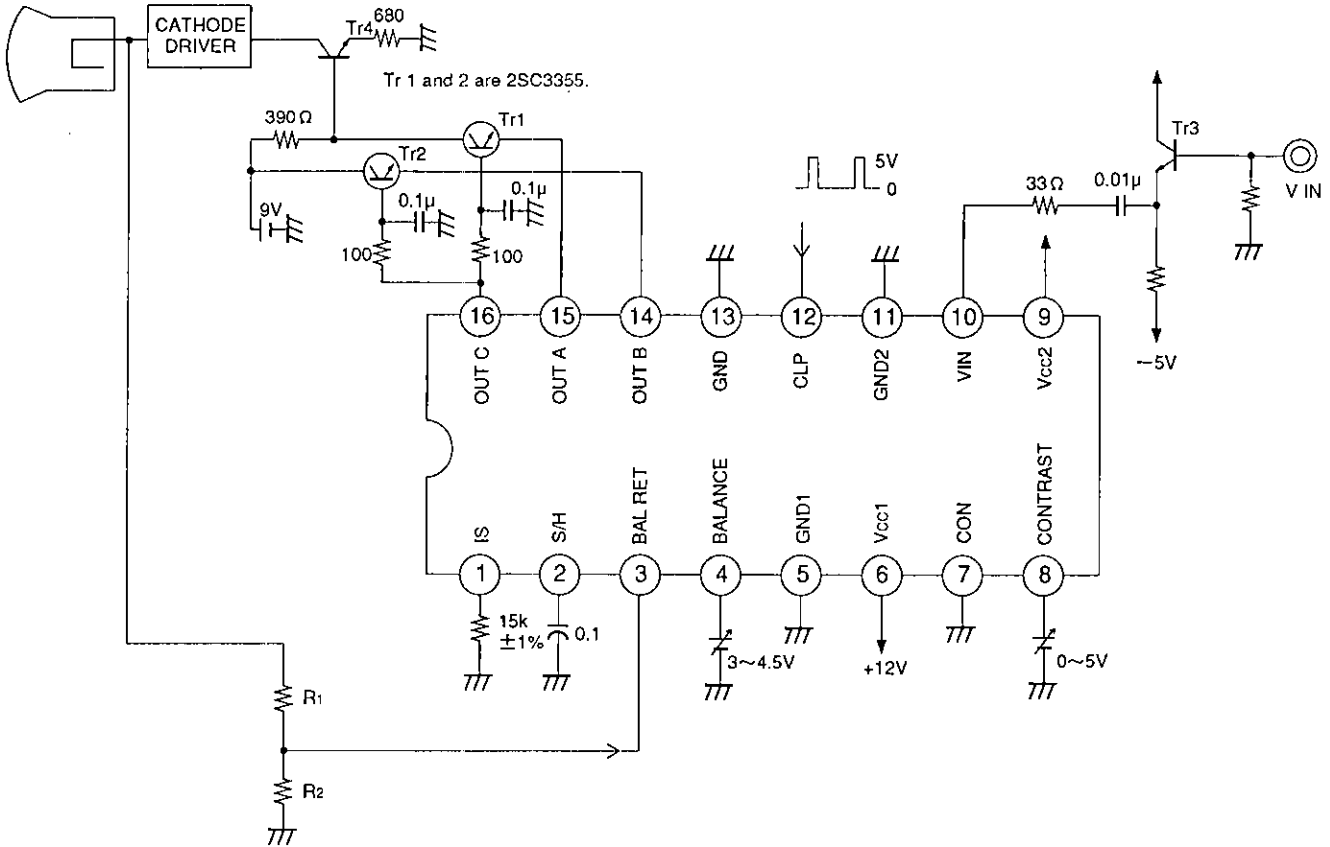

Application circuits shown are typical examples illustrating the operation of the devices. Sony cannot assume responsibility for any problems arising out of the use of these circuits or for any infringement of third party and other right due to same.

Input/Output Pulse Waveforms and Description of Operation

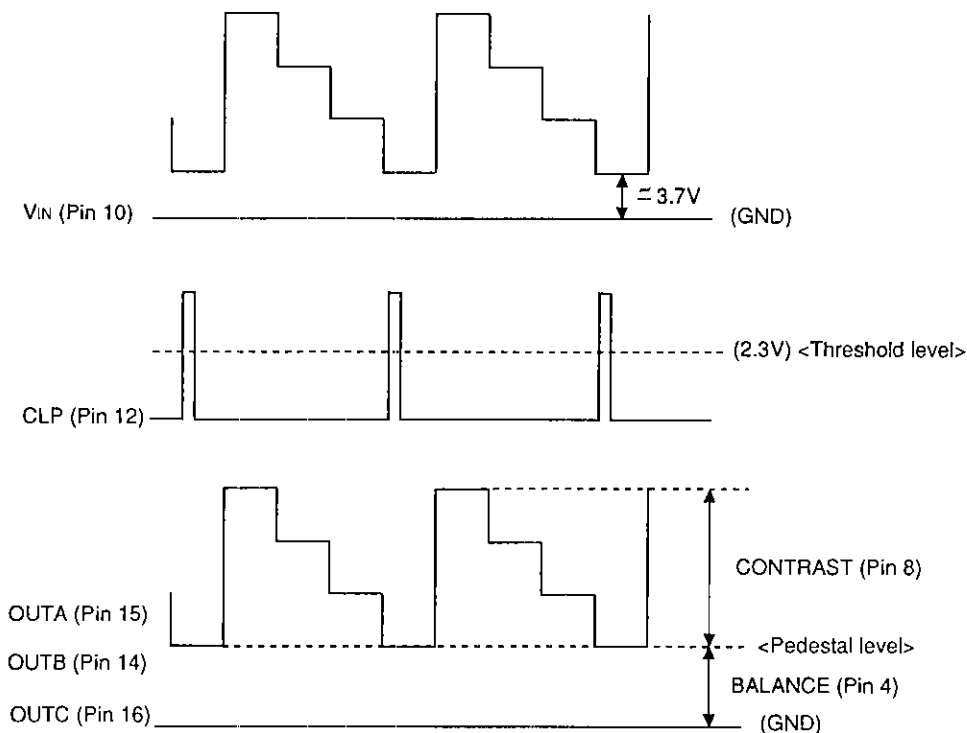

1. Contrast

Gain is controlled on the VIN (Pin 10) input signal, using the DC voltage input from CONTRAST (Pin 8). The control range is from -20 to 15 dB (typ.).

2. Pedestal Clamp

The pedestal level is clamped while CLAMP (Pin 12) is high. The threshold level of the clamp pulse is approximately 2.3 V. Note that 300 ns are required for clamp time.

The output DC level can be varied by the DC input from BALANCE (Pin 4). In this time, the emitter follower output at the external transistor should not be below 2 V or low.

3. The output signal is amplified by the external power amplifier and drives the CRT. The amplified signal voltage is fed back to Pin 3. Then, set the R1 and R2 values so that the pedestal level at Pin 3 is  $4 \pm 0.5$  V.

Frequency response

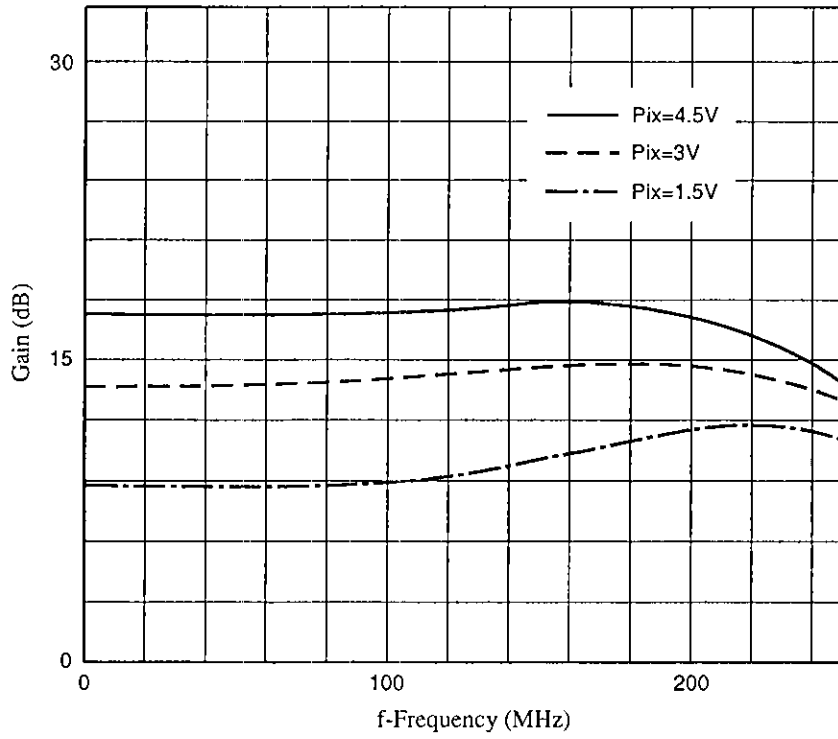

Gain control characteristics

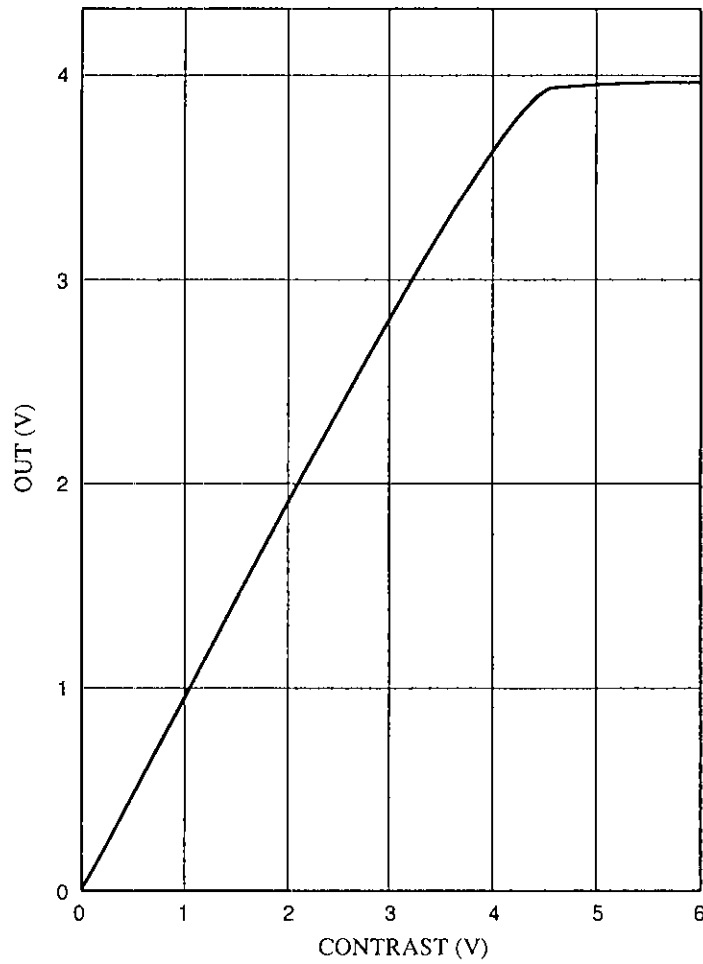

Package Outline Unit : mm

16pin DIP (Plastic) 300mil 1.0g

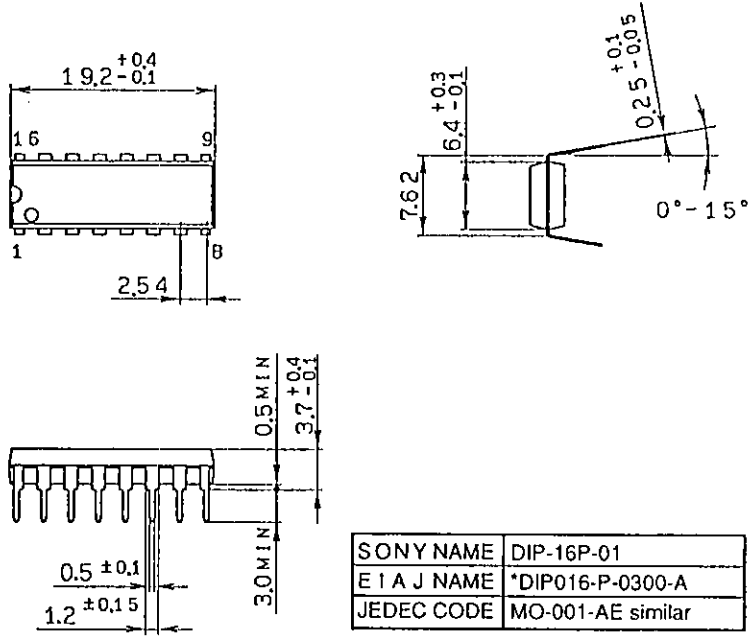



LittleDiode supplies new, hard to find or obsolete electronic components and semiconductors all over the world.

With over two million different components listed you are sure to find the part you need.

Feel free to visit us today at our online store:

[LittleDiode.com](http://LittleDiode.com)

Looking forward to providing you with the best possible service.