

## All Band TV Tuner IC (VHF-CATV-UHF)

### Description

The CXA1695L is a single chip TV tuner IC which performs as an oscillator, mixer for VHF/CATV and UHF bands. An IF amplifier is also provided.

This IC achieves a large reduction of external parts in addition to miniaturizing the tuner and increasing manufacturing productivity, reliability and design efficiency.

This IC is pin-compatible with the CXA1594L with improvement in noise figure and oscillation stability.

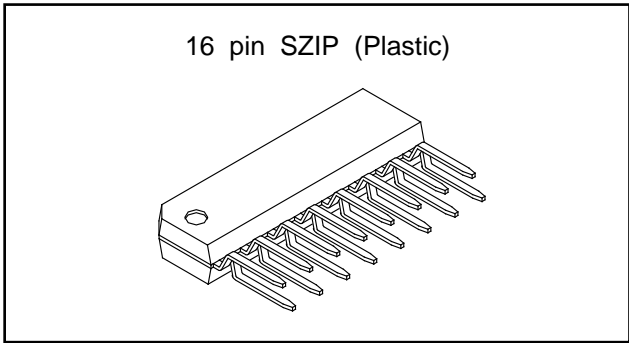

### Features

- On-chip oscillator and mixer for UHF band
- Low noise figure
- Reduced spurious interference
- Superior cross modulation
- Stable oscillation characteristics
- Ultra small package ensures tuner miniaturization

### Applications

- CTV tuner
- CATV UP-DOWN converter

### Structure

Bipolar silicon monolithic IC

### Absolute Maximum Ratings (Ta=25 °C)

|                               |                  |             |    |
|-------------------------------|------------------|-------------|----|
| • Supply voltage              | V <sub>CC</sub>  | 11          | V  |
| • Storage temperature         | T <sub>stg</sub> | -55 to +150 | °C |
| • Allowable power dissipation | P <sub>D</sub>   | 930         | mW |
| (when mounted on board)       |                  |             |    |

### Operating Conditions

|                         |                  |            |    |
|-------------------------|------------------|------------|----|
| • Supply voltage        | V <sub>CC</sub>  | 8.1 to 9.9 | V  |
| • Operating temperature | T <sub>opr</sub> | -20 to +75 | °C |

### Block Diagram and Pin Configuration

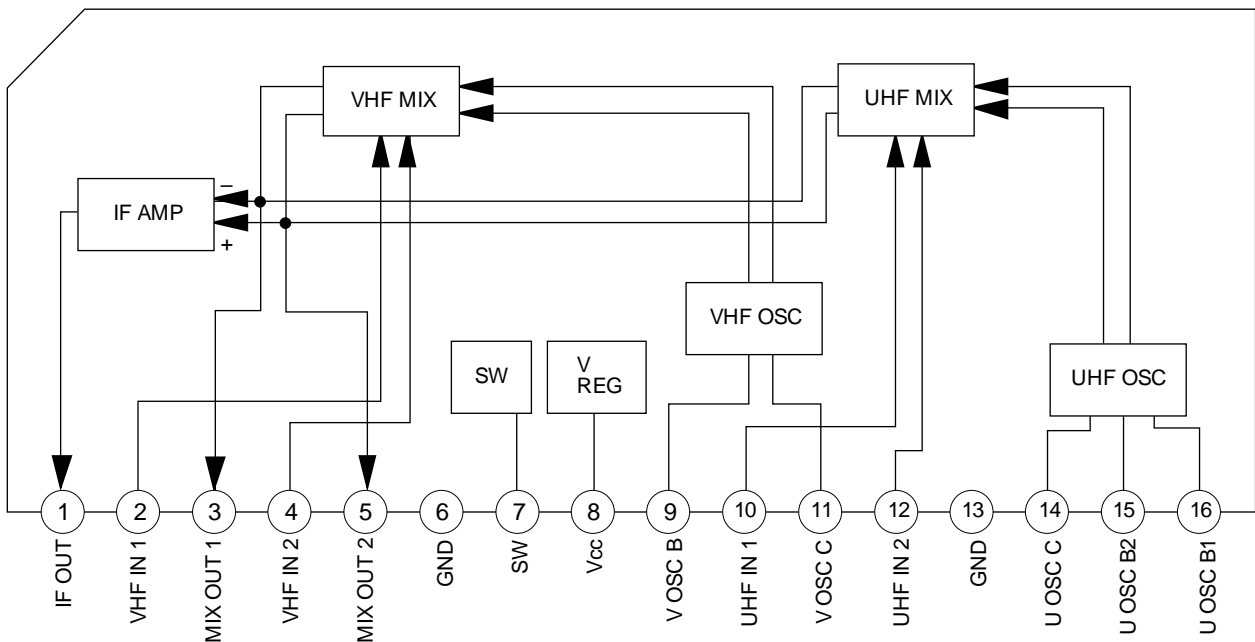

Sony reserves the right to change products and specifications without prior notice. This information does not convey any license by any implication or otherwise under any patents or other right. Application circuits shown, if any, are typical examples illustrating the operation of the devices. Sony cannot assume responsibility for any problems arising out of the use of these circuits.

**Pin Description and Equivalent Circuit**

| Pin No. | Symbol    | Typical pin voltage (V)    | Equivalent circuit | Description   |
|---------|-----------|----------------------------|--------------------|---|
| 1       | IF OUT    | Under VHF operation<br>4.4 |                    | IF output.  |
|         |           | Under UHF operation<br>4.4 |                    |   |
| 2       | VHF IN 1  | 3.2                        |                    | VHF input.<br>Normally a decoupling capacitor is connected at pin 2 to GND and pin 4 is used for input.             |
|         |           | 3.3                        |                    |   |
| 4       | VHF IN 2  | 3.2                        |                    |   |
|         |           | 3.3                        |                    |   |
| 3       | MIX OUT 1 | 7.5                        |                    | Mixer output and IF amplifier input.  |
|         |           | 7.2                        |                    |   |
| 5       | MIX OUT 2 | 7.5                        |                    |   |
|         |           | 7.2                        |                    |   |
| 6       | GND       | 0                          |                    | GND   |
| 7       | SW        | 3V or more                 |                    | UHF/VHF switch pin.<br>Connect 9V source through about a 10kΩ resistor for VHF reception; 0V or leave open for UHF. |
|         |           | 0.4V or less               |                    |   |

| Pin No. | Symbol   | Typical pin voltage (V) | Equivalent circuit | Description   |
|---------|----------|-------------------------|--------------------|---|
| 8       | Vcc      | 9.0                     |                    | Power supply  |
| 9       | V OSC B  | 3.5                     |                    | VHF oscillator.   |
|         |          | 3.7                     |                    |   |
| 11      | V OSC C  | 6.7                     |                    | VHF oscillator.   |
|         |          | 9.0                     |                    |   |
| 10      | UHF IN 1 | 3.3                     |                    | UHF input.<br>The balanced input to Pins 10 and 12, or a decoupling capacitor is connected at Pin 12 to GND and Pin 10 is used for input. |
|         |          | 3.1                     |                    |   |
| 12      | UHF IN 2 | 3.3                     |                    | UHF input.<br>The balanced input to Pins 10 and 12, or a decoupling capacitor is connected at Pin 12 to GND and Pin 10 is used for input. |
|         |          | 3.1                     |                    |   |
| 13      | GND      | 0                       |                    | GND   |
| 14      | U OSC C  | 9.0                     |                    | UHF oscillator.   |
|         |          | 6.5                     |                    |   |
| 15      | U OSC B2 | 3.6                     |                    | UHF oscillator.   |
|         |          | 3.4                     |                    |   |
| 16      | U OSC B1 | 3.6                     |                    | UHF oscillator.   |
|         |          | 3.4                     |                    |   |

## Electrical Characteristics

See Electrical Characteristics Test Circuit ( $T_a=25^{\circ}\text{C}$ ,  $V_{CC}=9\text{V}$ )

| Item                           | Symbol           | Measurement conditions   | Min. | Typ.  | Max.      | Unit     |
|--------------------------------|------------------|--|------|-------|-----------|----------|
| Circuit current                | IccV             | VHF operation, no signal   |      | 45.0  | 58.0      | mA       |
|                                | IccU             | UHF operation, no signal   |      | 45.0  | 58.0      | mA       |
| Conversion gain<br>*1          | CG1              | VHF operation, $f_{RF}=55\text{ MHz}$ , input level $-40\text{ dBm}$                                   | 17.5 | 20.5  | 23.5      | dB       |
|                                | CG2              | VHF operation, $f_{RF}=360\text{ MHz}$ , input level $-40\text{ dBm}$                                  | 18.0 | 21.0  | 24.0      | dB       |
|                                | CG3              | UHF operation, $f_{RF}=360\text{ MHz}$ , input level $-40\text{ dBm}$                                  | 23.0 | 26.0  | 29.0      | dB       |
|                                | CG4              | UHF operation, $f_{RF}=800\text{ MHz}$ , input level $-40\text{ dBm}$                                  | 24.0 | 27.0  | 30.0      | dB       |
| Noise figure<br>*1*2           | NF1              | VHF operation, $f_{RF}=55\text{ MHz}$  |      | 9.5   | 12.5      | dB       |
|                                | NF2              | VHF operation, $f_{RF}=360\text{ MHz}$   |      | 10.0  | 13.0      | dB       |
|                                | NF3              | UHF operation, $f_{RF}=360\text{ MHz}$   |      | 6.0   | 10.0      | dB       |
|                                | NF4              | UHF operation, $f_{RF}=800\text{ MHz}$   |      | 7.0   | 11.0      | dB       |
| 1% cross<br>modulation<br>*1*3 | CM1              | VHF operation, $f_D=55\text{ MHz}$<br>$f_{UD}=\pm 12\text{ MHz}$                                       | 95.0 | 99.0  |           | dB $\mu$ |
|                                | CM2              | VHF operation, $f_D=360\text{ MHz}$<br>$f_{UD}=\pm 12\text{ MHz}$                                      | 93.0 | 97.0  |           | dB $\mu$ |
|                                | CM3              | UHF operation, $f_D=360\text{ MHz}$<br>$f_{UD}=\pm 12\text{ MHz}$                                      | 86.0 | 90.0  |           | dB $\mu$ |
|                                | CM4              | UHF operation, $f_D=800\text{ MHz}$<br>$f_{UD}=\pm 12\text{ MHz}$                                      | 86.0 | 90.0  |           | dB $\mu$ |
| Max. output<br>power           | Pomax<br>(sat)   | 50 $\Omega$ load   | +8.0 | +12.0 |           | dBm      |
| Switch ON drift                | $\Delta f_{sw1}$ | VHF operation, $f_{osc}=100\text{ MHz}$<br>Frequency drift from 3 s to 3 min. after switch ON          |      |       | $\pm 300$ | kHz      |
|                                | $\Delta f_{sw2}$ | VHF operation, $f_{osc}=405\text{ MHz}$<br>Frequency drift from 3 s to 3 min. after switch ON          |      |       | $\pm 400$ | kHz      |
|                                | $\Delta f_{sw3}$ | UHF operation, $f_{osc}=405\text{ MHz}$<br>Frequency drift from 3 s to 3 min. after switch ON          |      |       | $\pm 600$ | kHz      |
|                                | $\Delta f_{sw4}$ | UHF operation, $f_{osc}=845\text{ MHz}$<br>Frequency drift from 3 s to 3 min. after switch ON          |      |       | $\pm 700$ | kHz      |
| +B supply<br>voltage drift     | $\Delta f_{st1}$ | VHF operation, $f_{osc}=100\text{ MHz}$<br>Frequency shift when $V_{CC} +9\text{ V}$ changes $\pm 5\%$ |      |       | $\pm 200$ | kHz      |
|                                | $\Delta f_{st2}$ | VHF operation, $f_{osc}=405\text{ MHz}$<br>Frequency shift when $V_{CC} +9\text{ V}$ changes $\pm 5\%$ |      |       | $\pm 300$ | kHz      |
|                                | $\Delta f_{st3}$ | UHF operation, $f_{osc}=405\text{ MHz}$<br>Frequency shift when $V_{CC} +9\text{ V}$ changes $\pm 5\%$ |      |       | $\pm 400$ | kHz      |
|                                | $\Delta f_{st4}$ | UHF operation, $f_{osc}=845\text{ MHz}$<br>Frequency shift when $V_{CC} +9\text{ V}$ changes $\pm 5\%$ |      |       | $\pm 400$ | kHz      |

\*1) Measured value for untuned inputs. Unbalanced input for VHF; balanced input for UHF.

\*2) Noise figure is uncorrected for image.

\*3) Desired signal ( $f_D$ ) input level is  $-34\text{ dBm}$ . Undesired signal ( $f_{UD}$ ) is  $100\text{ kHz}$  at  $40\%$  AM. The measurement value is undesired signal level, it measured with spectrum analyzer at  $S/I=46\text{ dB}$ .

Electrical Characteristics Test Circuit

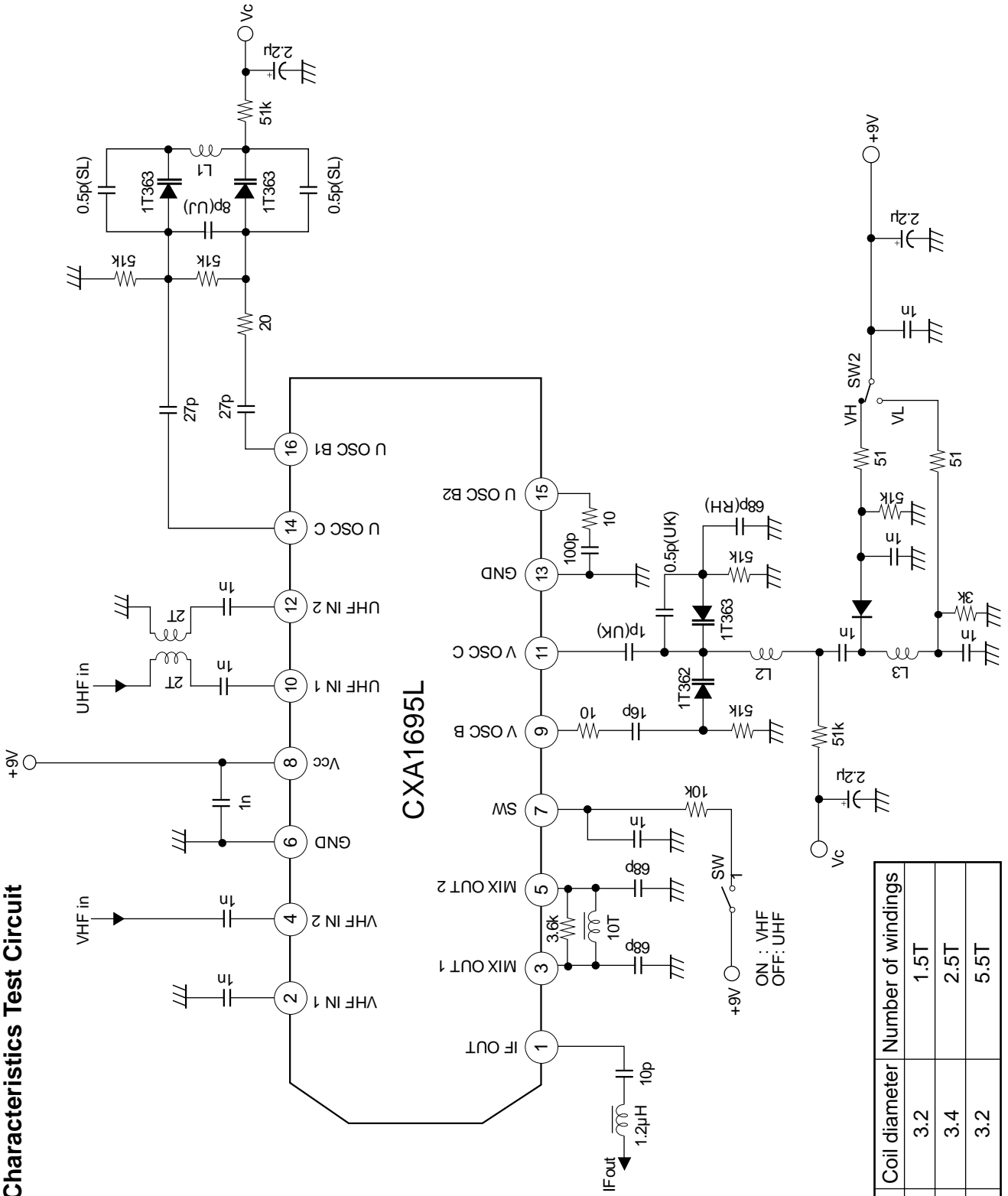

## Description of Operation (See Electrical Characteristics Test Circuit)

### (1) VHF oscillator circuit

The differential oscillator circuit with Pin 11 output and Pin 9 input.

Connect an LC resonance circuit comprising a varicap diode to Pin 11 through a coupling capacitor. The positive feedback from the resonance circuit is applied to Pin 9 through a feedback capacitor to execute oscillation. Note that if a parasitic capacitance across Pins 9 and 11 is too large, it may cause undesired oscillation.

### (2) VHF mixer circuit

This is a double-balanced mixer having small leakage of local oscillation signal. The RF signal input terminal are Pins 2 and 4. In normal use, the signal is input to one pin while the other pin is connected to GND by decoupling capacitor. The RF signal is converted to IF with the signal supplied from oscillator. The converted RF is sent to the IF amplifier and output to Pins 3 and 5 simultaneously.

### (3) UHF oscillator circuit

This is the differential oscillator same circuit as the VHF oscillator. In Electrical Characteristics Test Circuit, oscillation is executed as a Colpitts oscillator using one side transistor of the differential amplifier.

### (4) UHF mixer circuit

This is the double-balanced mixer same circuit as the VHF mixer. The RF signal input terminal are to Pins 10 and 12. These are used balanced differential input from pre-stage double tune circuit, or an unbalanced input to Pin 10 with the capacitor connected at Pin 12 to GND. Balanced input achieves better NF rather than unbalanced input.

Otherwise, the conditions and usage are the same as for the VHF mixer.

### (5) IF amplifier circuit

The mixer output signal is amplified by the IF amplifier and output to Pin 1. The output impedance is approximately  $75\Omega$ .

### (6) UHF/VHF switching circuit

UHF / VHF modes are switched by the DC voltage at Pin 7. UHF operation is for open or 0V; VHF operation, for 3V or more.

Normally, for internal protection UHF/VHF switch is performed by 9V or open through about  $10k\Omega$  resistor.

## Notes on Usage

Care should be taken in placing external parts because high frequencies are present. Adjust accordingly to prevent heat problems with special care for Pins 6 and 13 (GND) whose heat dissipation accumulate.

Example of Representative Characteristics

Circuit current vs. Supply voltage

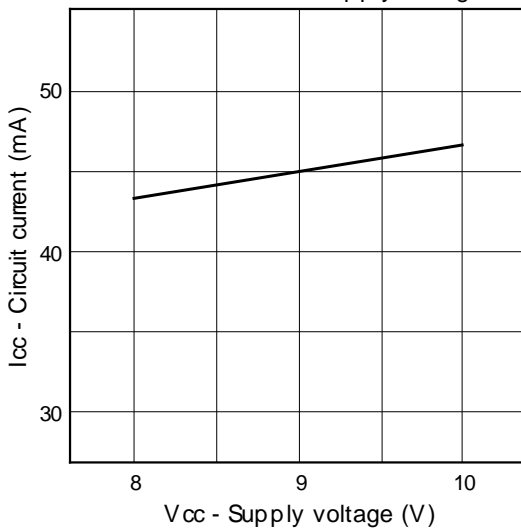

Conversion gain vs. Reception frequency (Untuned input)

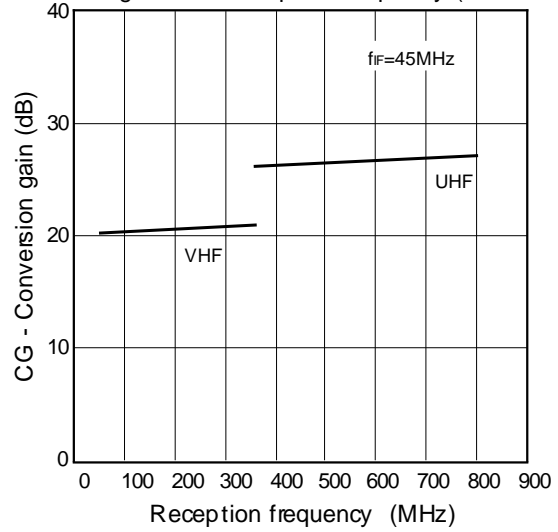

Noise figure vs. Reception frequency (Untuned input, in DSB)

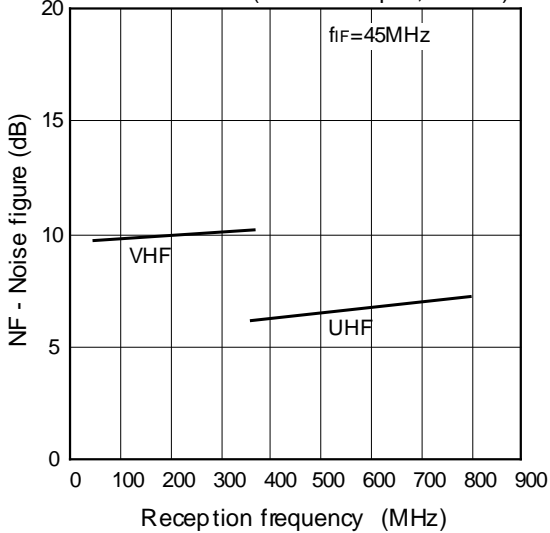

Next adjacent cross modulation vs. Reception frequency (Untuned input)

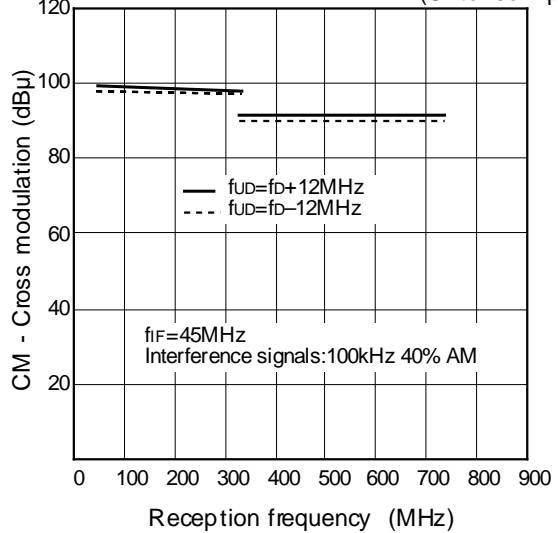

I/O characteristics (Untuned input)

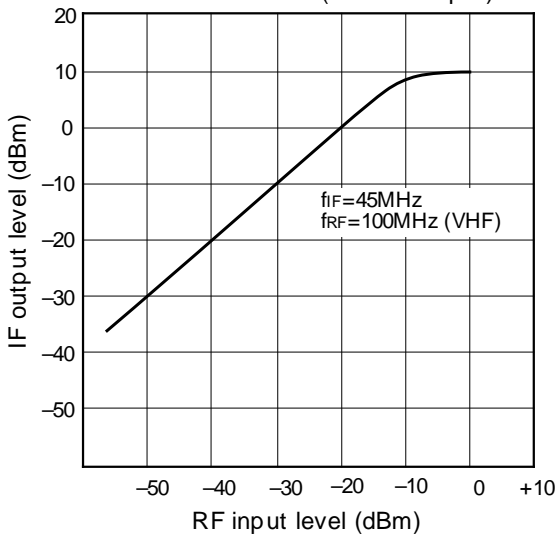

VHF Input Impedance

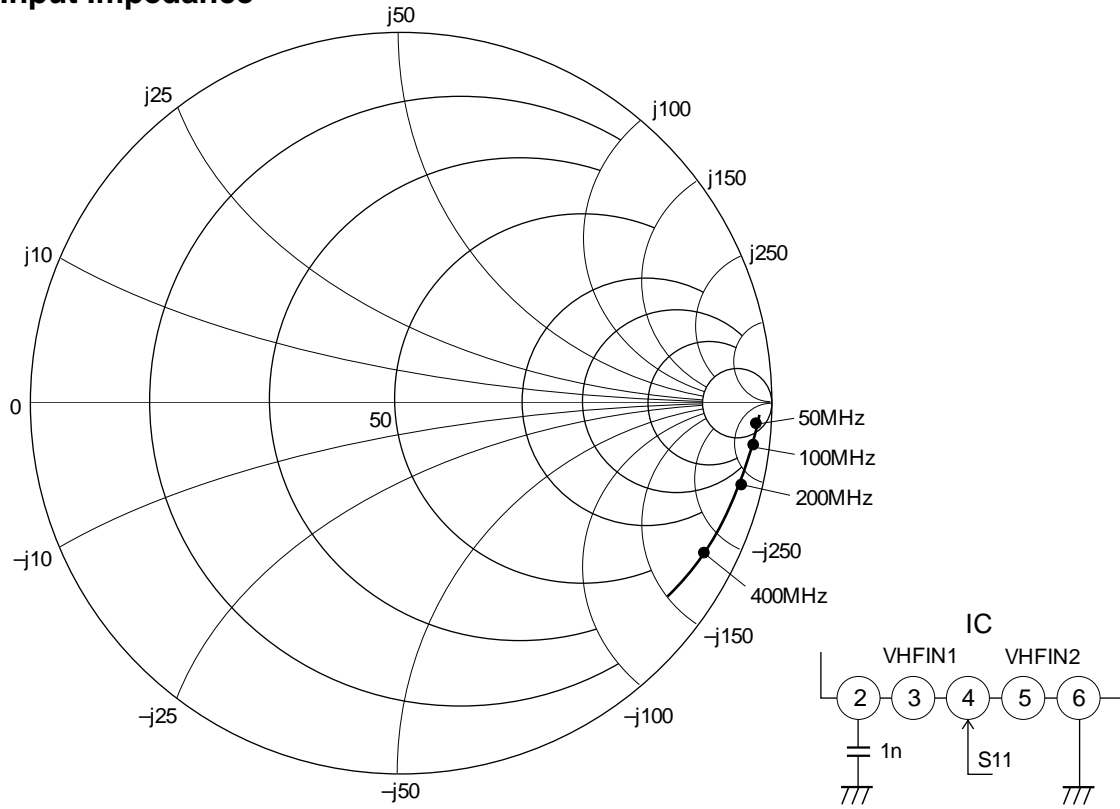

UHF Input Impedance

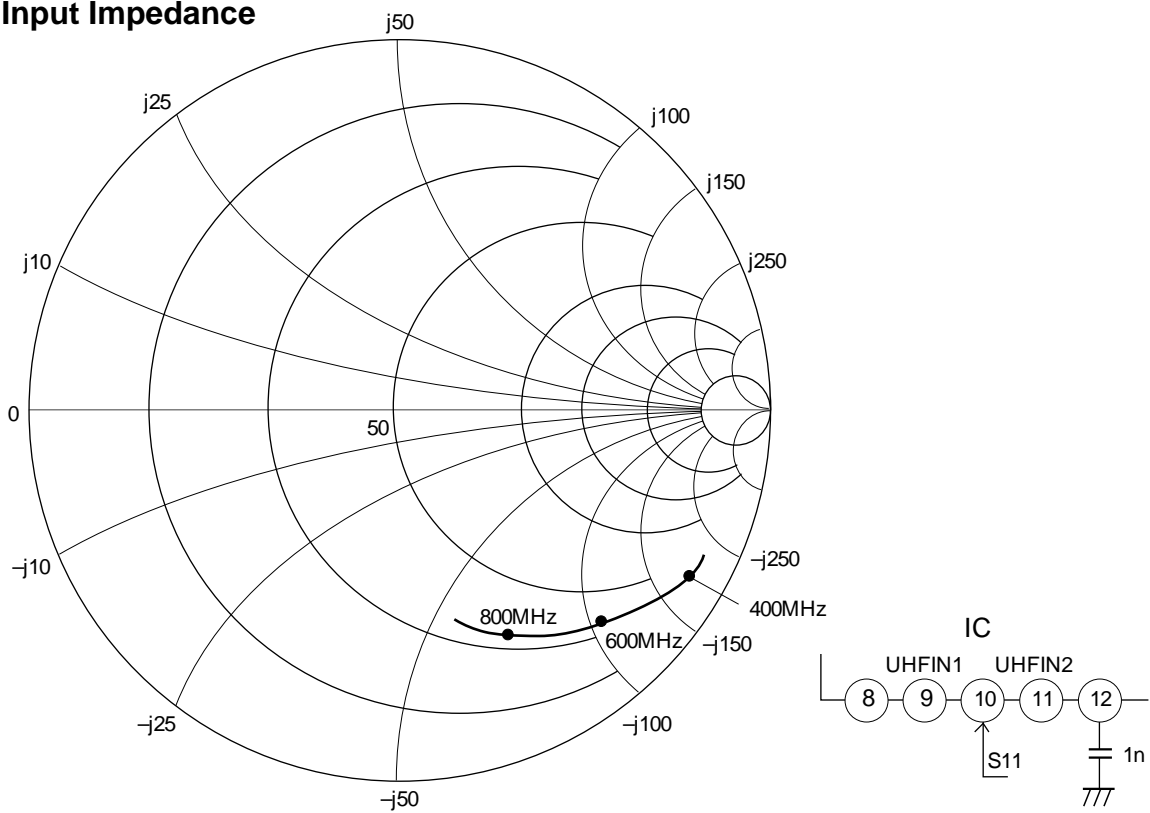

IF Output Impedance

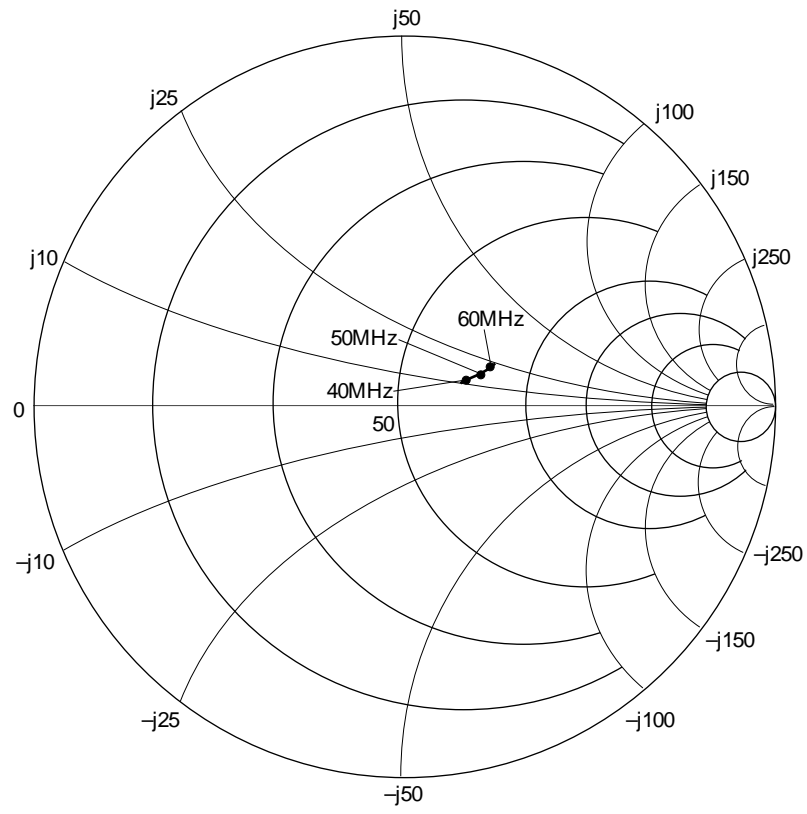



This datasheet has been downloaded from:

[www.DatasheetCatalog.com](http://www.DatasheetCatalog.com)

Datasheets for electronic components.



LittleDiode supplies new, hard to find or obsolete electronic components and semiconductors all over the world.

With over two million different components listed you are sure to find the part you need.

Feel free to visit us today at our online store:

**[LittleDiode.com](http://LittleDiode.com)**

Looking forward to providing you with the best possible service.