

Vocal Canceller for "Karaoke" Equipment

Description

The CXA1642P/M is a bipolar IC for use in "Karaoke" music entertainment systems that provides a built-in means of attenuating the vocal portions of recorded musical programs on CD, laser disks and other entertainment media.

Features

- Vocal cancel feature
- Low-level sound correction
- Internal MIX input amplifier
- Few external components

Absolute Maximum Ratings

- Supply voltage Vcc 12 V
- Operating temperature Topr -20 to +75 °C
- Storage temperature Tstg -65 to +150 °C
- Allowable power dissipation Pd 500 mW (CXA1642P)  
250 mW (CXA1642M)

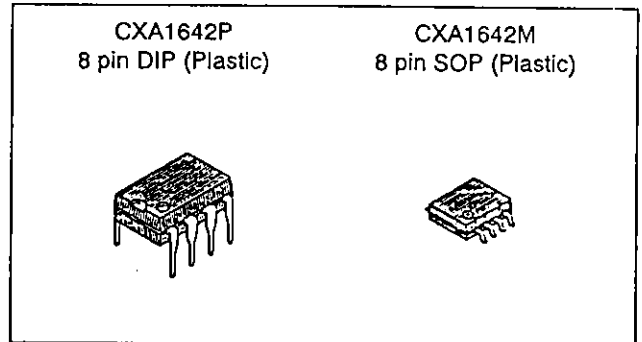

Applications

Use in all types of "Karaoke" audio systems to implement functions needed to allow singer's voice to override the originally recorded vocal track without disrupting the music tracks.

Structure

Bipolar silicon monolithic IC

Recommended Operating Conditions

Supply voltage 1.8 to 10.0 V

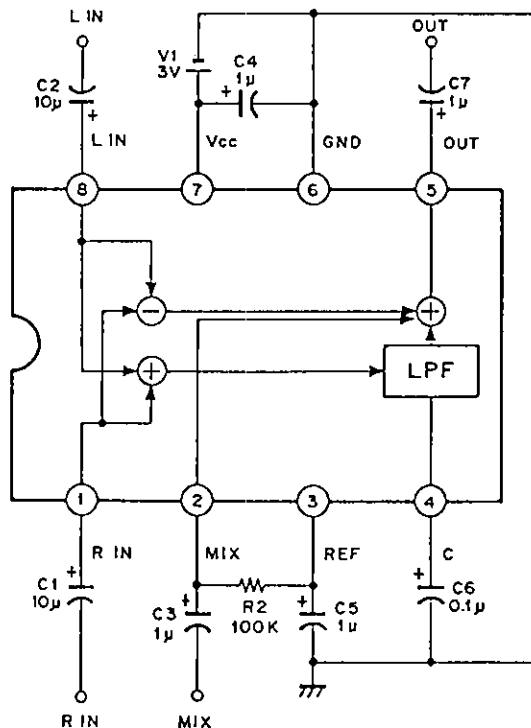

Block Diagram, Pin Configuration, and Application Circuit



Sony reserves the right to change products and specifications without prior notice. This information does not convey any license by any implication or otherwise under any patents or other right. Application circuits shown, if any, are typical examples illustrating the operation of the devices. Sony cannot assume responsibility for any problems arising out of the use of these circuits.

Pin Description

Pin No.	Symbol	Equivalent circuit	Pin voltage	Description
1	R_IN		5.0	R-channel input
2	MIX		5.0	Mixing input
3	REF		5.0	Reference pin
4	C		5.0	LPF time constant pin
5	OUT		5.0	Output

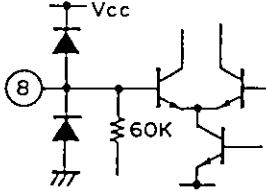
Pin No.	Symbol	Equivalent circuit	Pin voltage	Description
6	GND		0	GND
7	Vcc		10.0	Power supply
8	L_IN		5.0	L-channel input

Electrical Characteristics

(Ta=25°C, Vcc=10)

Test No.	Test item	SW conditions				Test point	Output waveform and test method	Min.	Typ.	Max.	Unit
		S1	S2	S3	S4						
1	Circuit current	OFF	OFF	OFF	OFF	I <sub>i</sub>	—	1.6	3.0	mA	
2	Mixer gain	ON			ON	V <sub>o</sub>	-1	0	1	dB	
3	Noise level	OFF			OFF	V <sub>o</sub>	—	-86	-70	dBm	
4	Vocal suppression			ON		V <sub>o</sub>	20	24	—	dB	
5	Low frequency gain					V <sub>o</sub>	-1	0	1	dB	

Electrical Characteristics Test Circuit

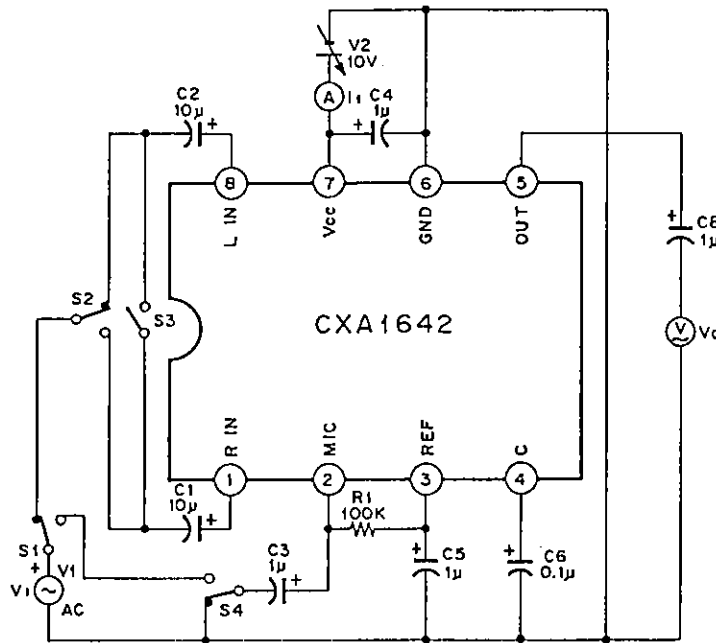

CXA1642 Vocal Elimination Ratio

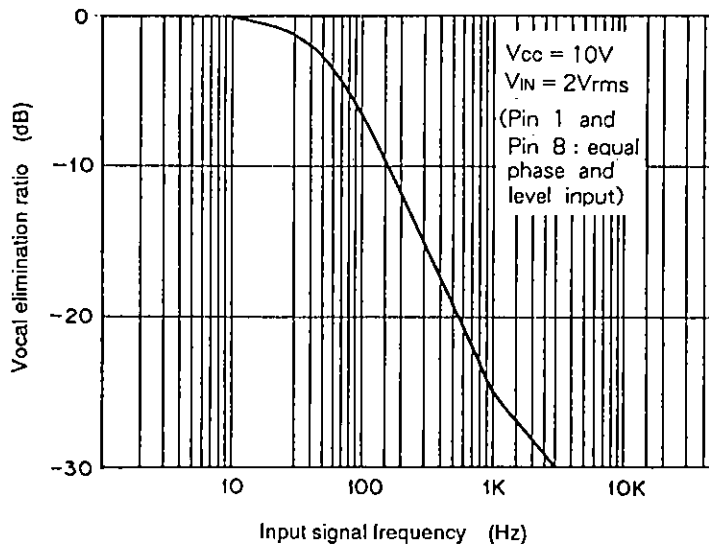

Package Outline Unit : mm

CXA1642P 8pin DIP (Plastic) 300mil 0.5g

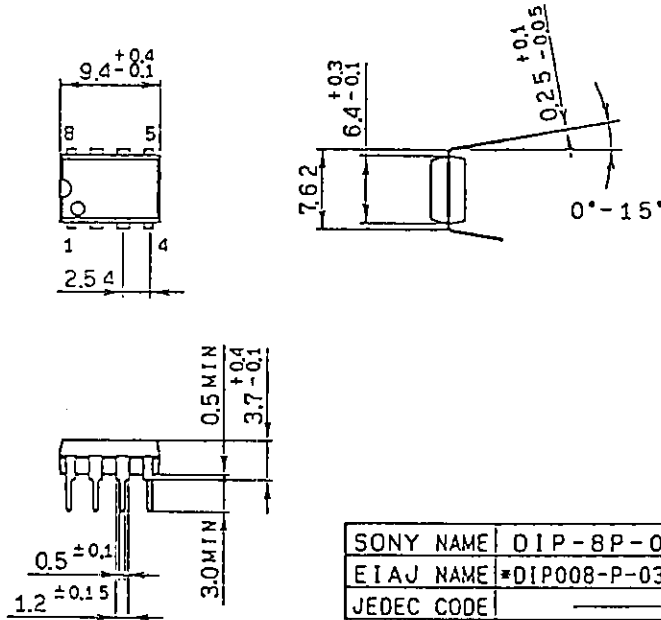

CXA1642M 8pin SOP (Plastic) 225mil

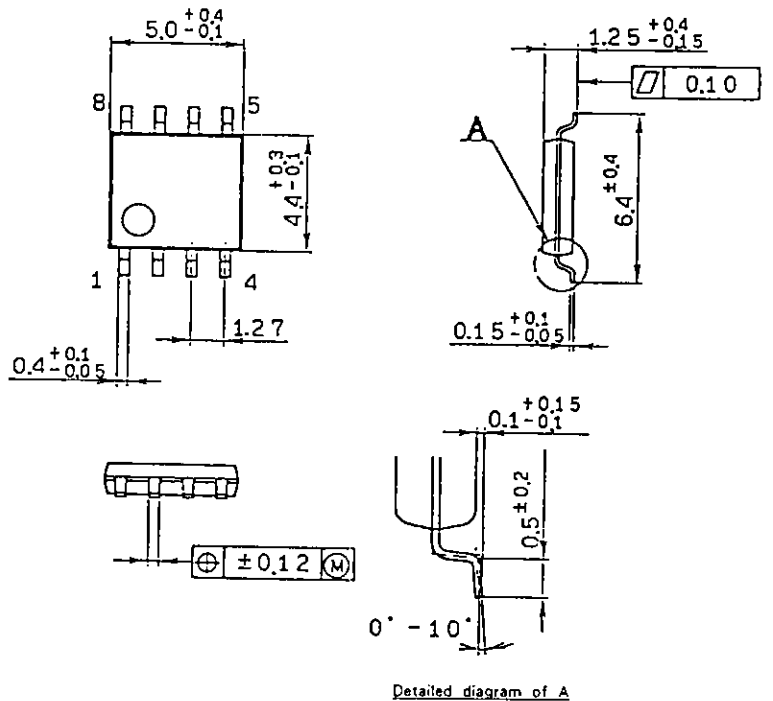

Detailed diagram of A

SONY NAME	SOP-8P-L03
EIAJ NAME	*SOP008-P-0225-A
JEDEC CODE	

This datasheet has been downloaded from:

[www.DatasheetCatalog.com](http://www.DatasheetCatalog.com)

Datasheets for electronic components.



LittleDiode supplies new, hard to find or obsolete electronic components and semiconductors all over the world.

With over two million different components listed you are sure to find the part you need.

Feel free to visit us today at our online store:

[LittleDiode.com](http://LittleDiode.com)

Looking forward to providing you with the best possible service.