

Stereo Power Amplifier/Monaural BTL Power Amplifier

Description

The CXA1622M/P is a bipolar IC developed as power amplifier for compact radio cassettes with built-in pre-amplifier and power amplifier electrical volume.

Features

- Use one channel in stereo mode
 - EIAJ output=110 mW (Typ.), $V_{CC}=3\text{ V}$, $R_L=8\ \Omega$ (CXA1622M)
 - EIAJ output=450 mW (Typ.), $V_{CC}=6\text{ V}$, $R_L=8\ \Omega$ (CXA1622P)
- BTL mode
 - EIAJ output=320 mW (Typ.), $V_{CC}=3\text{ V}$, $R_L=8\ \Omega$ (CXA1622M)
 - EIAJ output=360 mW (Typ.), $V_{CC}=3\text{ V}$, $R_L=8\ \Omega$ (CXA1622P)
- Built-in electrical volume
- Built-in ripple filter (ripple rejection 34.5 dB typ.)
- Selection between stereo power amplifier and monaural BTL power amplifier is possible by switching Pin 2.

Applications

Suitable for audio power amplifier for stereo and monaural radios and power amplifier for radio cassette and Walkman.

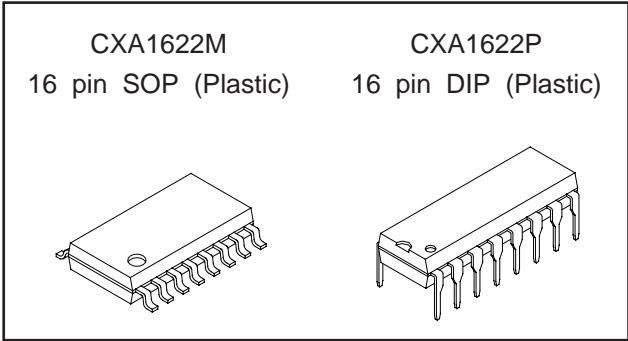

Structure

Bipolar silicon monolithic IC

Absolute Maximum Ratings ($T_a=25\text{ }^\circ\text{C}$)

- Supply voltage V_{CC} 8 V
- Operating temperature T_{opr} $-10\text{ to }+60\text{ }^\circ\text{C}$
- Storage temperature T_{stg} $-65\text{ to }+150\text{ }^\circ\text{C}$
- Allowable power dissipation
 - P_D 410 (CXA1622M) mW
 - 1200 (CXA1622P) mW

Operating Conditions ($T_a=25\text{ }^\circ\text{C}$)

- Supply voltage
- Stereo mode
 - 1.8 V to 4.5 V (CXA1622M)
 - 1.8 V to 7.0 V (CXA1622P)
- Monaural BTL mode 1.8 V to 4.5 V
(3 V recommended)

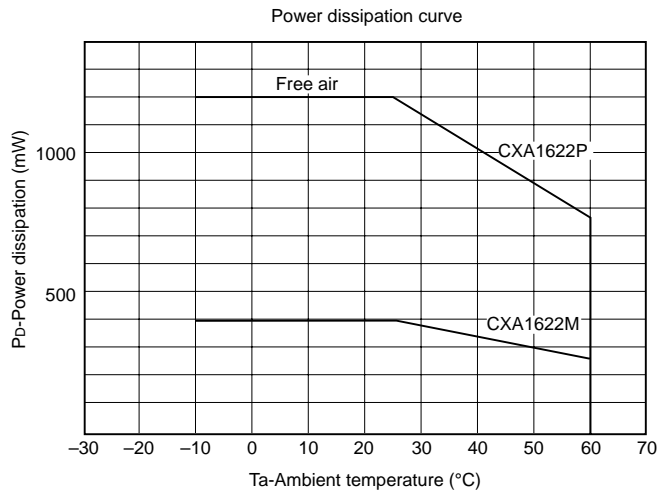

Sony reserves the right to change products and specifications without prior notice. This information does not convey any license by any implication or otherwise under any patents or other right. Application circuits shown, if any, are typical examples illustrating the operation of the devices. Sony cannot assume responsibility for any problems arising out of the use of these circuits.

Pin Description

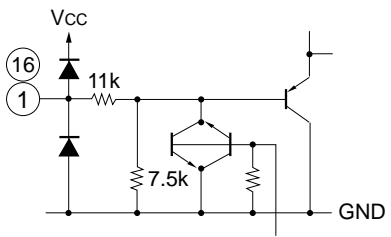
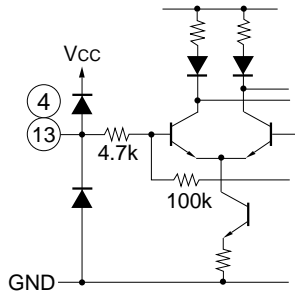
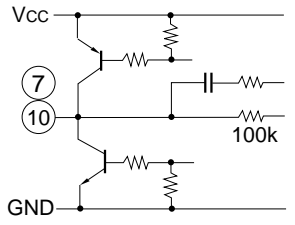
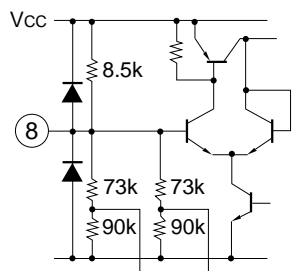
Pin No.	Symbol	Equivalent circuit	Pin voltage		Description
			3 V	6 V	
1, 16	IN1 IN2		0	0	Input
3	NC		—	—	
4, 13	NF1 NF2		1.5	3	Power amplifier NF. Connected to time constant 4.7 μF.
5, 12	GND1 GND2		0	0	Pre-amplifier GND
6, 11	P-GND1 P-GND2		0	0	Power amplifier GND
7, 10	OUT1 OUT2		1.5	3	Power amplifier output
8	RIPPLE		2.72	5.43	Connected to time constant 10 μF for ripple filter.
9	Vcc		3	6	Vcc

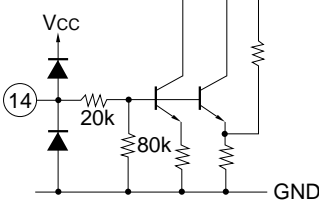
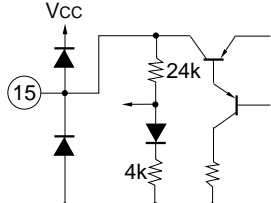
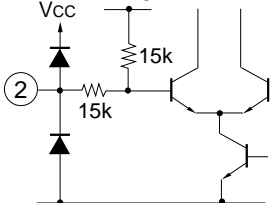
Pin No.	Symbol	Equivalent circuit	Pin voltage		Description
			3 V	6 V	
14	VOL		0 to 1.25	0 to 1.25	Control gain with change in voltage (0 to 1.25 V) to electrical volume control pin.
15	REG		1.25	1.25	Regulator pin
2	SW		1.25	1.25	Mode selection SW • BTL mode when open • Stereo mode when connected to GND

Block Diagram, Pin Configuration, and Application Circuit

1) Stereo mode

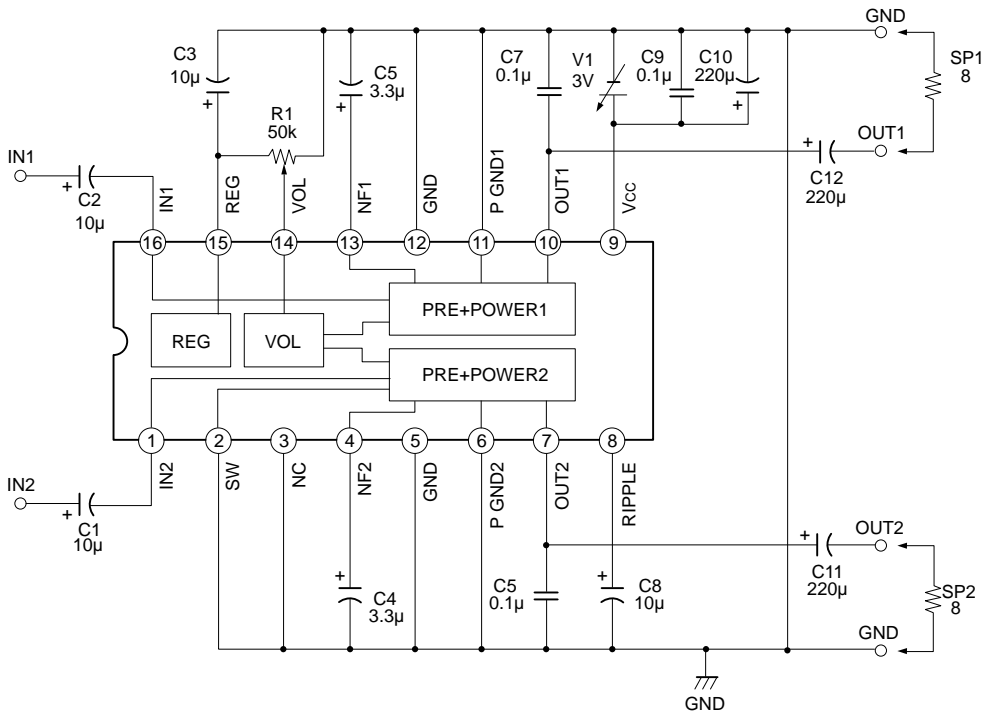

2) BTL mode

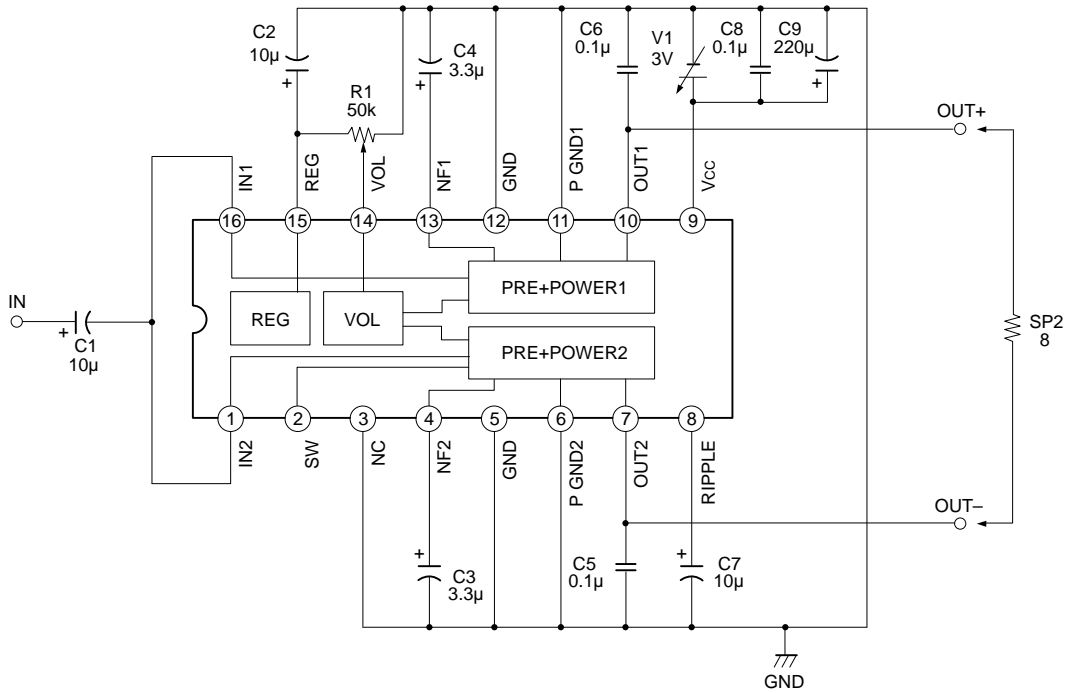

- * The input signal enters the pre-amplifier with attenuation controlled with DC at Pin 14 and then it is amplified by the approximately 30 dB (fixed) power amplifier.
- * The state of Pin 2 can be used to select between stereo mode and monaural BTL mode. The pre-power 1 and pre-power 2 output are positive phase output when Pin 2 is GND. Pre-power 2 is inverse output of pre-power 1 output when Pin 2 is open.

Application circuits shown are typical examples illustrating the operation of the devices. Sony cannot assume responsibility for any problems arising out of the use of these circuits or for any infringement of third party patent and other right due to same.

Stereo mode { Upper : CXA1622M (V_{CC}=3 V)
Lower : CXA1622P (V_{CC}=6 V)

Function block	Test No.	Test item	BIAS SW conditions														Input point	Input waveform and bias description	Test point	Output waveform and description of test method	Min.	Typ.	Max.	Unit
			S1	S2	S3	S4	S5	S6	S7	S8	S9	S10	S11	S12	S13	S14								
Typical conditions for each bias																								
	1	Circuit current during no signal	OFF	OFF	OFF	ON	OFF	OFF	OFF	OFF	OFF	OFF	OFF	OFF	OFF	OFF	OFF	OFF	I ₁	Circuit current during no signal	1.0	3.0	8.2	mA
	2	Audio voltage gain Lch	ON	ON	OFF														V ₄	V _I =-40 dBm 1 kHz	28	33.7	38	dB
	3	Audio voltage gain Rch		OFF	ON														V ₅	V _I =-40 dBm 1 kHz	28	33.7	38	dB
	4	Channel balance																	V ₄ V ₅	L and R channel balance	-3	0	3	dB
	5	Attenuation Lch		ON	OFF						ON								V ₄	V _I =-40 dBm 1 kHz Output level difference between max volume and half volume	1.5	5.8	12	dB
	6	Attenuation Rch		OFF	ON														V ₅	V _I =-40 dBm 1 kHz Output level difference between max volume and half volume	1.5	5.8	12	dB
	7	EIAJ output Lch		ON	OFF														V ₄	V _I =-20 dBm 1 kHz, R _L =8 Ω Output level where THD=10 %	350	450		mW
	8	EIAJ output Rch		OFF	ON														V ₅	V _I =-20 dBm 1 kHz, R _L =8 Ω Output level where THD=10 %	350	450		mW
	9	Audio distortion factor Lch		ON	OFF														V ₄	V _I =-20 dBm 1 kHz, R _L =8 Ω Distortion factor when output is 50 mW		0.7	2.5	%
	10	Audio distortion factor Rch		OFF	ON														V ₅	V _I =-20 dBm 1 kHz, R _L =8 Ω Distortion factor when output is 50 mW		0.7	2.5	%
	11	Residual noise level Lch	OFF	OFF	OFF														V ₄	Noise level during no signal at max volume		-65	-60	dBm
	12	Residual noise level Rch																	V ₅	Noise level during no signal at max volume		-65	-60	dBm
	13	Crosstalk L → R	ON	ON																V _I =-40 dBm 1 kHz Rch output level when Lch is input		-60	-56	dBm
	14	Crosstalk R → L		OFF	ON															V _I =-40 dBm 1 kHz Lch output level when Rch is input		-60	-56	dBm

Electrical Characteristics Test Circuit

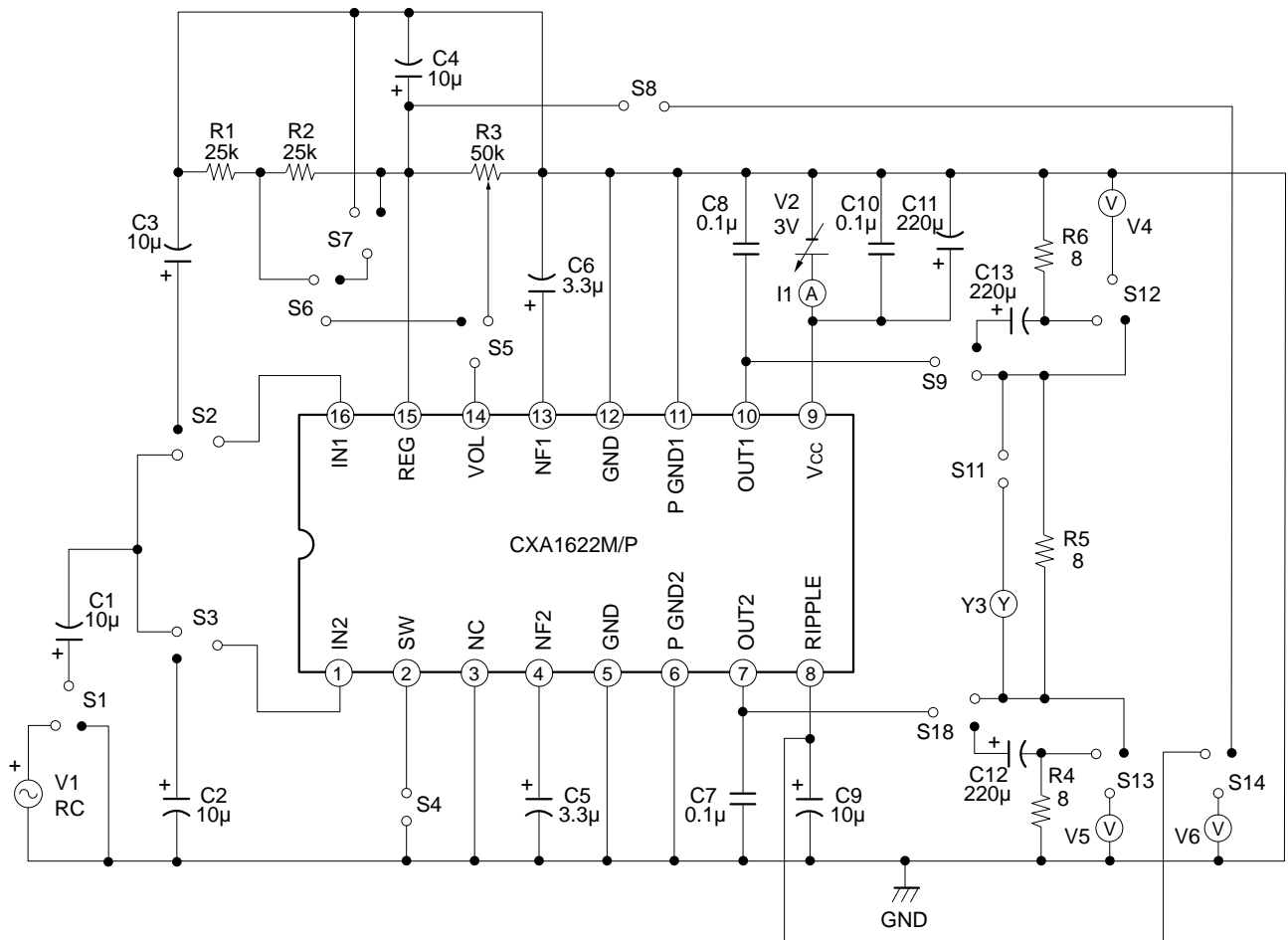

Notes on Operation

- Set print pattern to low impedance because Pins 6 and 11 are GND of power amplifier output stage.
- The value of the phase correction capacitance attached to Pins 7 and 10 varies slightly according to the print pattern.
- Provide a large land for DIP type Pin 5 because it also serves as heat dissipation pin.
- Place the by-pass capacitor of Vcc (Pin 9) as close to the pin as possible.

Stereo output single mode

* Keep the by-pass capacitor close to the IC pins

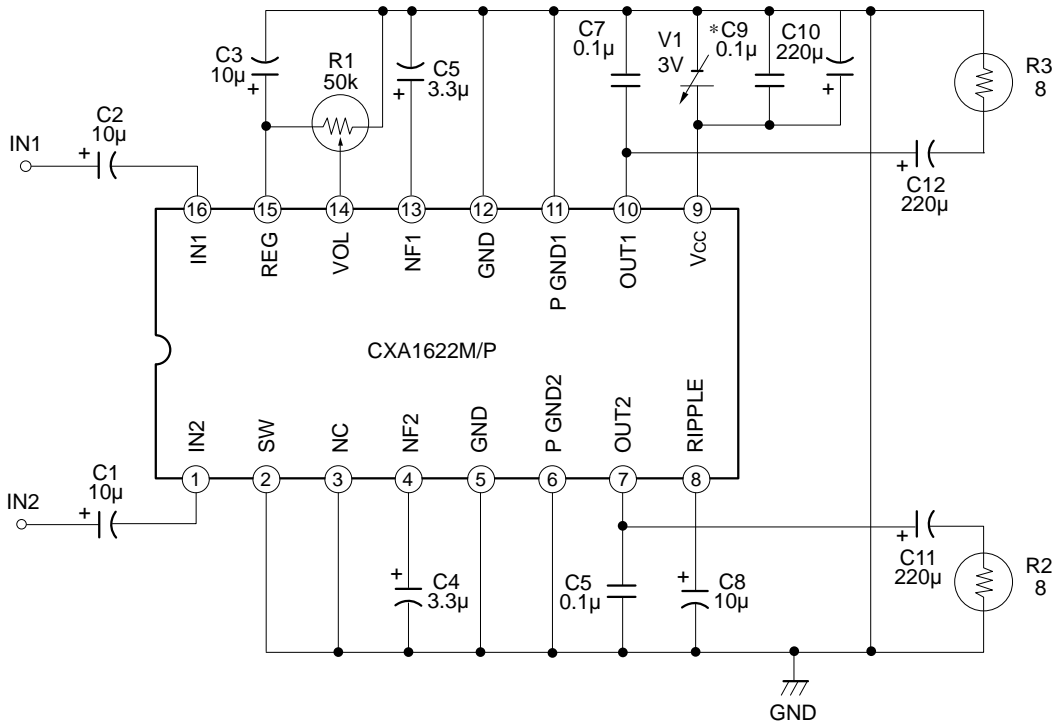

Monaural output BTL mode

* Keep the by-pass capacitor close to the IC pins

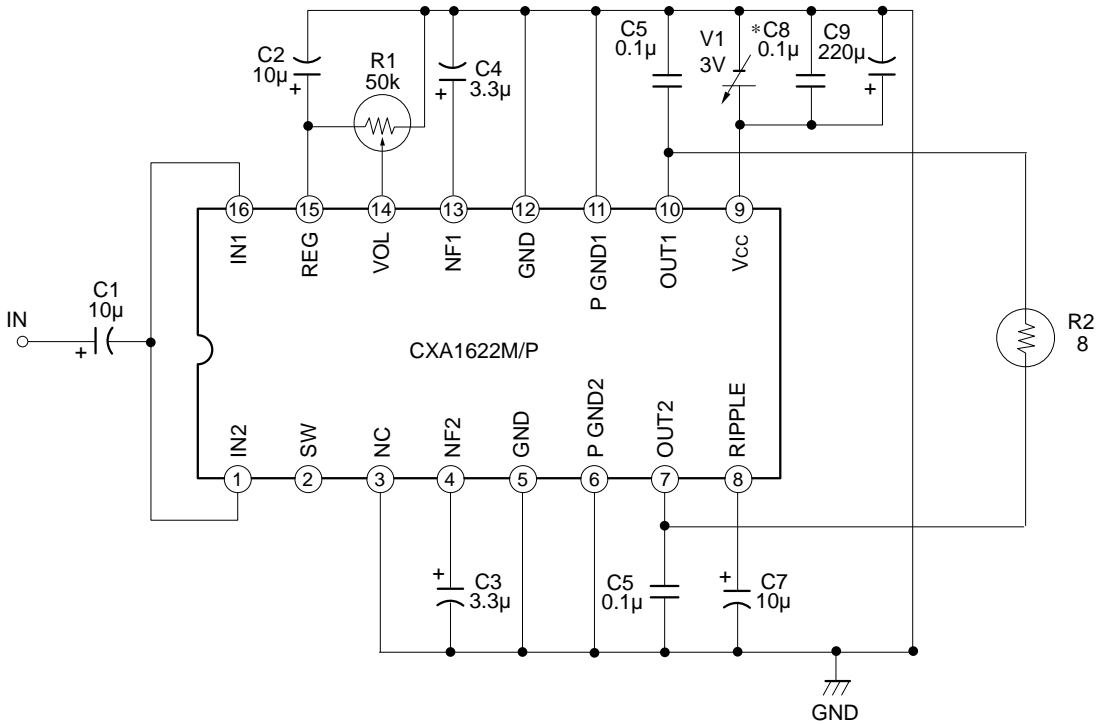

When using internal IC electrical volume in BTL mode

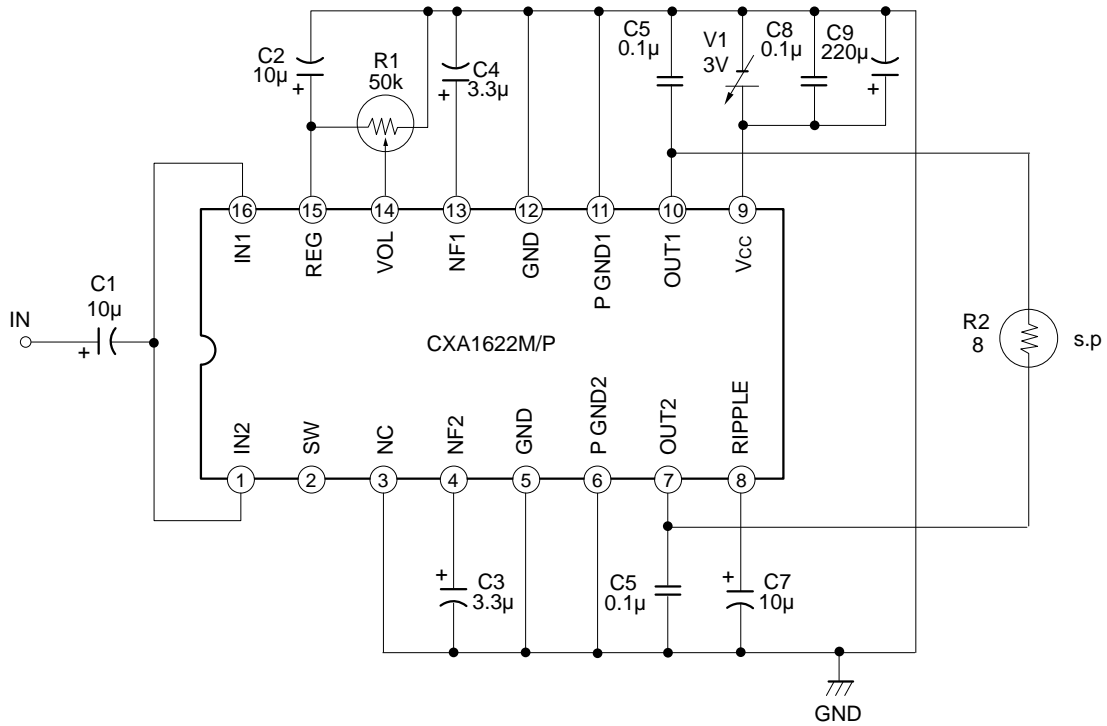

When using IC as fixed gain amplifier in BTL mode
Pin14 → GND (IC Gain MAX)

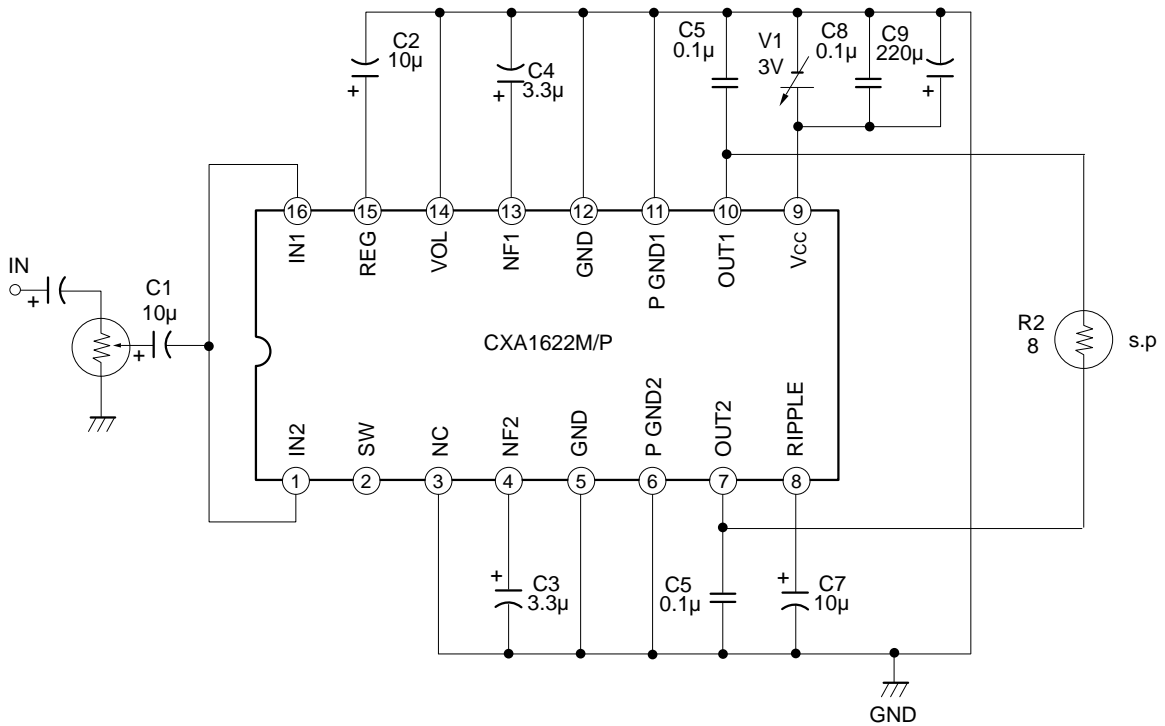

BTL, Stereo Application Circuit

When using internal IC electrical volume

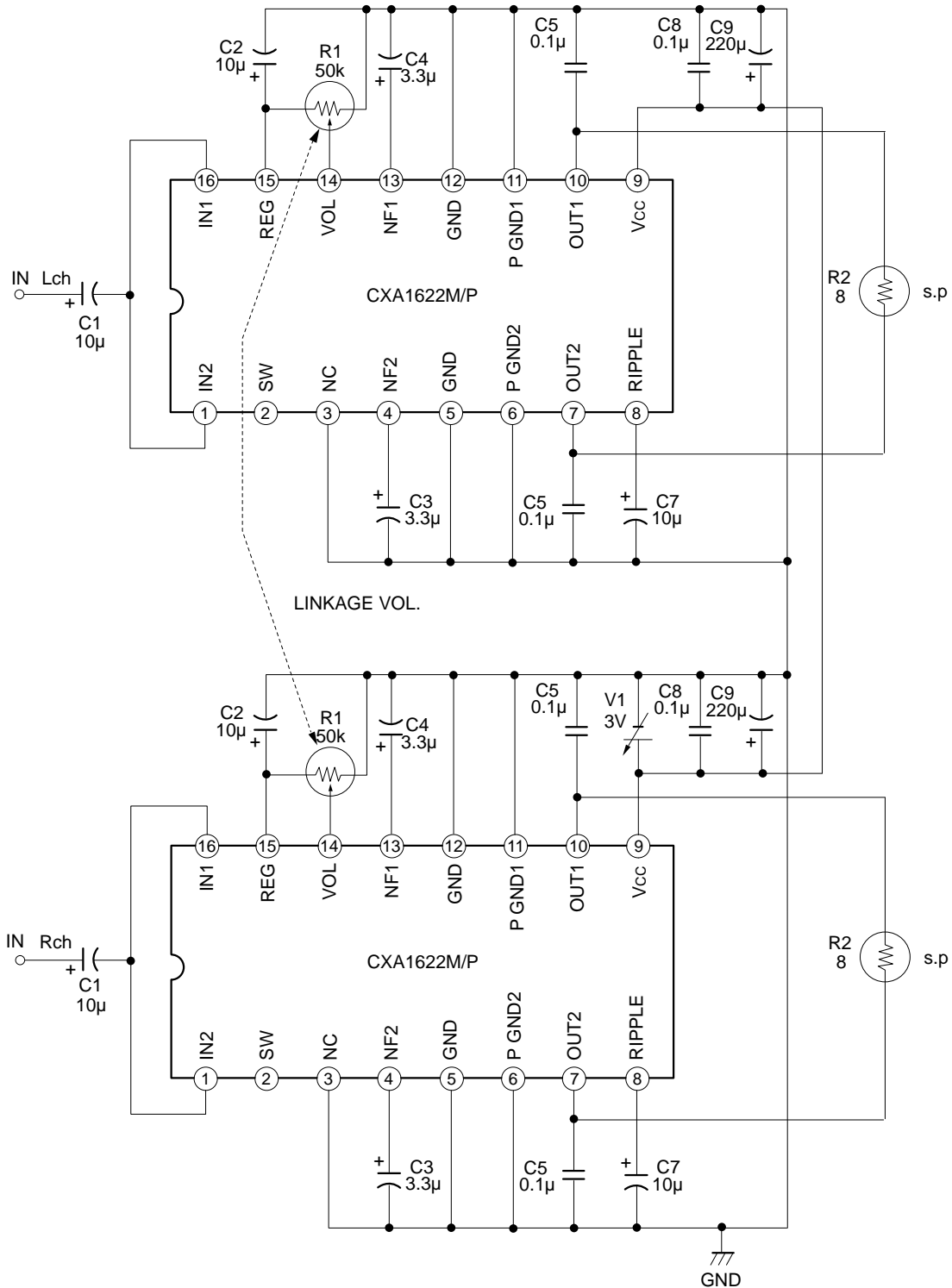

Application circuits shown are typical examples illustrating the operation of the devices. Sony cannot assume responsibility for any problems arising out of the use of these circuits or for any infringement of third party patent and other right due to same.

BTL, Stereo Application Circuit

When using IC as fixed gain amplifier

Pin14 → GND (IC Gain Max)

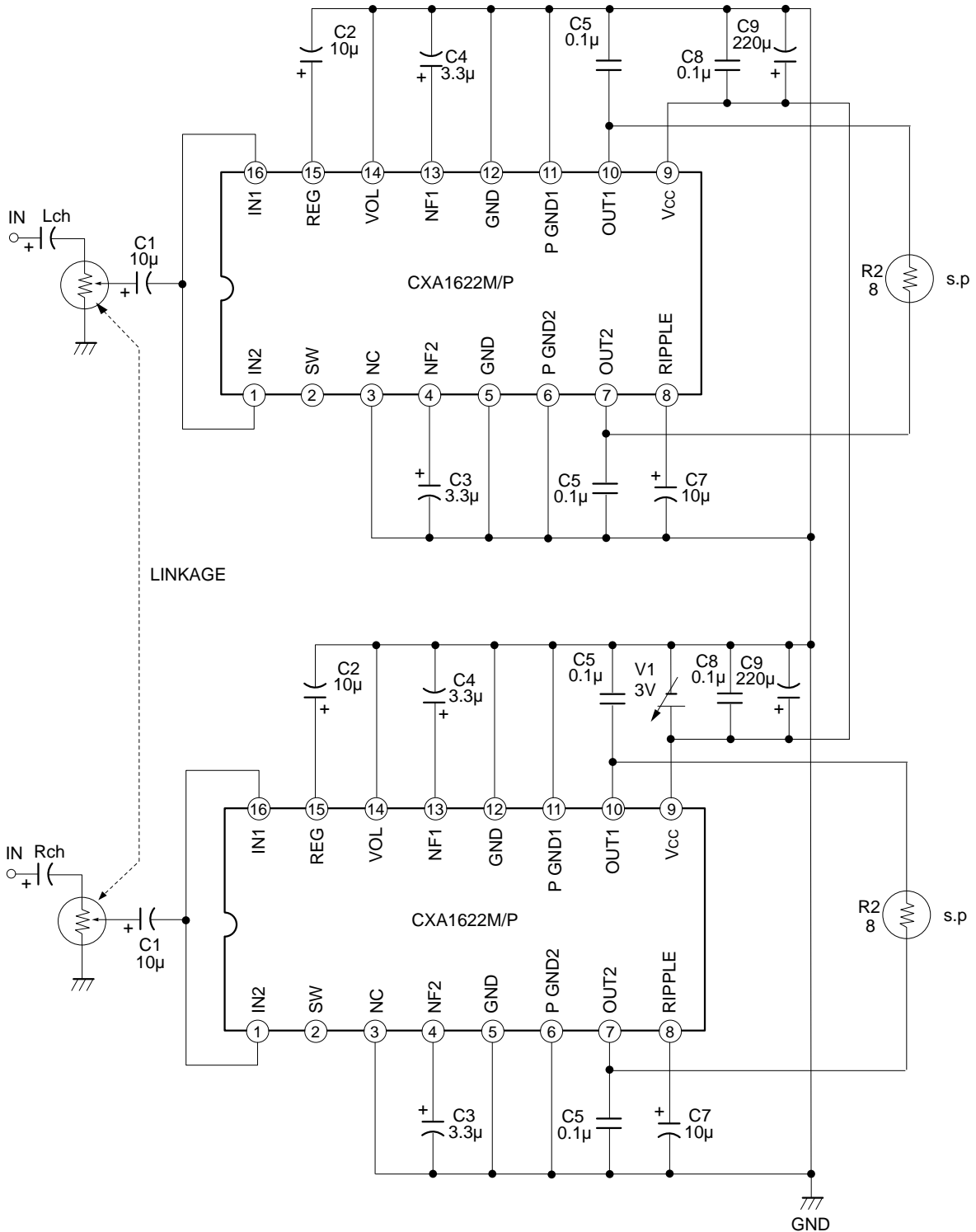

Application circuits shown are typical examples illustrating the operation of the devices. Sony cannot assume responsibility for any problems arising out of the use of these circuits or for any infringement of third party patent and other right due to same.

Output vs Distortion 1 CXA1622P
stereo mode single-channel input

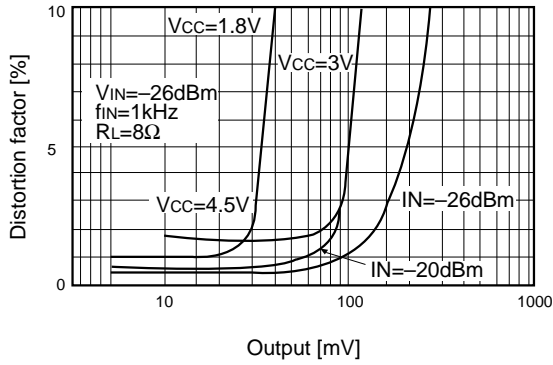

Output vs Distortion 2 CXA1622M
stereo mode single-channel input

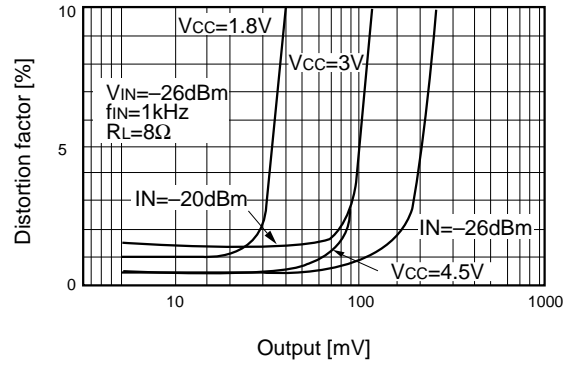

Output vs Distortion factor 3
CXA1622P BTL mode

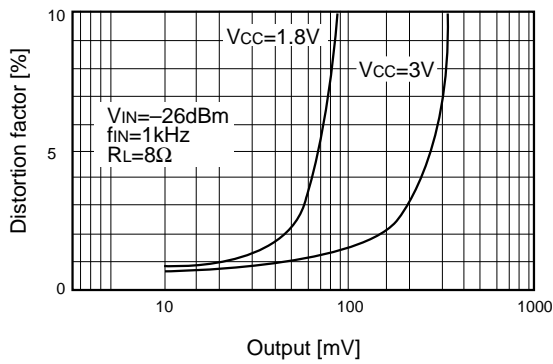

Output vs Distortion 4 CXA1622M BTL mode

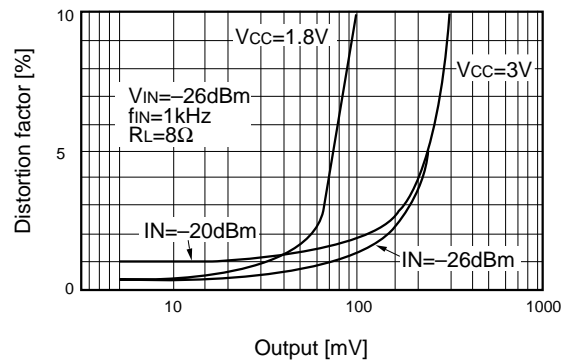

Stereo mode frequency characteristics
VIN=-40dBm VOL MAX VCC=3V

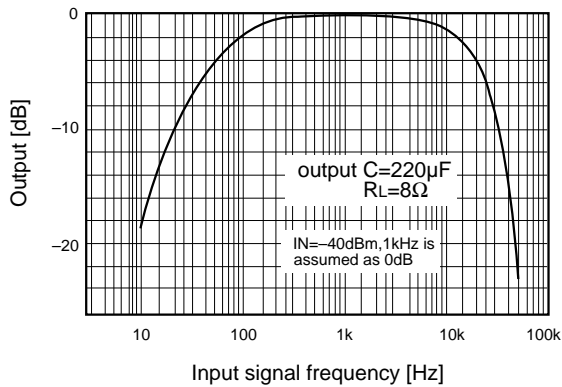

BTL mode frequency characteristics
VIN=-40dBm VOL MAX VCC=3V

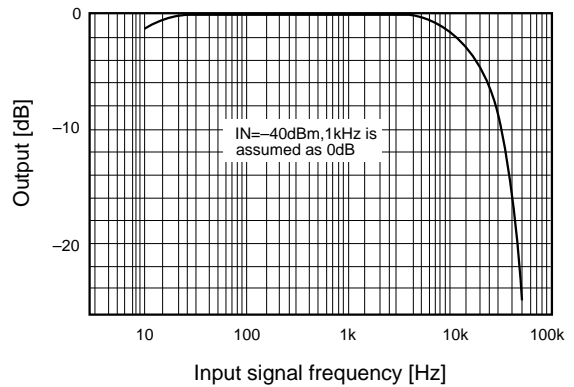

Package Outline Unit : mm

CXA1622M

16PIN SOP (PLASTIC)

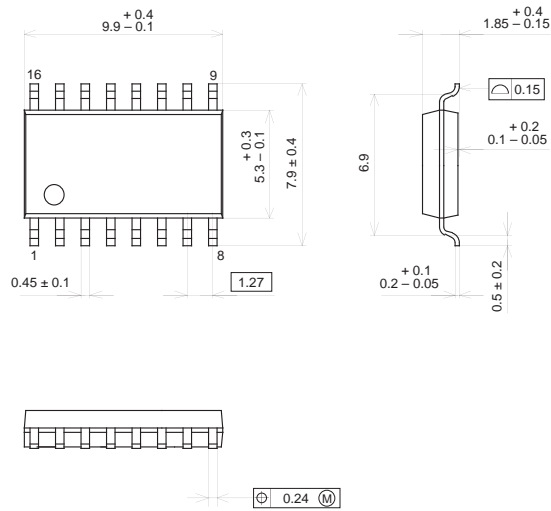

SONY CODE	SOP-16P-L01
EIAJ CODE	SOP016-P-0300
JEDEC CODE	

PACKAGE STRUCTURE

PACKAGE MATERIAL	EPOXY RESIN
LEAD TREATMENT	SOLDER PLATING
LEAD MATERIAL	COPPER ALLOY
PACKAGE MASS	0.2g

CXA1622P

16PIN DIP (PLASTIC)

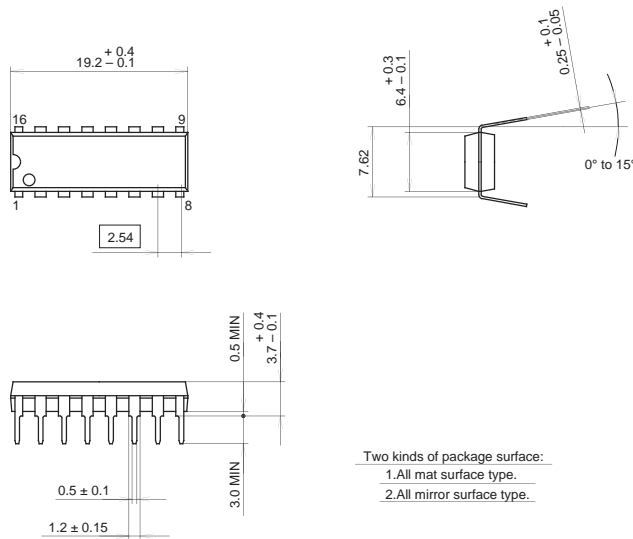

Two kinds of package surface:
 1. All mat surface type.
 2. All mirror surface type.

SONY CODE	DIP-16P-01
EIAJ CODE	DIP016-P-0300
JEDEC CODE	Similar to MO-001-AE

PACKAGE STRUCTURE

PACKAGE MATERIAL	EPOXY RESIN
LEAD TREATMENT	SOLDER PLATING
LEAD MATERIAL	COPPER ALLOY
PACKAGE MASS	1.0 g

This datasheet has been downloaded from:

www.DatasheetCatalog.com

Datasheets for electronic components.



LittleDiode supplies new, hard to find or obsolete electronic components and semiconductors all over the world.

With over two million different components listed you are sure to find the part you need.

Feel free to visit us today at our online store:

LittleDiode.com

Looking forward to providing you with the best possible service.