

Function Switch for Cassette tape recorder with radio

Description

The CXA1568S/M is a function selector switch IC for cassette tape recorders with radio and others. It is applicable to four stereo inputs and also incorporates a mixing amplifier with an AGC. Both the function and microphone outputs have mute function.

Features

- Function selector switch for four stereo inputs
- Mixing amplifier with an AGC
- Audio mute function
- Microphone mute function

Applications

Selector switches and mixing microphones for cassette tape recorder with radio or others

Structure

Bipolar silicon monolithic IC

22pin SDIP (Plastic)

24pin SOP (Plastic)

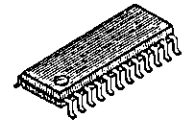
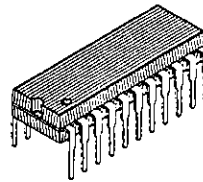

Absolute Maximum Ratings (Ta=25°C)

• Supply voltage	V _{CC}	12	V
• Operating temperature	T _{opr}	-20 to +75	°C
• Storage temperature	T _{stg}	-65 to +150	°C
• Allowable power dissipation	P _D	SOP 680mW SDIP 880mW	

Operating Condition

• Supply voltage	V _{CC}	4.5~10	V
------------------	-----------------	--------	---

Block Diagram

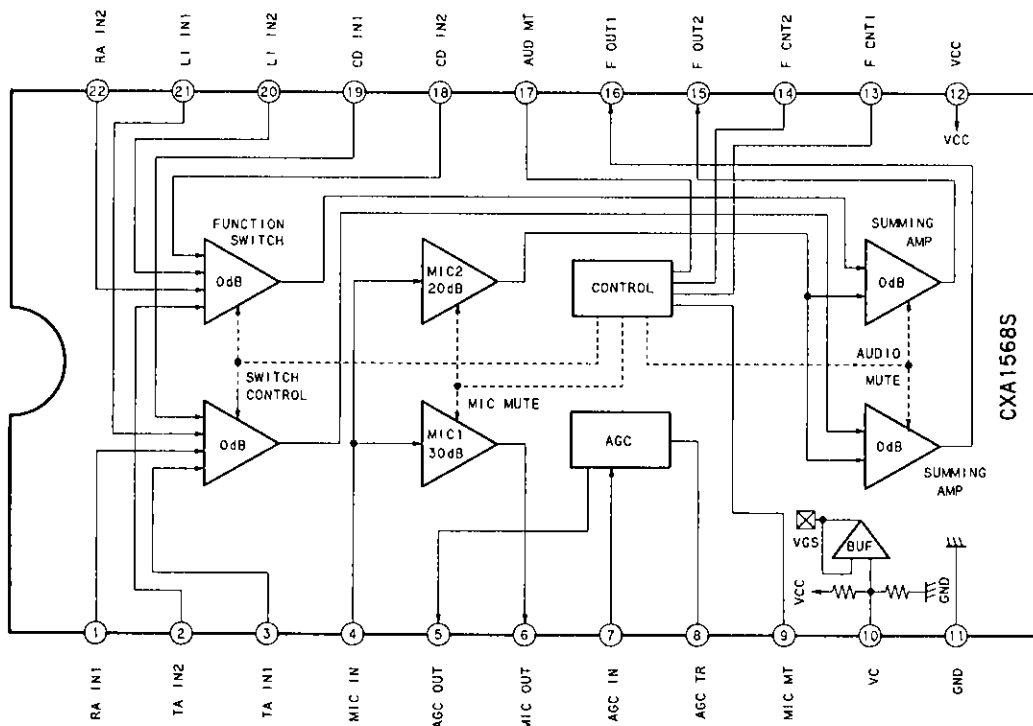

Pin Configuration

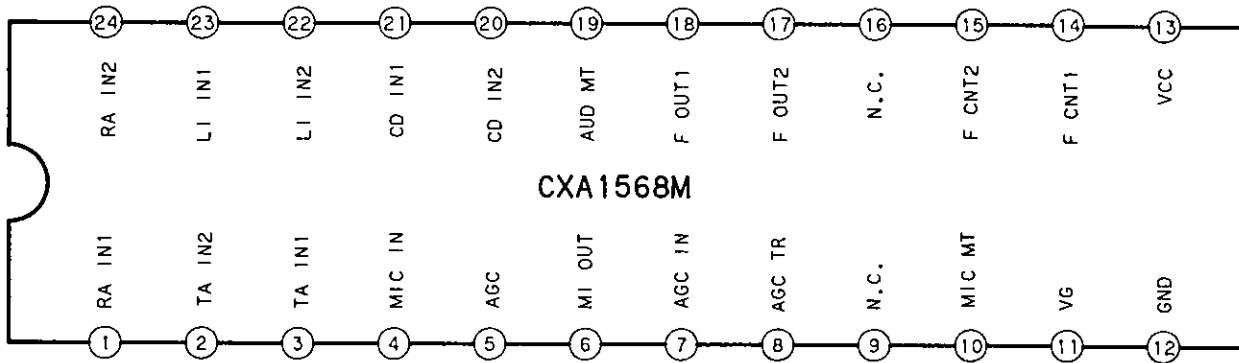
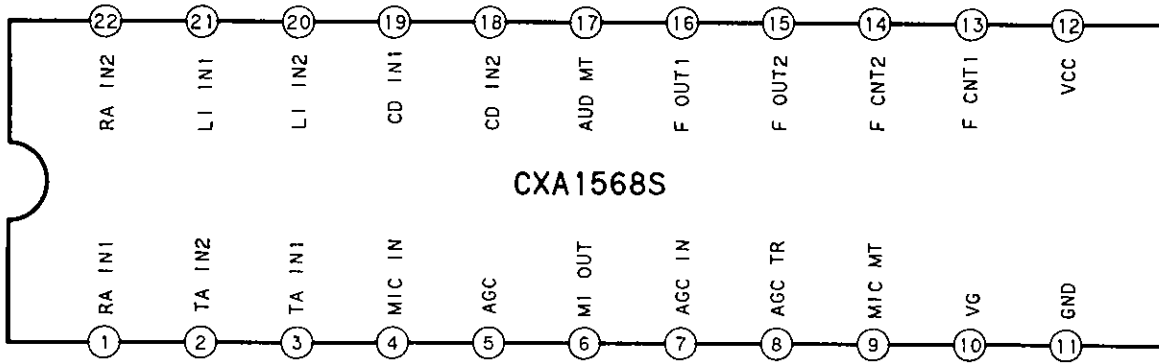

Pin Description and Equivalent Circuit

※ Pin No. is for 22-pin SDIP.

Pin No.	Symbol	DC voltage	I/O	Input resistance	Equivalent circuit	Description
3 2 1 22 21 20 19 18	TA IN1 TA IN2 RA IN1 RA IN2 LI IN1 LI IN2 CD IN1 CD IN2	$\frac{V_{CC}}{2}$	I	48kΩ		2 channels×4 source-signal input
4	MIC IN	$\frac{V_{CC}}{2}$	I	50kΩ		Mixing microphone signal input
5	AGC OUT	$\frac{V_{CC}}{2}$	O	100kΩ (No signal)		Varies output resistance according to input level to Pin 7. Variable range: 100kΩ to several 10sΩ
8	AGC TR	0V (No signal)	—	—		Connects external resistor and capacitor which determines time constant of AGC attack recovery.

Pin No.	Symbol	DC voltage	I/O	Input resistance	Equivalent circuit	Description
6 15 16	MIC OUT F OUT2 F OUT1	$\frac{V_{CC}}{2}$	O	147 Ω		Pin 6: microphone output Pins 15, 16: function output
7	AGC IN	$\frac{V_{CC}}{2}$	I	20k Ω		AGC input
9 13 14 17	MIC MT F CONT1 F CONT2 AUDIO MT	—	—	—		Pin 9: microphone mute control Pins 13, 14: function switch control Pin 17: function mute control * Mode is described later.
10	VG	$\frac{V_{CC}}{2}$	—	15k Ω		Connects ripple elimination capacitor of center electric potential
11	GND	0V	—	—		Ground
12	V _{CC}	V _{CC}	—	—		Power supply

Electrical Characteristics

Ta=25°C, V_{CC}=8.0V

Item	Symbol	Measurement conditions	Measurement conditions		Min.	Typ.	Max.	Unit
			IN	OUT				
Operating supply voltage	V _{opr}				4.5	8.0	10.0	V
Current consumption	I _{cc}	V _{CC} =8.0V TAPE mode, no signal			3.4	5.0	7.6	mA
Function output characteristics TAPE mode	FuTA	Sine wave, -30 dBm input f=20kHz	③ or ②	⑬ or ⑮	-1.0	0.0	1.0	dB
Function output characteristics RADIO mode	FuRA	Sine wave, -30 dBm input f=20kHz	① or ⑫	⑬ or ⑮	-1.0	0.0	1.0	dB
Function output characteristics CD mode	FuCD	Sine wave, -30 dBm input f=40kHz	⑰ or ⑱	⑬ or ⑮	-1.0	0.0	1.0	dB
Function output characteristics LINE IN mode	FuLI	Sine wave, -30 dBm input f=20kHz	⑳ or ㉑	⑬ or ⑮	-1.0	0.0	1.0	dB
Function output mute	FuMT	Sine wave, 0 dBm input f=1kHz, CD mode	⑰ or ⑱	⑬ or ⑮	-	-69	-64	dB
Function output total harmonic distortion	FuTHD	Sine wave, 0 dBm input f=1kHz, TAPE mode	③ or ②	⑬ or ⑮	-	0.01	0.15	%
Function output noise level	FuN	Rg=2.2 kΩ "A" WTG filter		⑬ or ⑮	-	-103	-90	dBm
Function output offset	FuOFF	Each mode, no signal			3.85	4.00	4.15	V
Function output offset fluctuation	FuΔOF	Fluctuation ratio for mode switching at TAPE mode			-20	0	+20	mV
Microphone output characteristics	Mic	Sine wave, -50 dBm input f=1 kHz	④⑤	⑥⑦	28	30	32	dB
Mixing output characteristics 1	Mix1	Sine wave, -50 dBm input f=1 kHz, RADIO mode	④⑤	⑬ or ⑮	18	20	22	dB
Mixing output characteristics 2	Mix2	Sine wave, -35 dBm input f=1 kHz, TAPE mode	④⑤	⑬ or ⑮	-	-52	-43	dB
Microphone output mute	MiMT	Sine wave, -35 dBm input f=1 kHz	④⑤	⑥⑦	-	-75	-70	dB
Microphone output total harmonic distortion	MiTHD	Sine wave, -50 dBm input f=1 kHz	④⑤	⑥⑦	-	0.13	0.3	%
Microphone output noise level	MiN	Rg=4.7 kΩ "A" WTG filter		⑥⑦	-	-80	-75	dBm
Microphone output offset	MiOFF	No signal			3.83	3.94	4.12	V

Item	Symbol	Measurement conditions	Measurement points		Min.	Typ.	Max.	Unit
			IN	OUT				
Microphone output offset fluctuation	Mi Δ OF	Fluctuation ratio For microphone mute at Mic OFF			-20	60	130	mV
AGC level	Agc	Sine wave, -30 dBm input f=1 kHz	④⑤	⑥⑦	-11	-9	-7	dBm
AGC total harmonic distortion	AgcN	Sine wave, -20 dBm input f=1 kHz	④⑤	⑥⑦	—	0.1	0.8	%
Control voltage high level	VCH	Threshold voltage at mode control pin			2.5	—	V _{CC}	V
Control voltage low level	VCL	Threshold voltage at mode control pin			GND	—	1.0	V

Electrical Characteristics Test Circuit

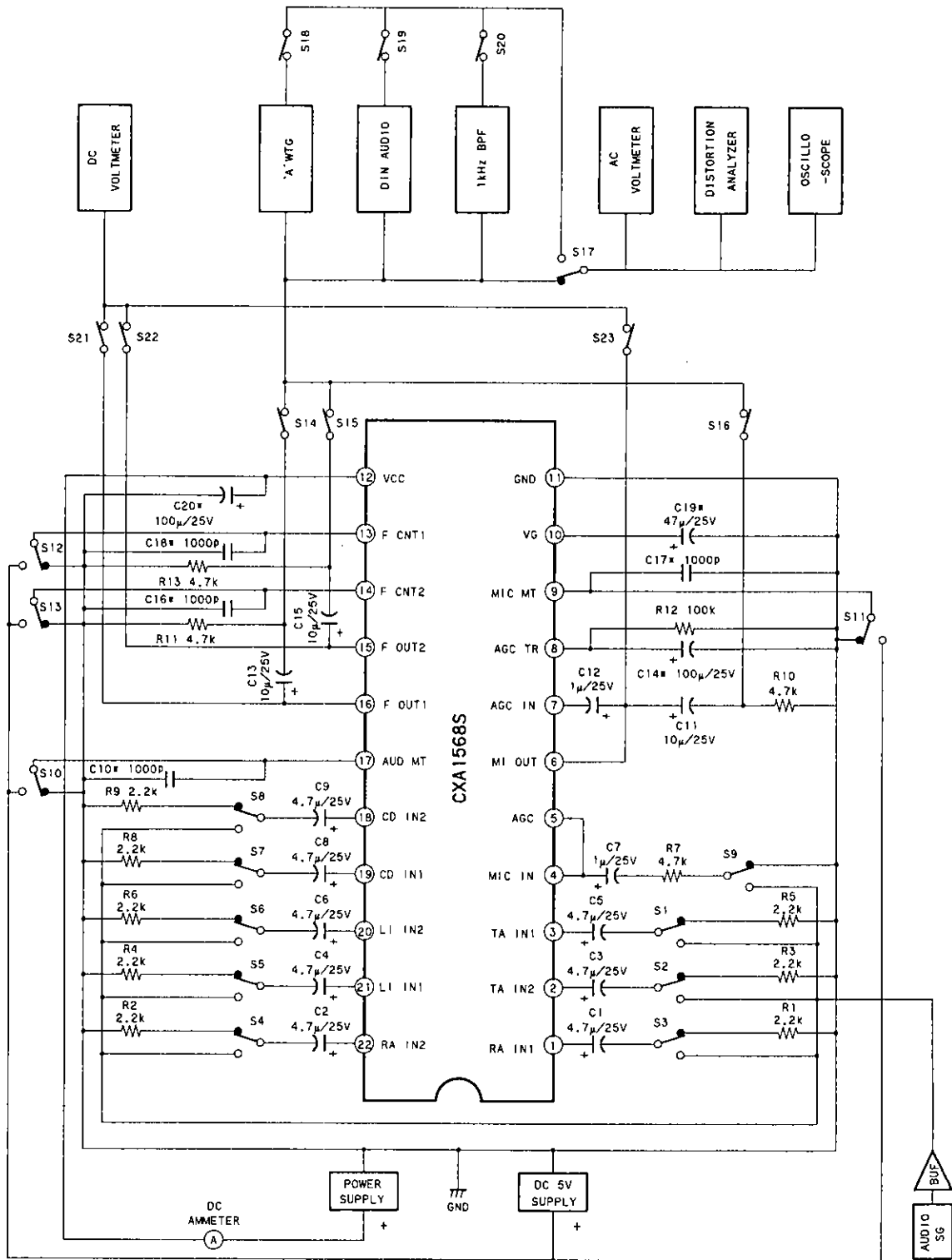

Note 1. Resistor tolerance * ±5%
 ±1%
 2. Capacitor tolesance * ±5%
 ±2%
 Coupling Capacitor ±10%

Application of Operation

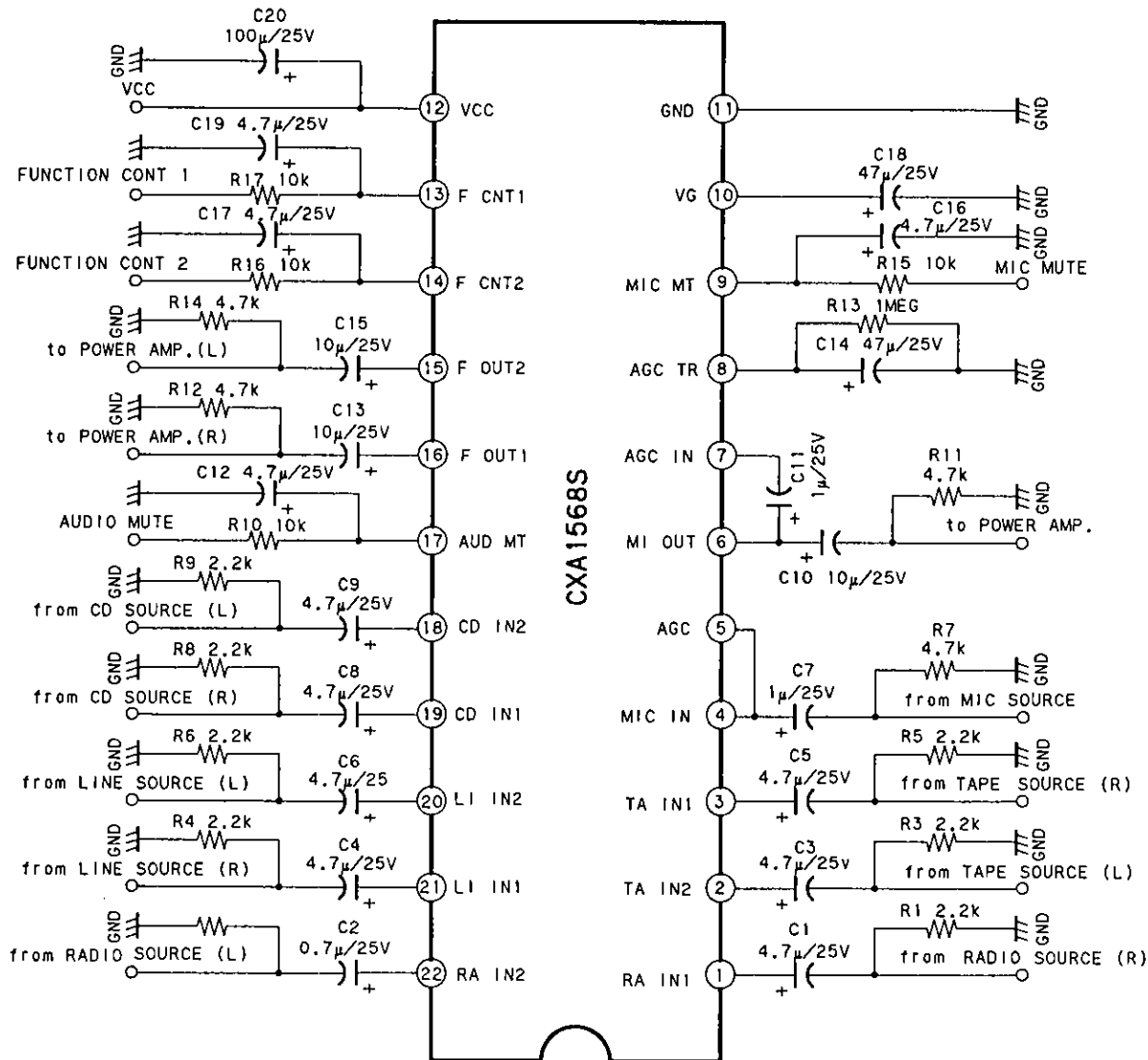

Application circuits shown are typical examples illustrating the operation of the devices. Sony cannot assume responsibility for any problems arising out of the use of these circuits or for any infringement of third party patent and other right due to same.

Description of Operation

1. Function control mode

F CONT1 Pin14 F CONT2 Pin13	L	H
L	TAPE MODE Pins3, 2	RADIO MODE Pins1, 22
H	CD MODE Pins19, 18	LINE IN MODE Pins21, 20

Pins are for 22-pin SDIP.

2. Mute

(1) Audio mute

AUDIO MUTE Pin17	L	H
F OUT1, 2 Pins16, 15	MUTE	Each SOURCE

(2) Microphone mute

MIC MUTE Pin9	L	H
MIC OUT Pin6	MUTE	ON
MIXING (MIC2) ※	MUTE	☆

※ Refer Block Diagram

☆ When the function control mode is TAPE, MUTE is operated. When the remaining RADIO, CD, LINE IN mode, MIXING ON is operated.

Microphone Output Voltage Characteristics

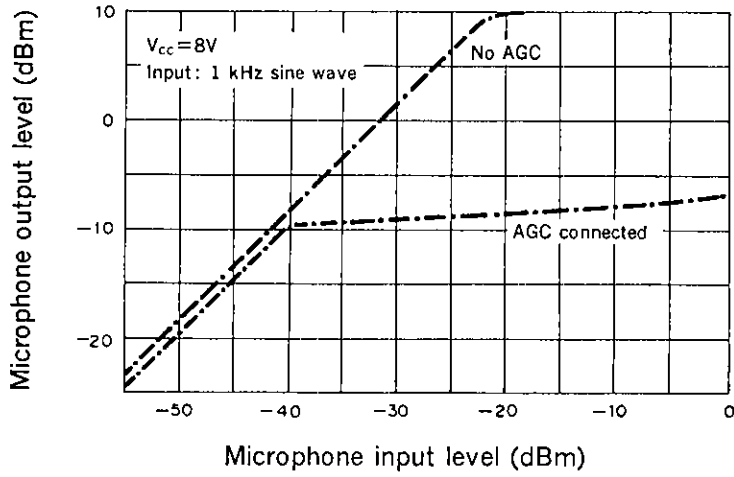

AGC Total Harmonic Distortion Factor

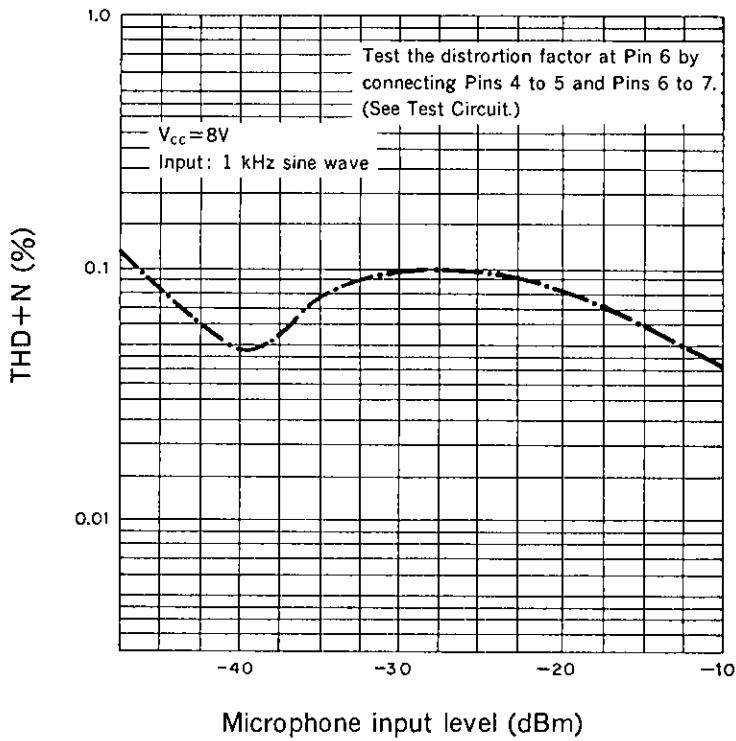

Package Outline Unit : mm

22pin SDIP (Plastic) 300mil

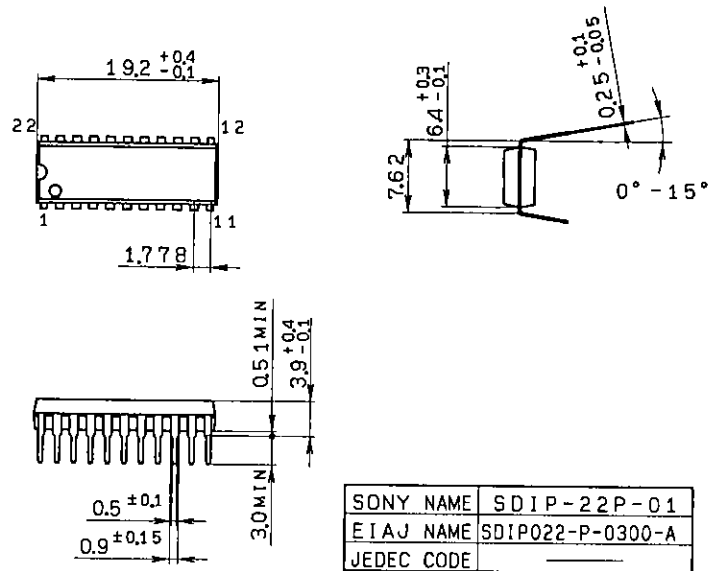

24pin SOP (Plastic) 300mil 0.3g

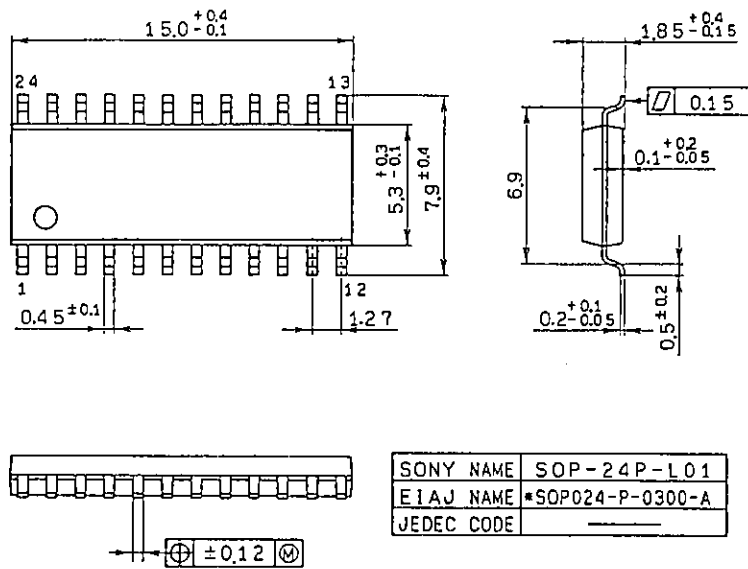

This datasheet has been downloaded from:

www.DatasheetCatalog.com

Datasheets for electronic components.



LittleDiode supplies new, hard to find or obsolete electronic components and semiconductors all over the world.

With over two million different components listed you are sure to find the part you need.

Feel free to visit us today at our online store:

LittleDiode.com

Looking forward to providing you with the best possible service.