

Preamplifier for Remote Control Signal Reception

Description

The CXA1511L/M is a bipolar IC used for preamplifiers that receive signals in infrared remote control systems. These ICs consist of a first-stage amplifier, limiter amplifier, band-pass filter, band elimination filter, signal waveform detection circuit and waveform shaping circuit.

Features

- Low power consumption ($V_{CC} = 5V$, 9mW typ.)
- Low supply voltage ($V_{CC} = 5V$)
- Filters (center frequency can be varied through external resistor: $f_o = 30kHz$ to $60kHz$, 40kHz typ.)
- Elimination of inductors prevents magnetic field inductance interference.
- Optical reception diode can be coupled directly.
- Collector output (pull-up resistor, TTL and CMOS can be connected directly)

Applications

TVs, VCRs, audio equipment

Structure

Bipolar silicon monolithic IC

Block Diagram and Pin Configuration

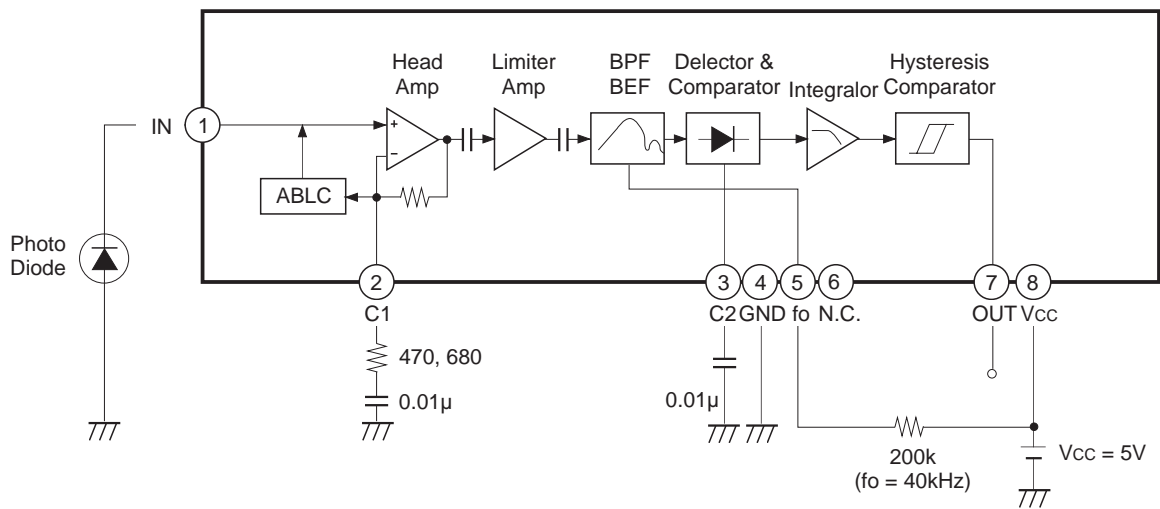

Sony reserves the right to change products and specifications without prior notice. This information does not convey any license by any implication or otherwise under any patents or other right. Application circuits shown, if any, are typical examples illustrating the operation of the devices. Sony cannot assume responsibility for any problems arising out of the use of these circuits.

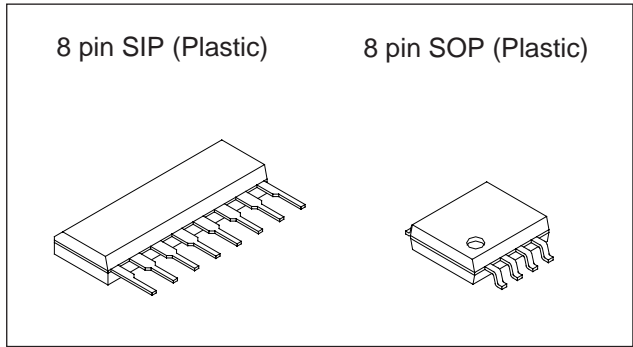

Absolute Maximum Ratings

• Supply voltage	V_{CC}	7	V
• Operating temperature	T_{opr}	-20 to +75	°C
• Storage temperature	T_{stg}	-65 to +150	°C
• Allowable power dissipation	P_D	600	mW (SIP)
• Allowable power dissipation	P_D	300	mW (SOP)

Operating Conditions

• Supply voltage		4.7 to 5.3	V
------------------	--	------------	---

Pin Description

Pin voltage depends on the DC Characteristics Measurement Circuit.

Pin No.	Symbol	Pin voltage	Equivalent circuit	Description
1	IN	2.8V		<p>Input pin. Connect optical reception diode to GND.</p>
2	C1	2.8V		<p>Connect a resistor and capacitor in series to GND, and set the frequency response and gain of "Head Amp". When the resistor is large and the capacitor small, the gain is small. When the capacitor is large, sensitivity decreases in relation to the transient response.</p>
3	C2	1.9V		<p>Connect a detection capacitor to GND. When the capacitor is large, sensitivity decreases in relation to the mean value detection and transient response. When the capacitor is small, fluctuation of the peak detection and output pulse width increases. The capacitor in usage is 0.01µF (typ.). Set output pulse width fluctuation and noise elimination characteristics to be optimum.</p>
4	GND			<p>GND pin. Adopt a pattern design that will allow external parts to be located as closely as possible to this pin. Ground them all at the same point. The transport distance and noise elimination characteristics are greatly influenced by the pattern design surrounding the GND.</p>
5	fo	1.4V		<p>Connect a resistor to the power supply. Set the center frequency of the built-in BPF. See "External resistor at Pin 5 vs. Center frequency response" on Page 6.</p>

Pin No.	Symbol	Pin voltage	Equivalent circuit	Description
6	N.C.			No connected pin. Connect to GND.
7	OUT	5.0V (High) 0.6V (Low)		Output pin.
8	Vcc	5.0V		Supply voltage pin.

DC Characteristics Measurement Circuit
(CXA1511L)

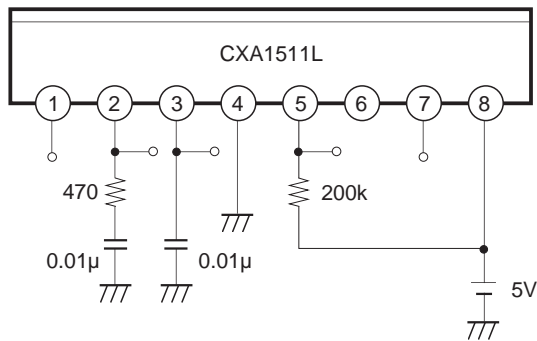

(CXA1511M)

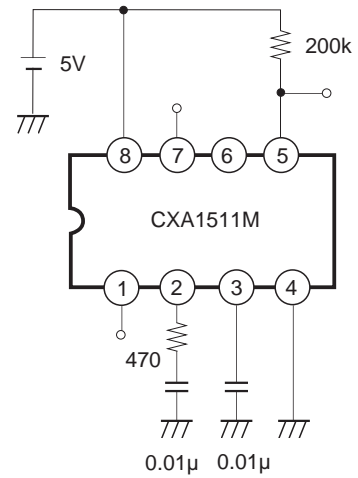

(V_{CC} = 5V, T_a = 25°C)

Electrical Characteristics

No.	Item	Symbol	Measurement condition			Measurement point	Min.	Typ.	Max.	Unit	Remarks
			Signal	Level	ON-SW						
1	Input pin voltage (1)	V _{IN1}			S1, 3, 7	2.3	2.8	3.3	V		
2	Input pin voltage (2)	V _{IN2}			S1, 2, 3, 4, 7	0.6	1.2	1.8	V	100μA is flown out from Pin 1.	
3	L level output voltage	V _{OL}			S3, 7, 8	—	0.6	1.3	V		
4	Voltage gain	A _v	40kHz CW	30μVp-p	S2, 5, 6, 9	75	81	85	dB		
5	BPF characteristics (1)	A _{vO1}	30kHz, 37kHz CW	40μVp-p	S2, 5, 6, 9	5	10	—	dB	Note 1)	
6	BPF characteristics (2)	A _{vO2}	40kHz, 48kHz CW	40μVp-p	S2, 5, 6, 9	5	19	—	dB	Note 2)	
7	Input impedance	r _{in}	40kHz CW	200mVp-p	S1, 2, 6, 7	31	40	64	kΩ	Note 3) Input level is taken V _i and measuring value is taken V _x .	
8	Detecting ability	Det	burst wave	60μVp-p	S2, 5, 6, 7	440	550	770	μs	Burst wave signal with a 1.2ms, 40kHz cycle is input.	
9	Current consumption	I _{CC}			S3, 7	1.0	1.8	2.8	mA		

Note 1) The level ratio between AC level at 37kHz and that at 30kHz is taken A1 [dB]. $A1 = 20 \log \frac{\text{measuring value (f = 37kHz)}}{\text{measuring value (f = 30kHz)}}$

Note 2) The level ratio between AC level at 40kHz and that at 48kHz is taken A2 [dB]. $A2 = 20 \log \frac{\text{measuring value (f = 40kHz)}}{\text{measuring value (f = 48kHz)}}$

Note 3) $r_{in} = \frac{47k\Omega}{(V_i/V_x) - 1}$ [kΩ]

Electrical Characteristics Measurement Circuit

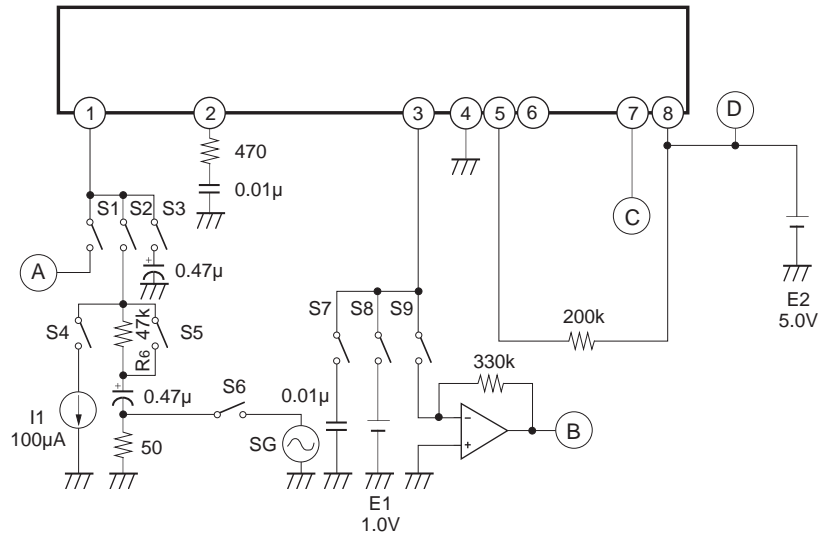

Application Circuit

(CXA1511L)

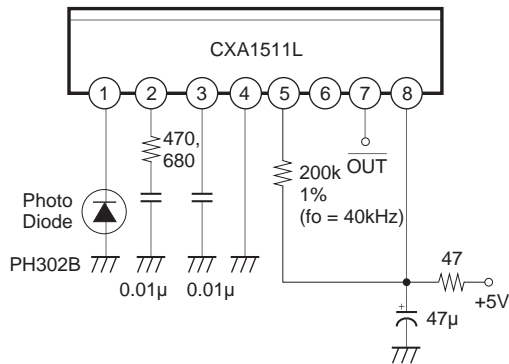

(CXA1511M)

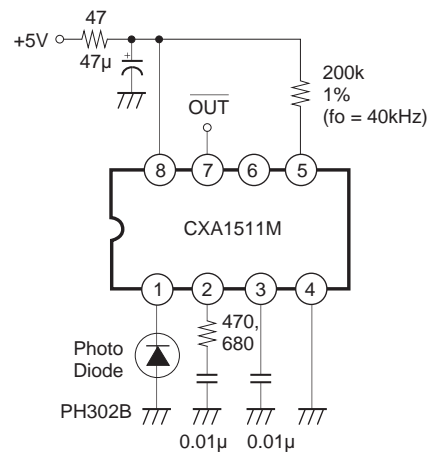

Description of Operation (See the Block Diagram.)

Receives infrared signals transmitted from the infrared remote control commander with a photodiode to output them as rectangular waves.

I/O pin	Waveform	Operation
Pin 1 Input waveform	40µVp-p to 2.5Vp-p 600µs typ. 40kHz (typ.)	Converts the signal current of a photodiode into voltage and amplifies it.
Pin 3 BPF output waveform		Suppresses the noise component with BPF and BEF.
Hysteresis comparator input waveform		Detects the signal component and performs wave detection.
Pin 7 Output waveform	5V 0.6V (typ.)	Integrates the signal component and outputs it as rectangular wave from the hysteresis comparator.

Example of Representative Characteristics

External resistor at Pin 2 vs. Av1 characteristics

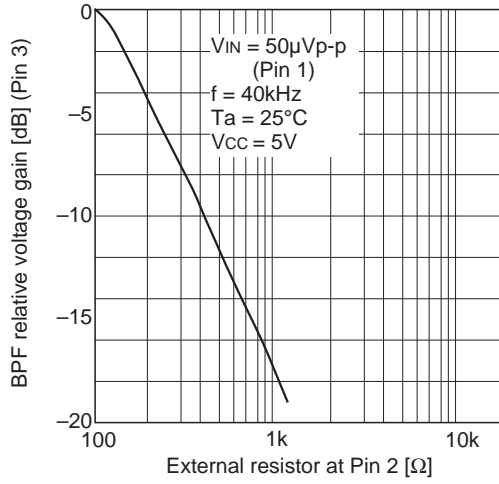

Vcc vs. Icc characteristics

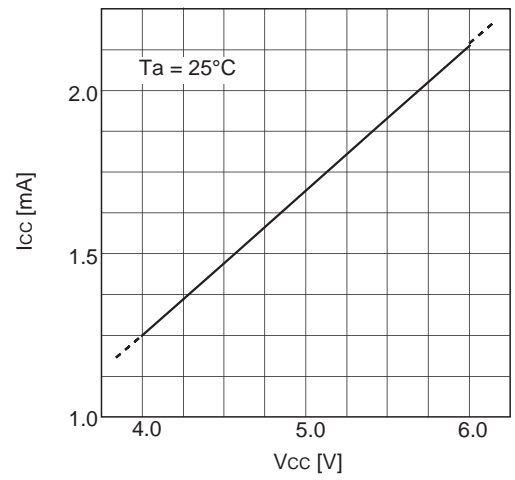

Input voltage at Pin 1 vs. Output voltage at Pin 3 characteristics

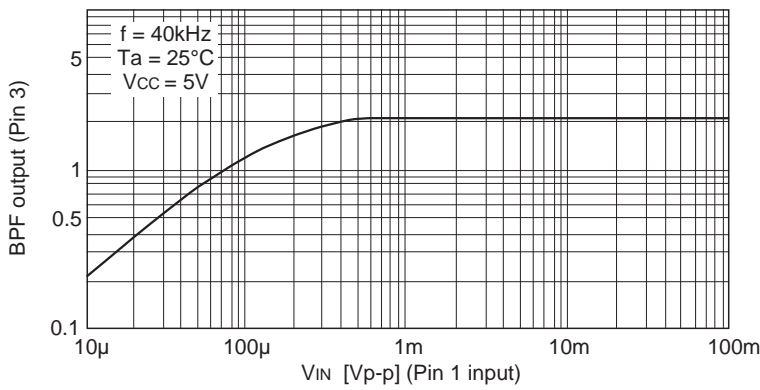

I1 vs. VIN2 characteristics

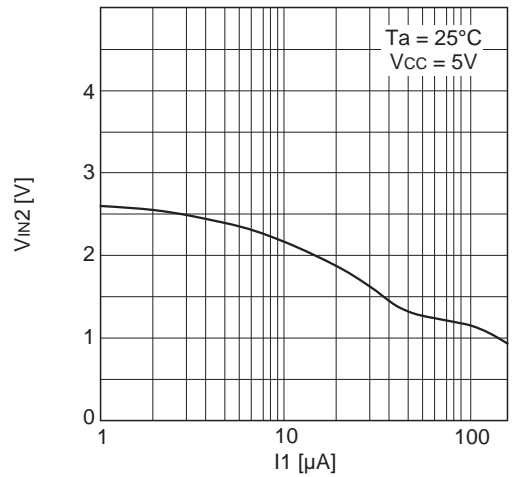

f vs. Av1 characteristics

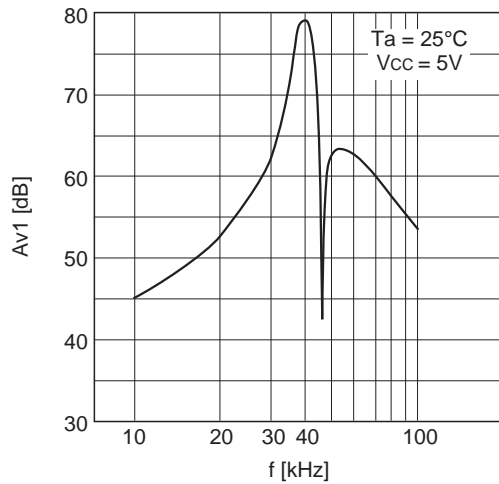

External resistor at Pin 5 vs. Center frequency response

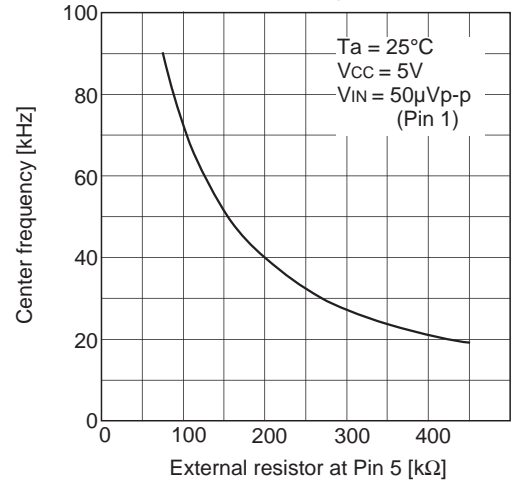

Package Outline

Unit: mm

CXA1511L

8PIN SIP (PLASTIC)

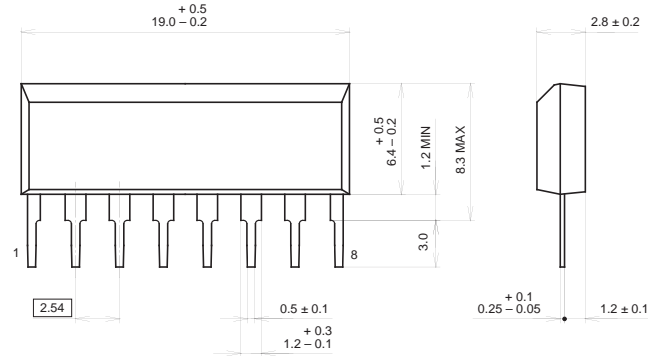

PACKAGE STRUCTURE

SONY CODE	SIP-8P-02
EIAJ CODE	SIP008-P-0340
JEDEC CODE	

PACKAGE MATERIAL	EPOXY RESIN
LEAD TREATMENT	SOLDER PLATING
LEAD MATERIAL	COPPER ALLOY
PACKAGE MASS	0.7g

CXA1511M

8PIN SOP (PLASTIC)

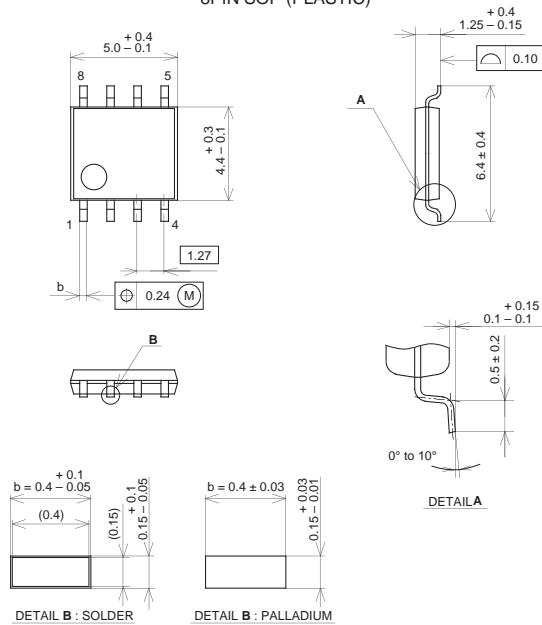

PACKAGE STRUCTURE

SONY CODE	SOP-8P-L03
EIAJ CODE	SOP008-P-0225
JEDEC CODE	

PACKAGE MATERIAL	EPOXY RESIN
LEAD TREATMENT	SOLDER/PALLADIUM PLATING
LEAD MATERIAL	42/COPPER ALLOY
PACKAGE MASS	0.1g

NOTE : PALLADIUM PLATING

This product uses S-PdPPF (Sony Spec.-Palladium Pre-Plated Lead Frame).



LittleDiode supplies new, hard to find or obsolete electronic components and semiconductors all over the world.

With over two million different components listed you are sure to find the part you need.

Feel free to visit us today at our online store:

LittleDiode.com

Looking forward to providing you with the best possible service.