

Recording/Playback Equalizer Amplifier for Stereo Tape Recorder

Description

The CXA1498S/M is a bipolar IC designed as equalizer amplifier for tape recorder recording/playback. This IC is particularly well-suited for double cassette deck applications. An on-chip filter serves to greatly reduce the number of external parts.

Features

- Recording equalizer amplifier × 2
(Monolithic filter eliminates the need for external resonance circuit)
- AGC (automatic gain control) × 2
- Playback equalizer amplifier × 2
(Variable resistor eliminates the need for external feedback resistor)
- Electronic switch for playback head
(Changes between A and B decks)
- Electronic switch for tape equalization
(120μs/70μs) (Independently for A and B decks)
- Electronic switch for metal tapes
- Electronic switch for normal/high speed dubbing
(Effective for both REC EQ and PB EQ)
- Recording mute function
(Soft mute is possible through use of an external time constant circuit)
- DC controllable for fade IN/OUT
(Controls recording mute function)
- Playback mixing output pin provided
(For tune selection)
- Use of this IC simplifies the construction of double cassette dubbing system

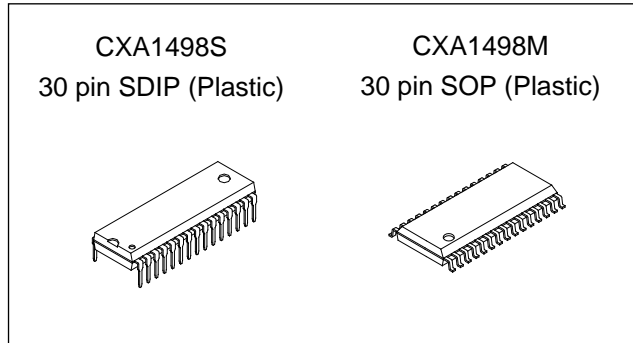

Applications

Recording/playback equalizer amplifier, playback mixing amplifier and AGC for analog stereo tape recorders

Structure

Bipolar silicon monolithic IC

Absolute Maximum Ratings (Ta = 25°C)

• Supply voltage	Vcc	12	V
• Operating temperature	Topr	-20 to +75	°C
• Storage temperature	Tstg	-65 to +150	°C
• Allowable power dissipation	Pd	SDIP 930	mW
		SOP 630	mW

Recommended Operating Condition

Supply voltage	Vcc	4.5 to 10.0	V
----------------	-----	-------------	---

Block Diagram and Pin Configuration (Top View)

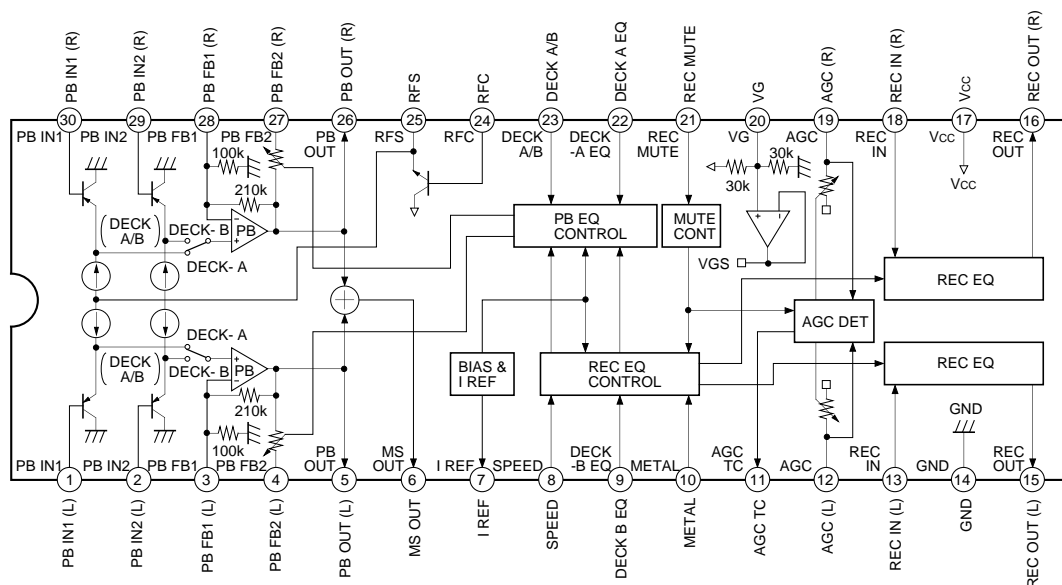

Sony reserves the right to change products and specifications without prior notice. This information does not convey any license by any implication or otherwise under any patents or other right. Application circuits shown, if any, are typical examples illustrating the operation of the devices. Sony cannot assume responsibility for any problems arising out of the use of these circuits.

Pin Description and Equivalent Circuit

(Ta = 25°C, Vcc = 8V, no signal)

Pin No.	Symbol	DC voltage	I/O	I/O resistance	Equivalent circuit	Description
1 2 29 30	PBIN1 L PBIN2 L PBIN2 R PBIN1 R	0V*1	I	—		Playback equalizer amplifier input pins.
3 28	PBFB1 L PBFB1 R	0.8V*1	—	68kΩ		Playback equalizer amplifier negative feedback pins.
5 26	PBOUT L PBOUT R	2.5V*1	O	147Ω		Playback equalizer amplifier output pins.
4 27	PBFB2 L PBFB2 R	2.5V*1	—	—		Connection pins for the capacitor that determines the playback equalizer amplifier's time constant (120μs, 70μs, etc.)
6	MS OUT	2.5V*1	O	147Ω		Mixed output pin for the L and R outputs of the playback equalizer amplifier.

Pin No.	Symbol	DC voltage	I/O	I/O resistance	Equivalent circuit	Description
7	I REF	1.2V	—	—		Recording/playback equalizer reference current setting pin.
8	SPEED	—	I	—		Tape speed switching pin. High: high speed Low: normal speed
9	B EQ					B deck equalizer switching pin. High: 70µs EQ Low: 120µs EQ
10	METAL					B deck metal tape switching pin. High: metal tape Low: normal or CrO ₂ tape
22	A EQ					A deck equalizer switching pin. High: 70µs EQ Low: 120µs EQ
23	DECK AB					A deck/B deck playback switching pin. High: PBIN2 Low: PBIN1
11	AGC TC	0V	—	—		Connection pin for the resistance and capacitor that determines the AGC attack recovery time constant.

Pin No.	Symbol	DC voltage	I/O	I/O resistance	Equivalent circuit	Description
12 19	AGC_L AGC_R	4V	I/O	100kΩ		AGC pins for varying the input resistance according to the input signal level over a range from 100kΩ to several 10Ω.
13 18	RECIN L RECIN R	4V	I	50kΩ		Recording equalizer amplifier input pins.
14	GND	0V	—	—		Ground pin.
15 16	RECOUT L RECOUT R	4V	O	147Ω		Recording equalizer amplifier output pins.
17	Vcc	8V	—	—		Power supply voltage pin.
20	VG	4V	—	15kΩ		Connection pin for the capacitor that eliminates ripple at the signal reference voltage.

Pin No.	Symbol	DC voltage	I/O	I/O resistance	Equivalent circuit	Description
21	MUTE	—	I	—		Recording mute control pin. Permits soft mute by connecting an external CR time constant circuit.
24	RFC	8V*2	—	—		Connection pin for the resistance and capacitor used for generating stable voltage by eliminating ripple from the power supply voltage.
25	RFS	7.2V*2	O	—		Stable voltage output pin.

*1 The values of DC voltage require connection of bias resistance between GND and Pins 1, 2, 29 and 30, respectively.

*2 The values of DC voltage require connection of a resistance between Pin 24 and Vcc, and a capacitor between Pin 24 and GND for eliminating ripple, respectively.

Electrical Characteristics

(Ta = 25°C, Vcc = 8.0V)

Item	Symbol	Conditions*		Min.	Typ.	Max.	Unit	
Operating voltage	Vopr	Single power supply		4.5	8.0	10.0	V	
Current consumption	Icc	NORM/120μs-NORM, No signal		7.0	11.5	15.5	mA	
Recording equalizer amplifier	Reference input level	VIN	NORM-NORM, 315Hz		-34.5	-33.0	-31.5	dBm
	Reference output level	VOUT	NORM-NORM, 315Hz		—	-6.0	—	dBm
	S/N ratio (NORM-NORM)	SN (A-WTG)	Rg = 5kΩ, "A"-WTG filter		60.0	63.5	—	dB
	Signal handling	SH	RL = 2.7kΩ, 1kHz, THD = 1%		8.0	10.0	—	dB
	Total harmonic distortion	THD	RL = 2.7kΩ, 1kHz, 0dB		—	0.19	0.5	%
	Output offset voltage	VOFF	NORM-NORM		3.8	4.13	4.5	V
	NORM-NORM mode frequency characteristics	FNN-1	3kHz, -20dB	For NORM-NORM at 315Hz -20dB	-1.6	-0.4	0.8	dB
		FNN-2	8kHz, -20dB		2.4	3.9	5.4	dB
		FNN-3	12kHz, -20dB		6.4	8.9	11.4	dB
	CrO ₂ -NORM mode frequency characteristics	FCN-1	3kHz, -20dB	For NORM-NORM at 315Hz -20dB	3.4	4.6	5.8	dB
		FCN-2	8kHz, -20dB		6.1	7.6	9.1	dB
		FCN-3	12kHz, -20dB		9.4	11.4	13.4	dB
	METAL-NORM mode frequency characteristics	FMN-1	3kHz, -20dB	For NORM-NORM at 315Hz -20dB	3.2	4.4	5.6	dB
		FMN-2	8kHz, -20dB		5.1	6.6	8.1	dB
		FMN-3	12kHz, -20dB		7.6	9.6	11.6	dB
	NORM-HIGH mode frequency characteristics	FNH-1	5kHz, -20dB	For NORM-NORM at 315Hz -20dB	-1.4	-0.2	1.0	dB
		FNH-2	15kHz, -20dB		3.9	5.7	7.5	dB
		FNH-3	20kHz, -20dB		7.0	9.5	12.0	dB
	CrO ₂ -HIGH mode frequency characteristics	FCH-1	5kHz, -20dB	For NORM-NORM at 315Hz -20dB	3.1	4.3	5.5	dB
		FCH-2	15kHz, -20dB		7.6	9.4	11.2	dB
		FCH-3	20kHz, -20dB		10.3	12.8	15.3	dB
	METAL-HIGH mode frequency characteristics	FMH-1	5kHz, -20dB	For NORM-NORM at 315Hz -20dB	3.7	4.9	6.1	dB
		FMH-2	15kHz, -20dB		7.7	9.2	10.7	dB
FMH-3		20kHz, -20dB	9.8		12.3	14.8	dB	
Recording mute ratio	MT-1	NORM-NORM, 1kHz, +8dB		—	-85.0	-80.0	dB	
Recording mute characteristics	MT-2	NORM-NORM, 1kHz, 2.0V (pin voltage)		-8.0	-6.0	-4.0	dB	
AGC	AGC level	AGC-L	RIN = 10kΩ, 1kHz, -25dBm		-31.0	-29.0	-27.0	dBm
	Channel balance	AGC-B	RIN = 10kΩ, 1kHz, -15dBm		-2.0	0.0	2.0	dB
	AGC distortion	THD-A	RIN = 10kΩ, 1kHz, 0.0dBm		—	0.8	1.5	%

Item	Symbol	Conditions*	Min.	Typ.	Max.	Unit	
Playback equalizer amplifier	120 μ s-NORM mode frequency characteristics	PB-REF	315Hz, -70dBm, Frequency characteristics standard (0dB)	-27.0	-25.0	-23.0	dBm
		F120-N	For 2.7kHz, -58.5dBm, at 315Hz	-1.5	0.0	1.5	dB
	70 μ s-NORM frequency	F70-N	For 4.5kHz, -53.8dBm, at 315Hz	-1.2	0.3	1.8	dB
	120 μ s-HIGH frequency	F120-H	For 5.3kHz, -52.5dBm, at 315Hz	0.7	2.2	3.7	dB
	70 μ s-HIGH frequency	F70-H	For 9.1kHz, -47.8dBm, at 315Hz	1.1	2.6	4.1	dB
	Signal handling	SH	R _L = 2.7k Ω , 1kHz, THD = 1%	-10.0	-3.0	—	dBm
	Total harmonic distortion	THD	R _L = 2.7k Ω , 1kHz, -52dBm	—	0.19	0.5	%
	S/N ratio (120 μ s-NORM)	SN (A-WTG)	R _g = 2.2k Ω , "A"-WTG filter	55.0	60.0	—	dB
	Output offset voltage	VOFF	120 μ s-NORM, R _g = 100k Ω	2.2	2.5	2.8	V
	DC feedback resistance	R _{FB}		150	210	270	k Ω
	Input bias resistance	R _{IN}		—	0.3	1.0	μ A
	MIX output voltage	V-MIX	120 μ s-NORM, 2.7kHz, -52dBm	-1.5	0.0	1.5	dB
	Ripple filter output current	RFIO		10.0	—	—	mA
Control voltage "High" level	VCH	Threshold voltage of mode control pin	2.5	—	V _{CC}	V	
Control voltage "Low" level	VCL	Threshold voltage of mode control pin	GND	—	1.0	V	

* NORM-NORM = NORMAL Tape, NORMAL Speed
 CrO₂-NORM = CrO₂ Tape, NORMAL Speed
 METAL-NORM = METAL Tape, NORMAL Speed
 120 μ s-NORM = EQ: 120 μ s, NORMAL Speed
 70 μ s-NORM = EQ: 70 μ s, NORMAL Speed

NORM-HIGH = NORMAL Tape, HIGH Speed
 CrO₂-HIGH = CrO₂ Tape, HIGH Speed
 METAL-HIGH = METAL Tape, HIGH Speed
 120 μ s-HIGH = EQ: 120 μ s, HIGH Speed
 70 μ s-HIGH = EQ: 70 μ s, HIGH Speed

Electrical Characteristics Test Circuit

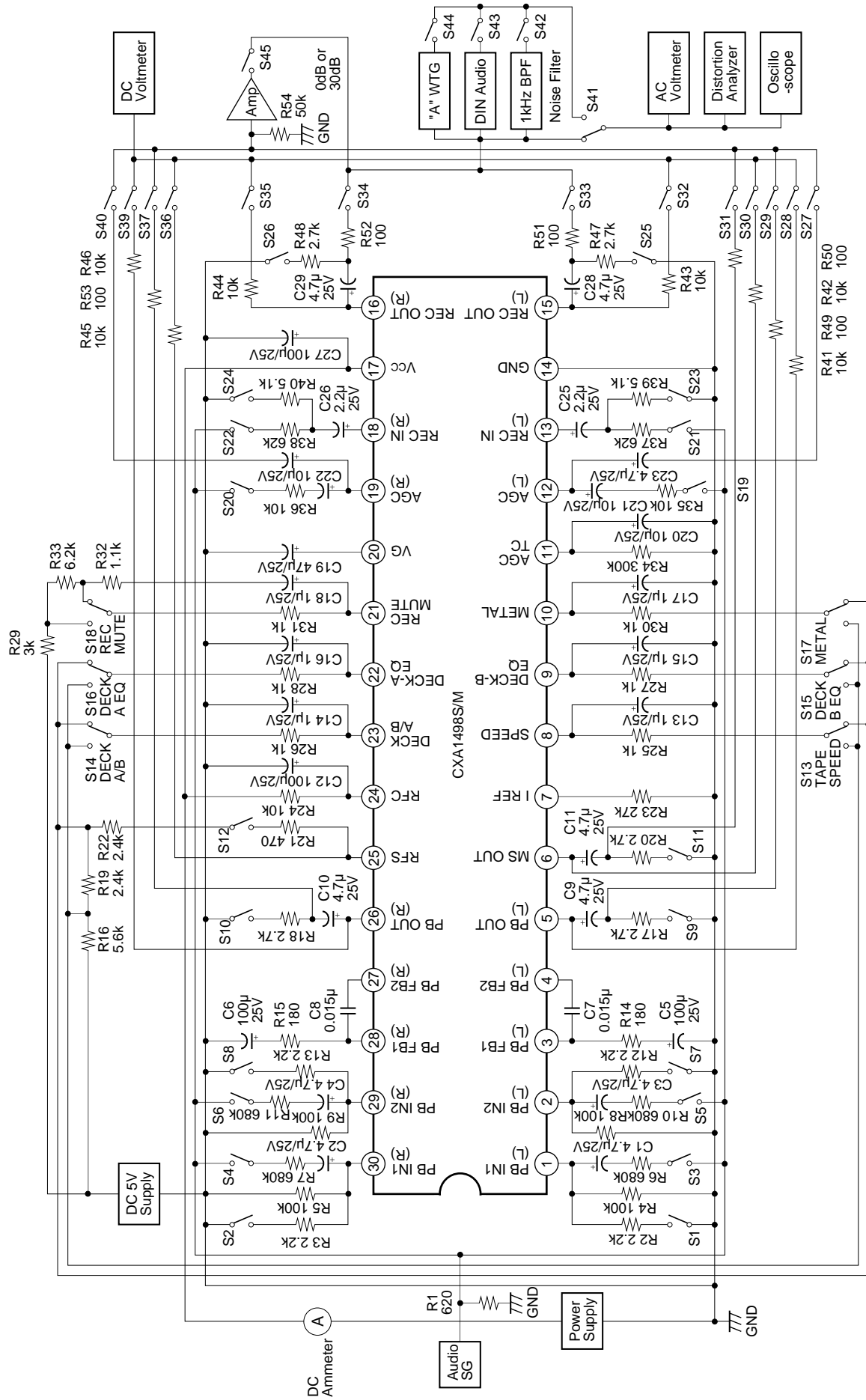

Application Circuit

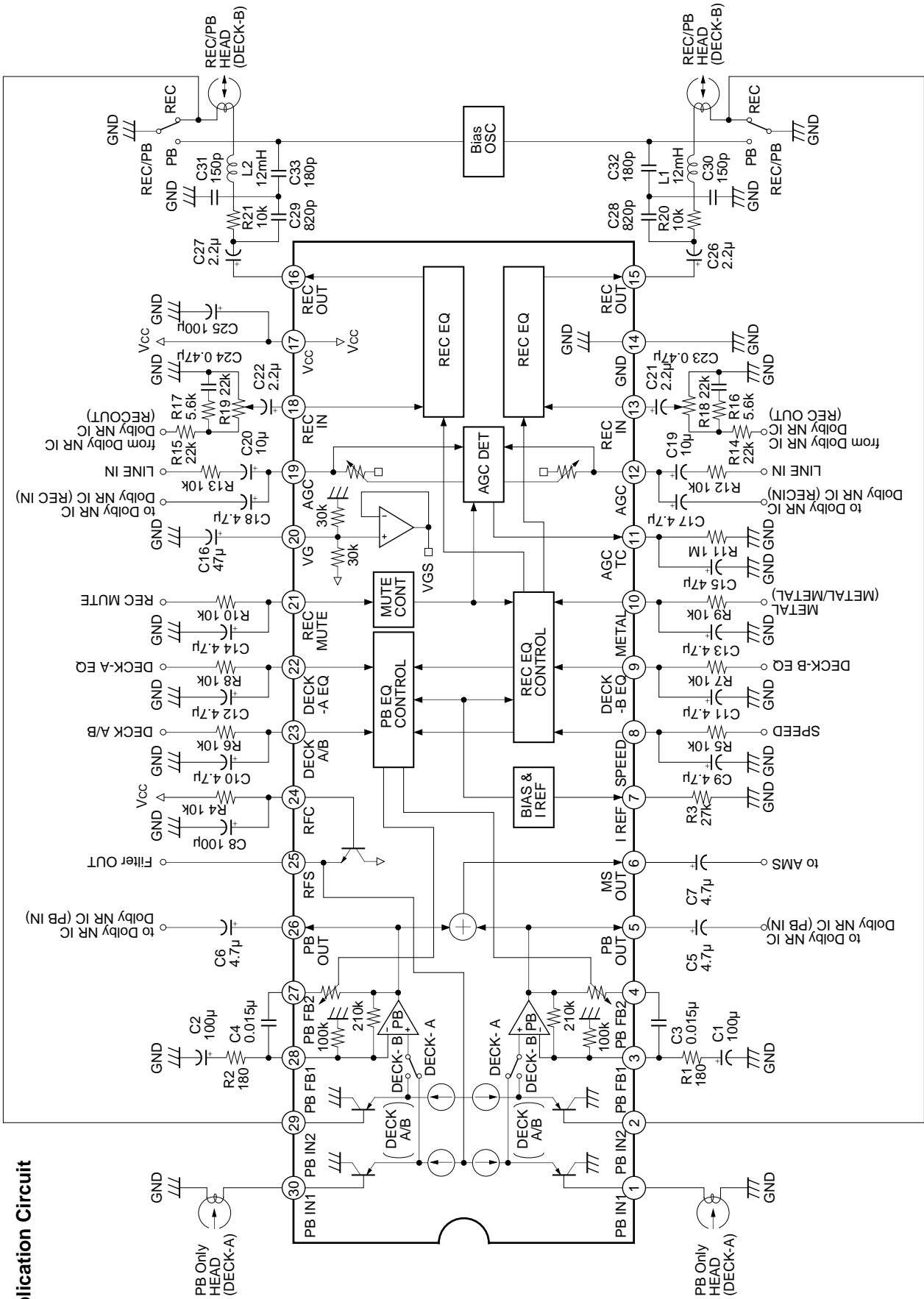

Application circuits shown are typical examples illustrating the operation of the devices. Sony cannot assume responsibility for any problems arising out of the use of these circuits or for any infringement of third party patent and other right due to same.

Notes on Operation

(1) Operation mode control (each mode of recording and playback equalizers)

- 1: Playback equalizer switching (120μs/70μs)
(Pins 9, 22 and 23)

		DECK A-EQ (Pin 22)		DECK B-EQ (Pin 9)	
		L	H	L	H
DECK A/B (Pin 23)	L	120μs (A-DECK)	70μs (A-DECK)	Follows A-EQ control.	
	H	Follows B-EQ control.		120μs (B-DECK)	70μs (B-DECK)

- 2: Normal/double speed switching
(Pin 8)

Both playback and recording equalizers are switched in normal/double speed switching.

SPEED Pin 8	L	H
Playback EQ	Normal speed	Double speed
Recording EQ	Normal speed	Double speed

* For double speed, both playback and recording systems are switched to double speed characteristics of each setting mode:
(PB-EQ: 120μs, 70μs)
(REC-EQ: NORMAL, CrO₂, METAL)

- 3: Recording equalizer switching (NORMAL, CrO₂, METAL)
(Pins 9 and 10)

		METAL (Pin 10)	
		L	H
DECK B-EQ (Pin 9)	L	NORMAL (Type-I)	METAL (Type-IV)
	H	CrO ₂ (Type-II)	METAL (Type-IV)

- (2) Recording mute (REC MUTE: ON/OFF)
(Pin 21)

The recording mute function of the CXA1498S is controlled by a recording mute circuit to vary the electric volume for recording equalizer amplifier gain by applying the DC voltage to REC MUTE (Pin 21).

REC MUTE	Recording mute ON	Attenuation -6dB	Recording mute OFF
Control voltage	GND ≤ VCL ≤ 0.5V	2.0V	3.5V ≤ VCH ≤ Vcc

Recording equalizer vs. Frequency characteristics (Normal speed)

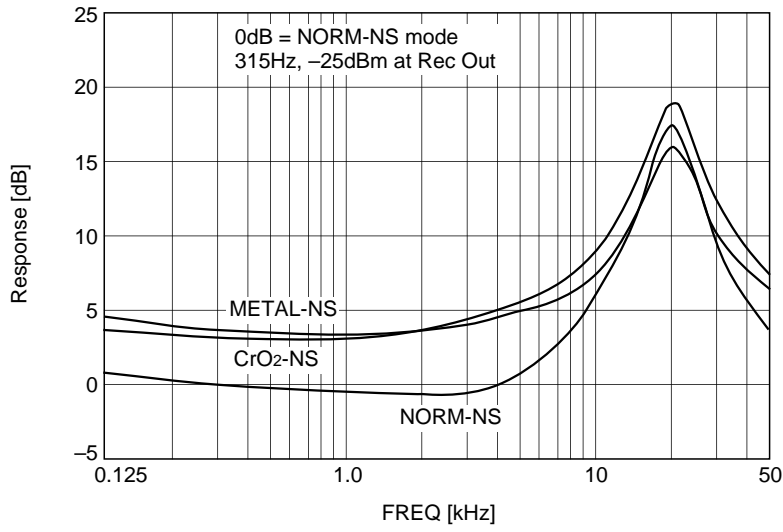

Recording equalizer vs. Frequency characteristics (Double speed)

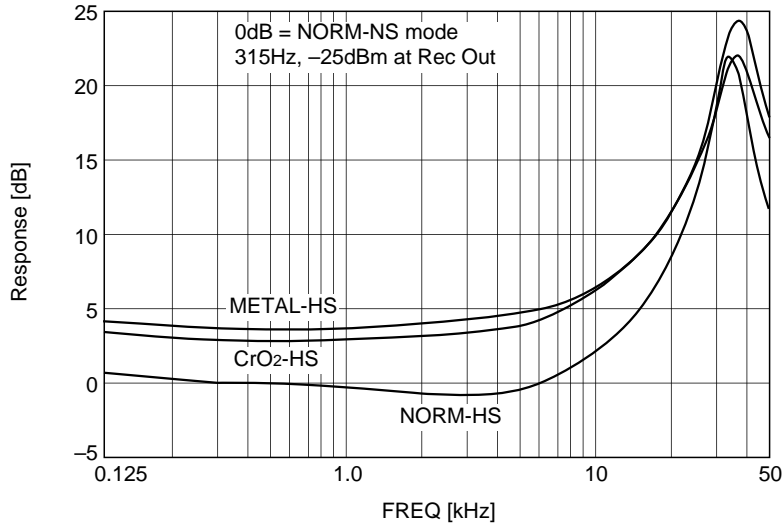

Playback equalizer vs. Frequency characteristics

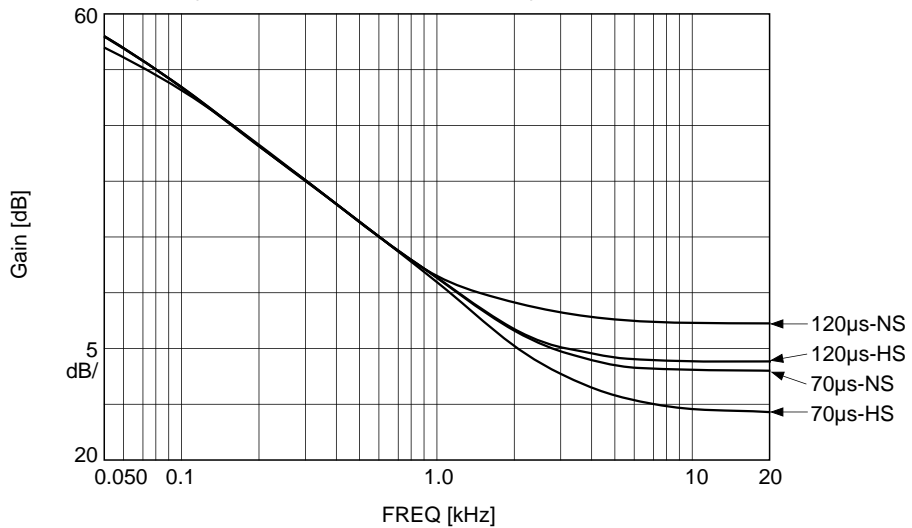

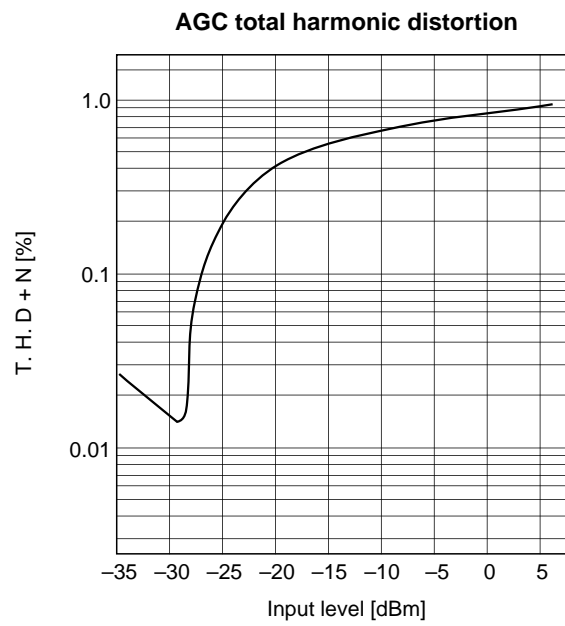
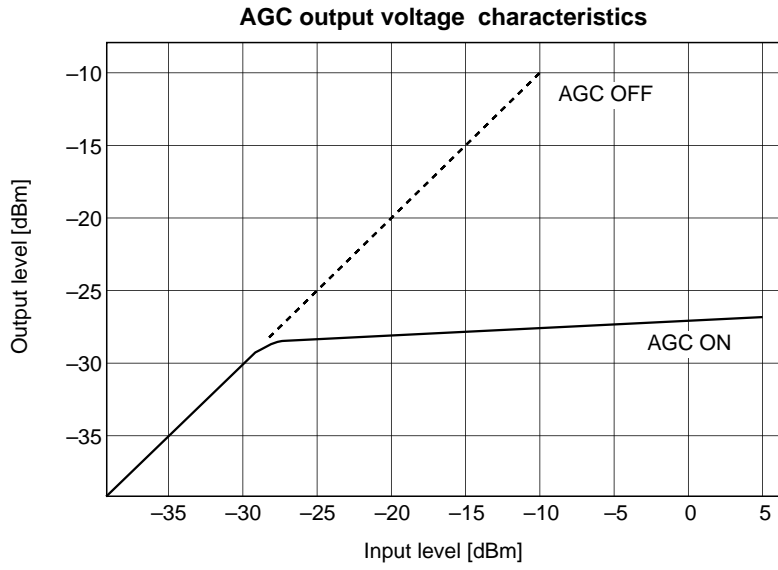

Package Outline

Unit: mm

CXA1498S

30PIN SDIP (PLASTIC) 400mil

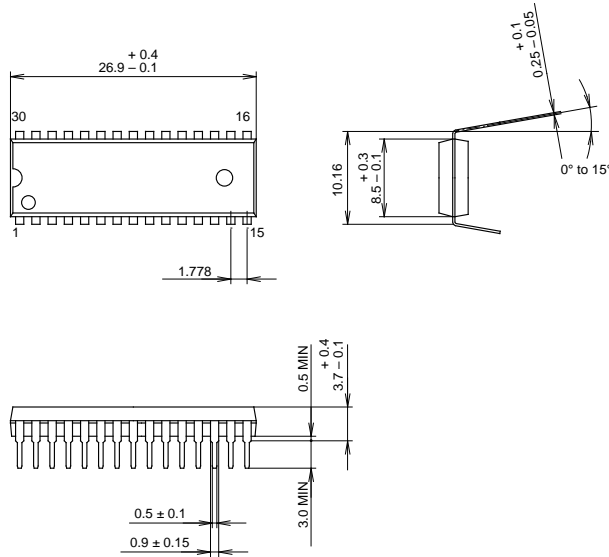

PACKAGE STRUCTURE

SONY CODE	SDIP-30P-01
EIAJ CODE	SDIP030-P-0400-A
JEDEC CODE	_____

MOLDING COMPOUND	EPOXY / PHENOL RESIN
LEAD TREATMENT	SOLDER PLATING
LEAD MATERIAL	COPPER ALLOY
PACKAGE WEIGHT	1.8g

CXA1498M

30PIN SOP (PLASTIC) 375mil

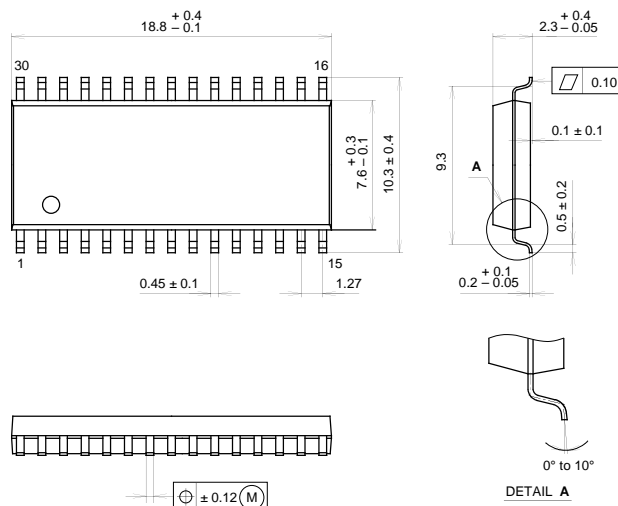

PACKAGE STRUCTURE

SONY CODE	SOP-30P-L03
EIAJ CODE	*SOP030-P-0375-C
JEDEC CODE	_____

PACKAGE MATERIAL	EPOXY RESIN
LEAD TREATMENT	SOLDER PLATING
LEAD MATERIAL	COPPER / 42 ALLOY
PACKAGE WEIGHT	0.7g

This datasheet has been downloaded from:

www.DatasheetCatalog.com

Datasheets for electronic components.



LittleDiode supplies new, hard to find or obsolete electronic components and semiconductors all over the world.

With over two million different components listed you are sure to find the part you need.

Feel free to visit us today at our online store:

LittleDiode.com

Looking forward to providing you with the best possible service.