

Low Current Consumption FM IF Amplifier for Pagers

Description

The CXA1474M/N is a low current consumption FM IF amplifiers which employ the newest bipolar process. It is suitable for such sets as Japan single conversion pagers which require low current consumption.

Features

- Low current consumption 920 μ A (typ. at $V_{cc}=1.5V$)
- Low voltage operation $V_{cc}=1.0$ to $4.0V$
- Few external parts for needless of IF decoupling capacitor
- Built-in reference power supply for operational amplifier and comparator
- Small package 16-pin VSOP

Functions

- Second IF and limiter amplifiers
- FM detector
- Quaternary LPF operational amplifier
- FSK comparator
- Regulator output for RF amplifier and first mixer
- Power-save function
- Low voltage detection circuit

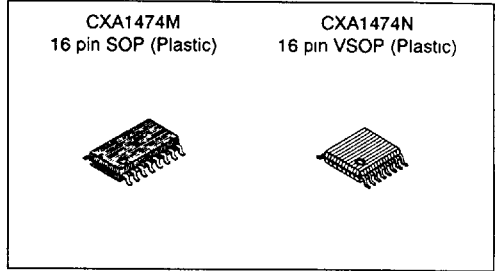

Applications

Single super pagers for Japan and overseas

Absolute Maximum Ratings ($T_a=25^\circ C$)

| | | | |
|-------------------------|-----------|-------------|------------|
| • Supply voltage | V_{cc} | 12.0 | V |
| • Operating temperature | T_{opr} | -20 to +75 | $^\circ C$ |
| • Storage temperature | T_{stg} | -65 to +150 | $^\circ C$ |

Operating Condition

| | | | |
|----------------|----------|------------|---|
| Supply voltage | V_{cc} | 1.0 to 4.0 | V |
|----------------|----------|------------|---|

3

Block Diagram

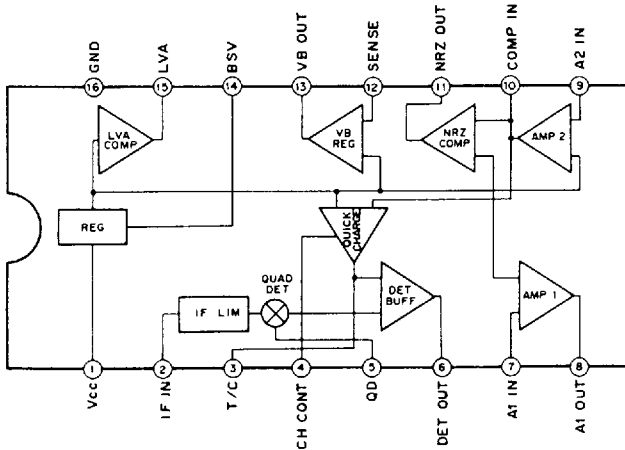

Pin Description

| Pin No | Symbol | Pin voltage | Equivalent circuit | Description |
|--------|---------|-------------|--------------------|---|
| 1 | Vcc | | | Vcc |
| 2 | IF IN | 1.5V | | IF limiter amplifier input. |
| 3 | T/C | 0.2V | | Connects a capacitor that determines the low cut-off frequency for the entire system. |
| 4 | CH CONT | 0V | | Controls the ON/OFF operation of the quick-charge circuit. (Input voltage range: -0.5 to +7.0V) |
| 5 | QD | 1.5V | | Connects to the phase shifter of FM detector circuit. |

| Pin No. | Symbol | Pin voltage | Equivalent circuit | Description |
|---------|----------------|--------------|--------------------|--|
| 6 | DET OUT | 0.2V | | FM detector output. |
| 7 9 | A1 IN A2 IN | 0.2V 0.2V | | Input for operational amplifier 1 and 2 (AMP1, AMP2). |
| 8 | A1 OUT | 0.2V | | Output for operational amplifier 1 (AMP1). |
| 10 | COMP IN | 0.2V | | NRZ comparator input. Output for operational amplifier 2 (AMP2) is output. |

3

| Pin No. | Symbol | Pin voltage | Equivalent circuit | Description |
|----------|--------------------|-------------|--------------------|--|
| 11 15 | NRZ OUT LVA OUT | — — | | NRZ and LVA comparator outputs and are open collectors. (Applied voltage range) (-0.5 to +7.0V) |
| 12 | SENSE | 0.2V | | Input pin for internal constant-voltage source amplifier. This pin is controlled to maintain 200mV. |
| 13 | VB OUT | — | | Output pin for internal constant-voltage source amplifier. Connect the base of PNP transistor. (Current capacity: 200 μA) |
| 14 | BSV | — | | Controls battery saving. Setting this pin low suspends the operation of IC. (Input voltage range: -0.5 to +7.0V) |
| 16 | GND | — | | GND |

Electrical Characteristics ($V_{CC}=1.5V$, $T_a=25^\circ C$, $F_s=455kHz$, $F_{MOD}=256Hz$, $F_{DEV}=2.3kHz$, $AM_{MOD}=30\%$)

| Item | Symbol | Conditions | Min. | Typ. | Max. | Unit |
|----------------------------------|----------------------|---|------|------|------|------------------|
| Current consumption | I _{CC} | Test circuit 1 | 700 | 920 | 1200 | μA |
| Current consumption | I _{CCS} | Test circuit 1, V _I =0.3V | | | 20 | μA |
| AM rejection ratio | AMRR | Test circuit 3, V _{IN} =60dBμ | 25 | | | dB |
| Op amp. input bias current | I _{BIAS} | Test circuit 2 | | 40 | 100 | nA |
| Op amp. open loop gain | A _V | Test circuit 4 | 45 | 60 | | dB |
| Op amp. output voltage amplitude | V _O | Test circuit 5 | 0.65 | | | V _{p-p} |
| NRZ output saturation voltage | V _{SATNRZ} | Test circuit 8 | | | 0.4 | V |
| NRZ output leak current | I _{LNZR} | Test circuit 7 | | | 5.0 | μA |
| NRZ hysteresis width | V _{TWNRZ} | Test circuit 6 | 5 | 10 | 17 | mV |
| VB output current | I _{OUT} | — | | | 200 | μA |
| VB output saturation voltage | V _{SATVB} | Test circuit 9 | | | 0.4 | V |
| VB SENSE voltage | V _{SENVB} | — | 205 | 215 | 225 | mV |
| LVA operating voltage | V _{LVA} | Test circuit 10 | 1.10 | 1.15 | 1.20 | V |
| LVA hysteresis | V _{THLVA} | Test circuit 10 | 10 | 50 | 100 | mV |
| LVA output leak current | I _{LLVA} | Test circuit 10 | | | 5.0 | μA |
| LVA output saturation voltage | V _{SATLVA} | Test circuit 8 | | | 0.4 | V |
| Detector output voltage | V _{ODET} | Test circuit 3 | 16 | 20 | 28 | mV |
| Logic input voltage high level | V _{THBSV} | | 0.9 | | | V |
| Logic input voltage low level | V _{TLBSV} | | | | 0.35 | V |
| Limiting sensitivity | V _{IN(LIM)} | Test circuit 3 | | 17 | 24 | dBμ |

Design Data

| Item | Symbol | Conditions | Min. | Typ. | Max. | Unit |
|----------------------------------|---------------------|-----------------------|------|------|------|------|
| IF limiter input resistance | R _{INLIM} | | 1.6 | 2.0 | 2.4 | kΩ |
| IF limiter gain stability | G _{SLIM} | | -6 | | +6 | dB |
| DET OUT output resistance | R _{OUTDET} | | | | 200 | Ω |
| Op amp. maximum input voltage | | V _{CC} =1.1V | 0.39 | | | V |
| Op amp. minimum input voltage | | | | | 0.05 | V |
| Comparator maximum input voltage | | V _{CC} =1.1V | 0.39 | | | V |
| Comparator minimum input voltage | | | | | 0.05 | V |
| Op amp. offset voltage | | | | | 3.0 | mV |

Test Circuit

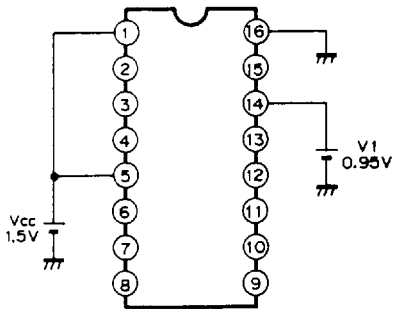

Test circuit 1

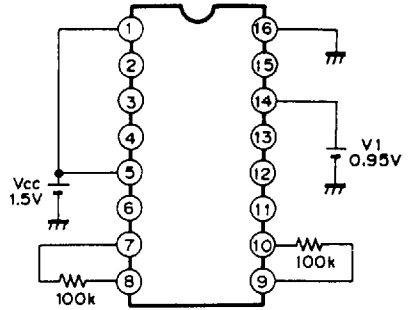

Test circuit 2

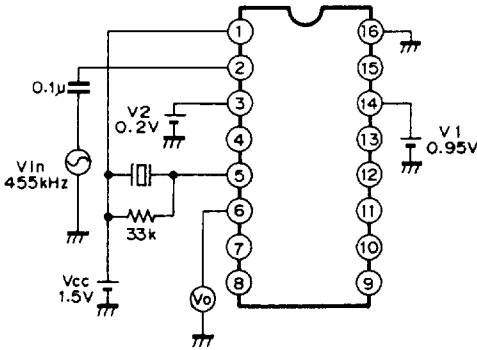

Test circuit 3

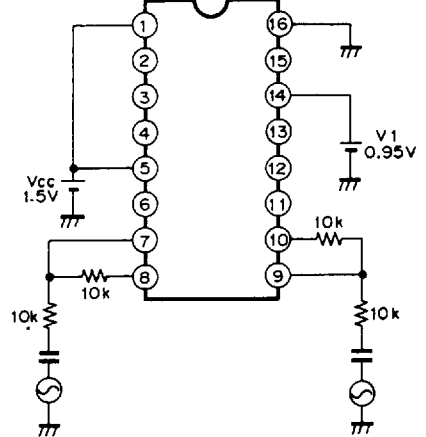

Test circuit 4

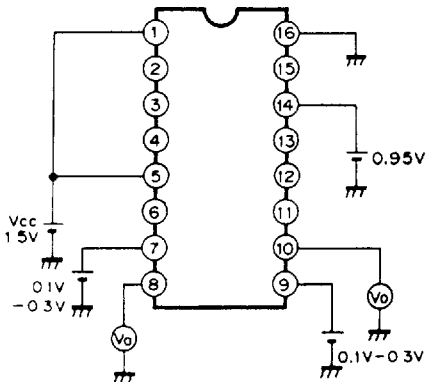

Test circuit 5

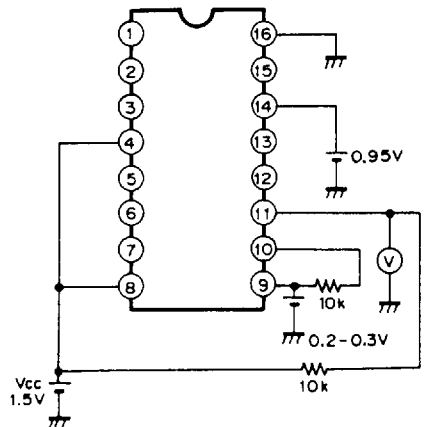

Test circuit 6

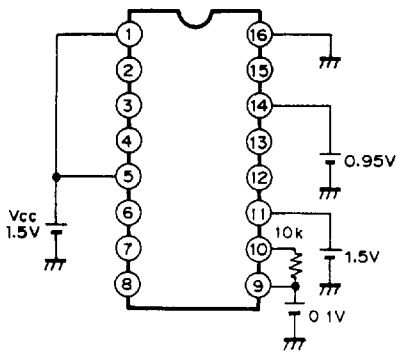

Test circuit 7

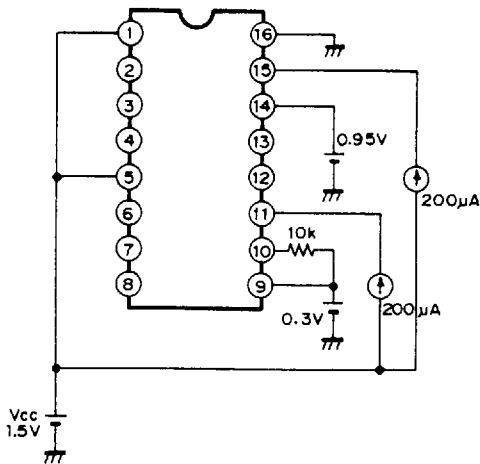

Test circuit 8

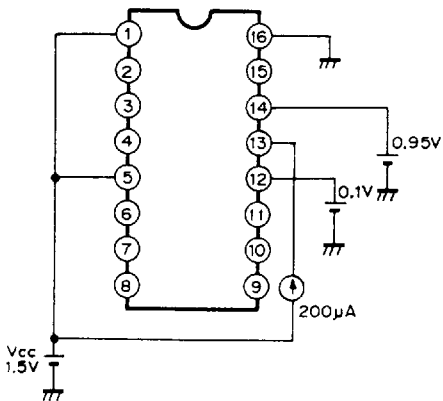

Test circuit 9

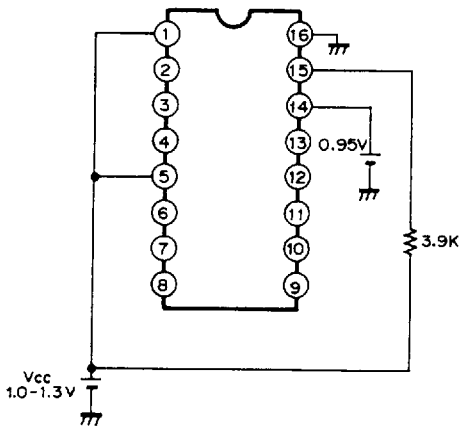

Test circuit 10

3

1) Power Supply

The CXA1474M/N, with built-in regulator, is designed to permit stable operation at wide range of supply voltage from 1.0 to 4.0V. Decouple the wiring to Vcc (Pin 1) as close to the pin as possible.

2) IF Filter

The filter to be connected between IF limiters should have the following specifications.

- Input impedance : $2.0k\Omega \pm 10\%$
- Band width : Changes according to applications

3) IF Limiter Amplifier

The gain of this IF limiter amplifier is approximately 100dB so that, note that the following points about wiring to the IF limiter amplifier input pin (Pin 2).

- a) Be sure to wire to the IF limiter amplifier input (Pin 2) as short as possible.
- b) As the IF limiter amplifier output appears at QD (Pin 5), be sure to wire to the RLC and ceramic discriminator connected to QD as short as possible and reduce the interference on the mixer output and IF limiter amp input.

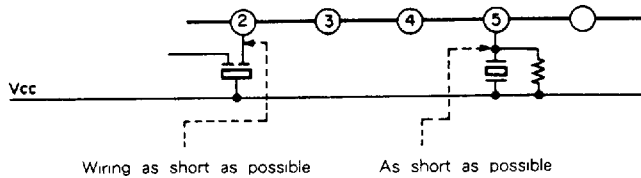

Fig. 1

4) Quick Charge

In order to hasten the rising time from when power is turned on or when reception standby, the CXA1474M/N features a quick charge circuit.

Therefore, the quick charge circuit eliminates the need to insert capacitor between the detector output and the LPF as is the case with conventional ICs, but connects capacitor to Pin 3 to determine the average signal level during steady-state reception.

Connect a signal for controlling the quick charge circuit to Pin 4. Setting this pin high enables the quick charge mode, setting this pin low enables the steady-state reception mode.

Connect Pin 4 to GND when quick charge is not being used.

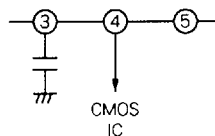

5) Detector

The detector is a quadrature type. To perform phase shift, connect RLC resonator circuit or ceramic discriminator to Pin 5.

The phase shifting capacitor for the quadrature detector is built in.

This detector attenuates the high frequency components of the demodulated FM (FSK) signal with the internal CR-constructed LPF, and outputs it to DET OUT (Pin 6).

DET OUT output impedance is 200Ω or less.

The CDBM455C25 (MURATA MFG. CO., LTD.) ceramic discriminator for the CXA1474M is recommended.

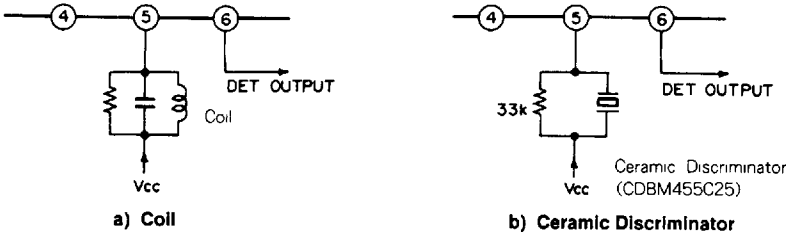

Fig. 3

6) AMP, NRZ OUT

Two operational amplifiers are built in this IC.

One of them is connected internally to an NRZ comparator.

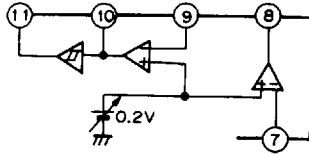

Fig. 4

Using these two operational amplifiers to construct an LPF, remove noise from the demodulated signal and input to the NRZ comparator, which is the next stage.

The NRZ comparator molds waveform of this input signal and outputs it as a square wave. The NRZ comparator output stage is for open collector.

Thus, if the CPU is a CMOS-type and the supply voltage is different, a direct interface as illustrated in the figure below can be implemented.

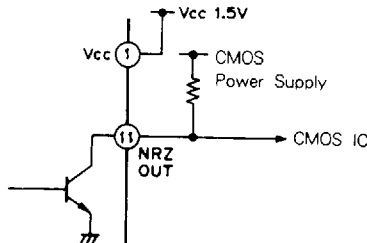

Fig. 5

7) VB SENSE, VB OUT

Controls the base bias of the external transistors.

8) LVA OUT

This pin goes high (open) when the supply voltage becomes low. Since the output is an open collector, it can be used to directly drive CMOS device as can NRZ OUT. The setting voltage of the LVA is 1.15V (typ.), and it possesses a hysteresis with respect to the supply voltage. The hysteresis width is 50mV (typ.).

9) BSV

Operation of the CXA1474M/N can be halted by setting this pin low. This pin also can be connected directly to CMOS device. Also, the current consumption for BSV is 20 μ A or less (at 1.5V).

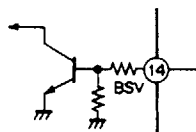

Fig. 6

Principle of Quick Charge Operation

BUF in Fig. 7 is the detector buffer amplifier, and AMP1 and AMP2 are operational amplifiers to construct LPF. COMP is the NRZ comparator. Coupling on conventional system is performed by placing a capacitor between the detector buffer and the LPF operational amplifier, matching of DC is not performed. Thus, this matching capacitor must be charged when restoring the system from reception standby mode to reception mode, within which time signals from the comparator appear at the NRZ output.

To shorten this rise time, as shown in Fig. 7 the CXA1474 adds feedback loop from the comparator input to the input circuit of output. This equalizes the average value of the comparator input voltage to the reference voltage, with the quick charge circuit of CHG being set inside the feedback loop. Switching the current of quick change circuit enables reduction of the rise time.

In this block, CHG is comparator which compares the input voltage and outputs current based on this comparison. The current on CHG is switched between high and low at Pin 4. To shorten the time constant when switching from reception standby mode to reception mode, switch the current to high and increase the charge current at C in Fig. 7. During steady-state reception mode, switch the current to low, lengthening the charge time constant, and allowing for stable data retrieval.

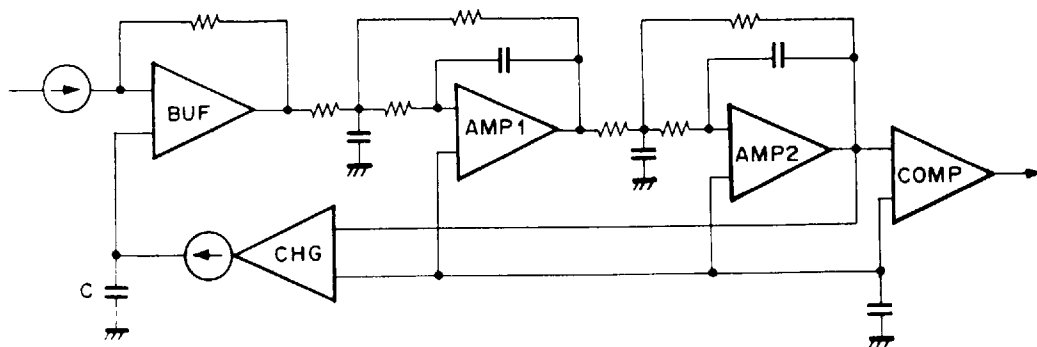
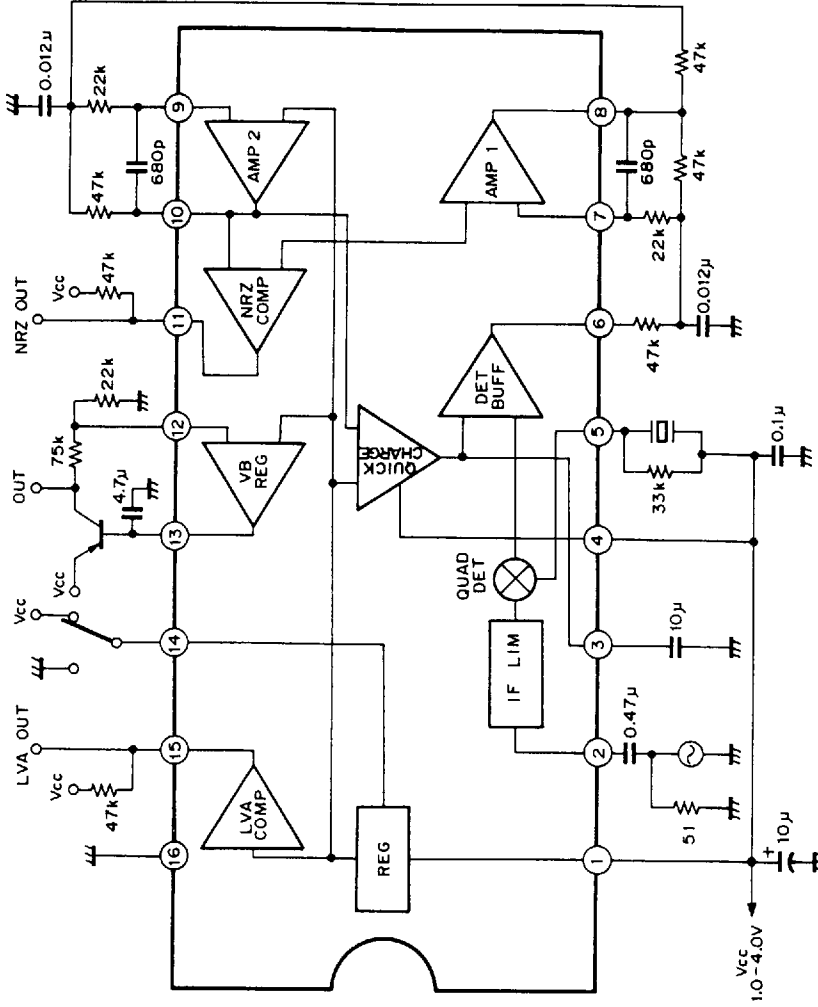

Fig. 7

Application Circuit



Application circuits shown are typical examples illustrating the operation of the devices. Sony cannot assume responsibility for any problems arising out of the use of these circuits or for any infringement of third party patent and other right due to same.



Example of Representative Characteristics

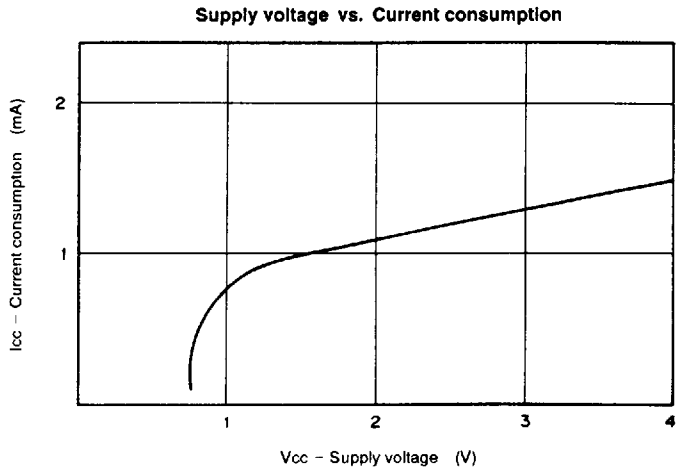
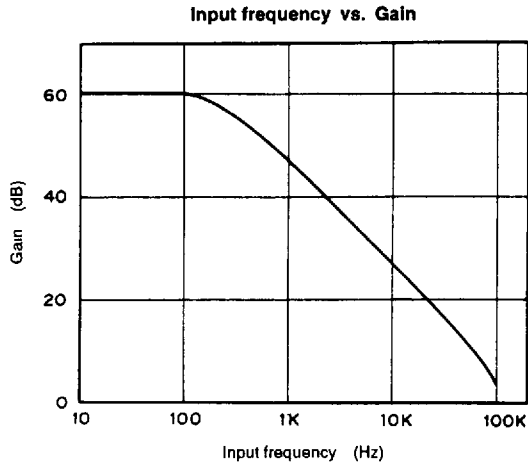

Package Outline Unit : mm

CXA1474M 16pin SOP (Plastic) 300mil 0.2g

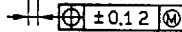
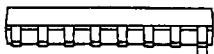
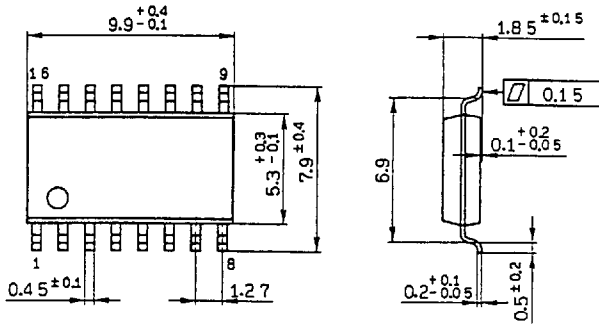

| | |
|------------|------------------|
| SONY NAME | SOP-16P-L01 |
| EIAJ NAME | *SOP016-P-0300-A |
| JEDEC CODE | |

CXA1474N 16pin VSOP (Plastic) 225mil

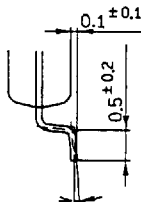
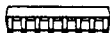
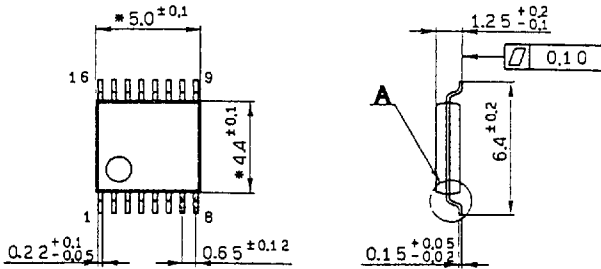

| | |
|------------|------------------|
| SONY NAME | VSOP-16P-L01 |
| EIAJ NAME | SSOP016-P-0225-A |
| JEDEC CODE | |















*(Similar)

Detailed diagram of A $0^\circ - 10^\circ$

Note) Dimensions marked with * does not include resin residue.

3

Package Name

| Type | Package name | | Package | Features | | | | | |
|-----------------------|-----------------|-----------------------------------|--------------------------------|---|--|------------------------------------|--------------------------|--------------------|-------------|
| | Symbol | Description | | Material | Lead pitch | Lead shape | Lead pull out direction | | |
| Inserted | Standard | D I P | DUAL IN-LINE PACKAGE |  | P C | 2.54mm (100MIL) | Through Hole Lead | 2-direction | |
| | | S I P | SINGLE IN LINE PACKAGE |  | P | 2.54mm (100MIL) | Through Hole Lead | 1-direction | |
| | | Z I P | ZIG ZAG IN-LINE PACKAGE |  | P | 2.54mm (100MIL) Zig-Zag in-line | Through Hole Lead | 1-direction | |
| | | P G A | PIN GRID ARRAY |  | C | 2.54mm (100MIL) | Through Hole Lead | Package under side | |
| | | PIGGY BACK | PIGGY BACK |  | C | 2.54mm (100MIL) | Through Hole Lead | 2-direction | |
| | Shrink | SDIP | SHRINK DUAL IN-LINE PACKAGE |  | P | 1.778mm (70MIL) | Through Hole Lead | 2-direction | |
| | | SZIP | SHRINK ZIG-ZAG IN-LINE PACKAGE |  | P | 1.778mm (70MIL) Zig-Zag in-line | Through Hole Lead | 1-direction | |
| | Surface mounted | Standard flat package | Q F P | QUAD FLAT L LEADED PACKAGE |  | P C | 1.0mm 0.8mm 0.65mm | Gull-Wing | 4-direction |
| | | | S O P | SMALL OUTLINE L-LEADED PACKAGE |  | P | 1.27mm (50MIL) | Gull-Wing | 2-direction |
| | | Standard 2-direction chip carrier | S O J | SMALL OUTLINE J-LEADED PACKAGE |  | P | 1.27mm (50MIL) | J-Lead | 2-direction |
| Shrink flat package | | VQFP | VERY SMALL QUAD FLAT PACKAGE |  | P | 0.5mm | Gull-Wing | 4-direction | |
| | | VSOP | VERY SMALL OUTLINE PACKAGE |  | P | 0.65mm | Gull-Wing | 2-direction | |
| | | TSOP | THIN SMALL OUTLINE PACKAGE |  | P | 0.5mm (0.55mm) | Gull-Wing | 2-direction | |
| Standard chip carrier | | Q F J | QUAD FLAT J-LEADED PACKAGE |  | P | 1.27mm (50MIL) | J-Lead | 4-direction | |
| | | Q F N | QUAD FLAT NON-LEADED PACKAGE |  | C | 1.27mm (50MIL) | Leadless | Package under side | |

* PPlastic, CCeramic

2

This datasheet has been downloaded from:

www.DatasheetCatalog.com

Datasheets for electronic components.



LittleDiode supplies new, hard to find or obsolete electronic components and semiconductors all over the world.

With over two million different components listed you are sure to find the part you need.

Feel free to visit us today at our online store:

LittleDiode.com

Looking forward to providing you with the best possible service.