

Absolute Maximum Ratings ($T_a = 25^\circ\text{C}$)

• Supply voltage	A_{VEE}, D_{VEE}	-7 to +0.5	V
• Analog input voltage	V_{IN}	-2.7 to +0.5	V
• Reference input voltage	V_{RT}, V_{RB}, V_{RM}	-2.7 to +0.5	V
	$ V_{RT} - V_{RB} $	2.5	V
• Digital input voltage	$CLK, \overline{CLK}, MINV, LINV$	-4 to +0.5	V
	$ CLK - \overline{CLK} $	2.7	V
• V_{RM} pin input current	I_{VRM}	-3 to +3	mA
• Digital output current	ID_0 to ID_7	-30 to 0	mA
• Storage temperature	T_{stg}	-65 to +150	$^\circ\text{C}$

Recommended Operating Conditions

		Min.	Typ.	Max.	unit
• Supply voltage	A_{VEE}, D_{VEE}	-5.5	-5.2	-4.95	V
	$A_{VEE} - D_{VEE}$	-0.05	0	+0.05	V
	$AGND - DGND$	-0.05	0	+0.05	V
• Reference input voltage	V_{RT}	-0.1	0	+0.1	V
	V_{RB}	-2.2	-2.0	-1.8	V
• Analog input voltage	V_{IN}	V_{RB}		V_{RT}	
• Pulse width of clock	TPW_1	4.0			ns
	TPW_0	4.0			ns
• Operating temperature	T_a	-20		+75	$^\circ\text{C}$

Block Diagram

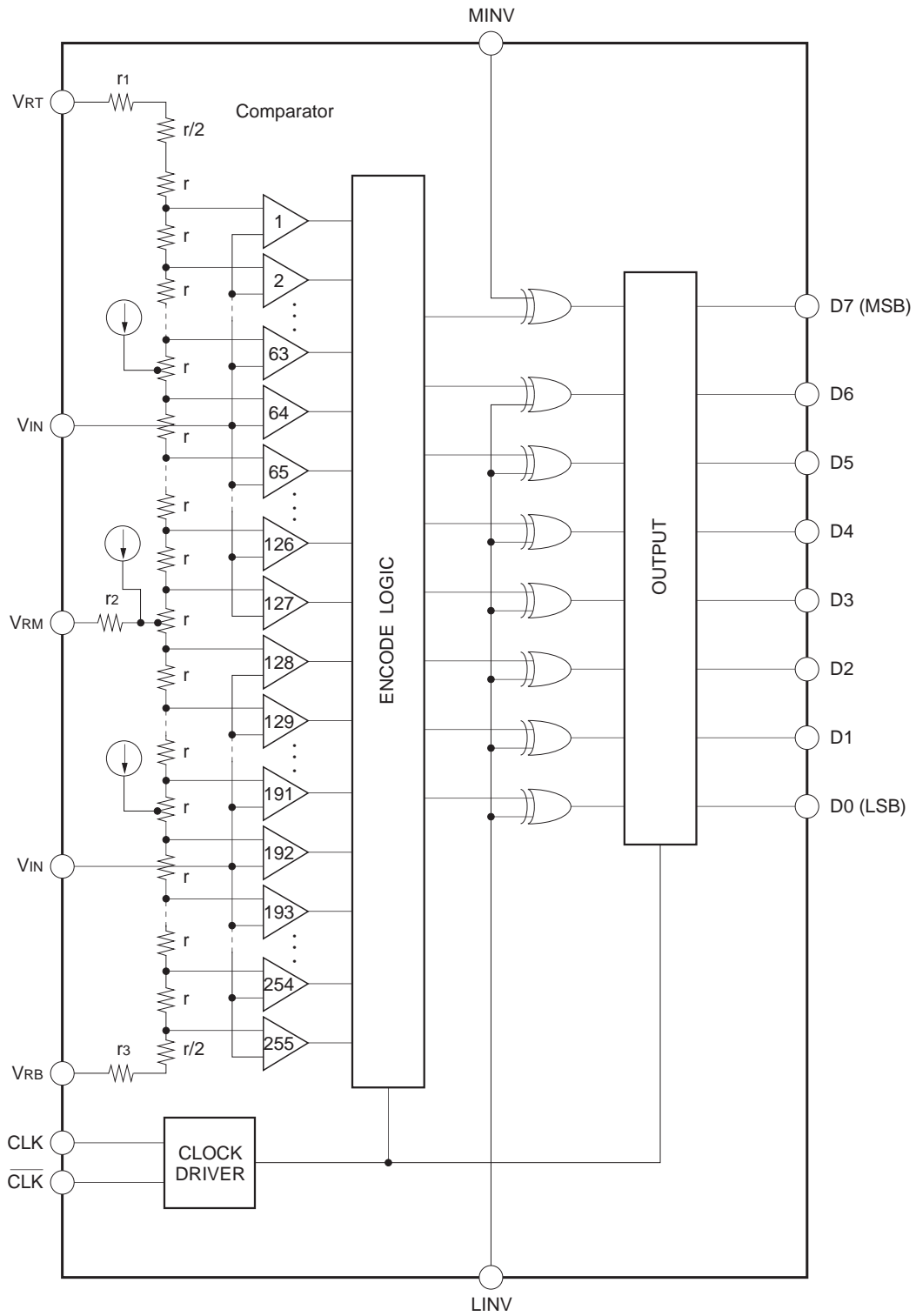

Pin Description and I/O Pin Equivalent Circuit

Pin No.	Symbol	I/O	Standard voltage level	Equivalent circuit	Description
29, 31, 33, 35	AGND	—	0V		Analog GND. Used as GND for input buffers and latches of comparators. Isolated from DGND1, DGND2.
1, 25, 26, 38, 39	AV _{EE}	—	-5.2V		Analog V _{EE} . -5.2V (Typ.). Internally connected with DV _{EE} (resistance: 4 to 6Ω). A ceramic chip capacitor of at least 0.1μF should be used to connect to AGND and be placed near the pins.
21	CLK	I	ECL		CLK input
20	$\overline{\text{CLK}}$				Complementary input to CLK. With open connection, kept at threshold voltage (-1.3V). Device is operable without $\overline{\text{CLK}}$ input, but use of complementary inputs of CLK and $\overline{\text{CLK}}$ is recommended to obtain the stable high-speed operation.
5, 16	DGND1	—	0V		Digital GND for internal circuits.
6, 15	DGND2	—	0V		Digital GND for output transistors.
4, 17	DV _{EE}	—	-5.2V		Digital V _{EE} . Internally connected with AV _{EE} (resistance: 4 to 6Ω). A ceramic chip capacitor of at least 0.1μF should be used to connect to DGND near the pins.

Pin No.	Symbol	I/O	Standard voltage level	Equivalent circuit	Description
7	D0	O	ECL		LSB of data outputs. External pull-down resistor is required.
8	D1				Data outputs. External pull-down resistors are required.
9	D2				
10	D3				
11	D4				
12	D5				
13	D6				MSB of data outputs. External pull-down resistor is required.
14	D7				
3	LINV	I	ECL		Input pin for D0 (LSB) to D6 output polarity inversion (see output code table). With open connection, kept at "L" level.
18	MINV	I	ECL		Input pin for D7(MSB) output polarity inversion (see output code table). With open connection, kept at "L" level.
30, 34	V _{IN}	I	V _{RT} to V _{RB}		<p>Analog input pins. These two pins must be connected externally, since they are not internally connected. See Application Note for precautions.</p>

Pin No.	Symbol	I/O	Standard voltage level	Equivalent circuit	Description
23	V _{RB}	I	-2V		Reference voltage (bottom). Typically -2V. A ceramic capacitor of at least 0.1μF and a tantalum capacitor of at least 10μF should be used to connect to AGND near the pins.
32	V _{RM}	I	V _{RB} /2		Reference voltage mid point. Can be used as a pin for integral linearity compensation.
41	V _{RT}	I	0V		Reference voltage (top). Typically 0V. When a voltage except for AGND is applied to this pin, a ceramic capacitor of at least 0.1μF and a tantalum capacitor of at least 10μF should be used to connect to AGND near the pins.
2, 19, 22, 24, 27, 28, 36, 37, 40, 42	NC	—	—		Unused pins. No internal connections have been made to these pins. Connecting them to AGND or DGND on PC board is recommended.

Electrical Characteristics

(Ta = 25°C, AV_{EE} = DV_{EE} = -5.2V, V_{RT} = 0V, V_{RB} = -2V)

Item	Symbol	Condition	Min.	Typ.	Max.	Unit
Resolution	n			8		bits
DC characteristics						
Integral linearity error	E _{IL}	F _c = 125MSPS		±0.3	±0.5	LSB
Differential linearity error	E _{DL}	F _c = 125MSPS		±0.3	±0.5	LSB
Analog input						
Analog input capacitance	C _{IN}	V _{IN} = -1V + 0.07V _{rms}		17		pF
Analog input resistance	R _{IN}			190		kΩ
Input bias current	I _{IN}	V _{IN} = -1V		130	320	μA
Reference inputs						
Reference resistance	R _{REF}		75	110	155	Ω
Offset voltage V _{RT}	E _{OT}		8	19	32	mV
Offset voltage V _{RB}	E _{OB}		0	15	24	mV
Digital inputs						
Logic H level	V _{IH}		-1.13			V
Logic L level	V _{IL}				-1.50	V
Logic H current	I _{IH}	Input connected to -0.8V	0		50	μA
Logic L current	I _{IL}	Input connected to -1.6V	-50		50	μA
Input capacitance				7		pF
Switching characteristics						
Maximum conversion rate	F _c	Error rate 10 ⁻⁹ TPS*1	125			MSPS
Aperture jitter	T _{aj}			10		ps
Sampling delay	T _{ds}			1.5		ns
Output delay	T _{do}		3.0	3.6	4.2	ns
H pulse width of clock	TPW ₁		4.0			ns
L pulse width of clock	TPW ₀		4.0			ns
Digital outputs						
Logic H level	V _{OH}	R _L = 50Ω to -2V	-1.10			V
Logic L level	V _{OL}	R _L = 50Ω to -2V			-1.62	V
Output rising time	T _r	R _L = 50Ω to -2V, 20% to 80%		0.8		ns
Output falling time	T _f	R _L = 50Ω to -2V, 80% to 20%		1.0		ns
Dynamic characteristics						
Input bandwidth		V _{IN} = 2V _{p-p} , 3dB down	200			MHz
S/N ratio		{ Input = 1MHz, FS Clock = 125MHz		46		dB
		{ Input = 31.5MHz, FS Clock = 125MHz		40		dB
Error rate		{ Input = 31.249MHz, FS Error > 16LSB Clock = 125MHz			10 ⁻⁹	TPS*1
Differential gain error	DG	} NTSC 40IRE mod.ramp,		1.0		%
Differential phase error	DP	} F _c = 125MSPS		0.5		deg
Power supply						
Supply current	I _{EE}		-230	-160		mA
Power consumption*2	P _d			870		mW

*1 TPS: times Per Sample

$$*2 P_d = I_{EE} \cdot V_{EE} + \frac{(V_{RT} - V_{RB})^2}{R_{REF}}$$

Output Code Table

VIN*	Step	MINV 1	0	1	0				
		LINV 1	1	0	0				
		D7	D0	D7	D0	D7	D0	D7	D0
0V	0	0 0 0	0 0	1 0 0	0 0	0 1 1	1 1	1 1 1	1 1
	1	0 0 0	0 1	1 0 0	0 1	0 1 1	1 0	1 1 1	1 0
		⋮		⋮		⋮		⋮	
-1V	127	0 1 1	1 1	1 1 1	1 1	0 0 0	0 0	1 0 0	0 0
	128	1 0 0	0 0	0 0 0	0 0	1 1 1	1 1	0 1 1	1 1
		⋮		⋮		⋮		⋮	
-2V	254	1 1 1	1 0	0 1 1	1 0	1 0 0	0 1	0 0 0	0 1
	255	1 1 1	1 1	0 1 1	1 1	1 0 0	0 0	0 0 0	0 0
		1 1 1	1 1	0 1 1	1 1	1 0 0	0 0	0 0 0	0 0

* V_{RT} = 0V, V_{RB} = -2V

Timing diagram

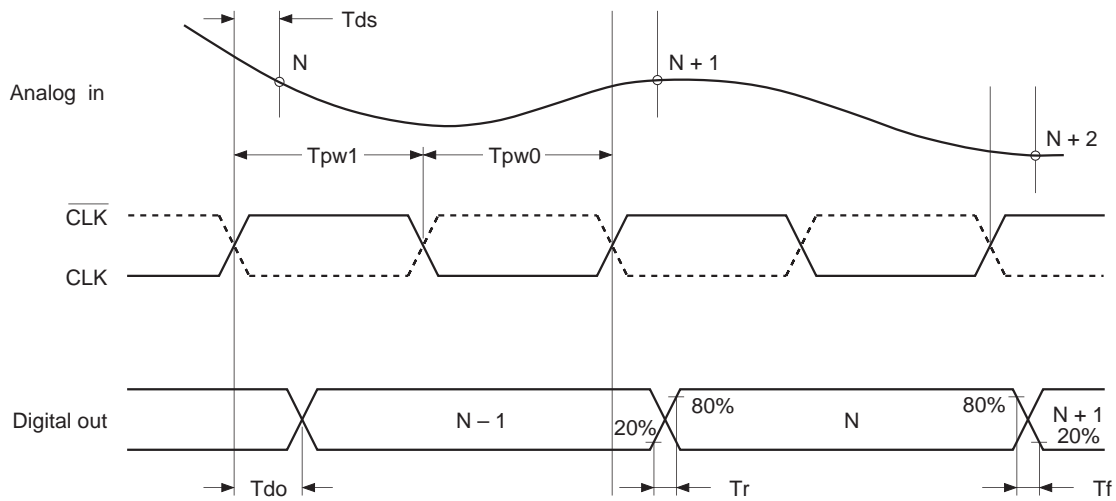

Electrical Characteristics Test Circuit

Maximum conversion rate test circuit

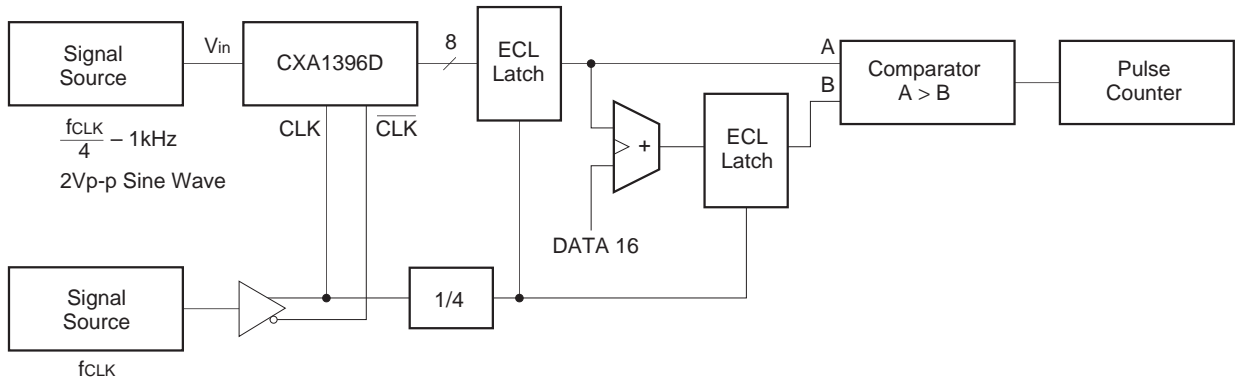

Differential gain error test circuit

Differential phase error test circuit

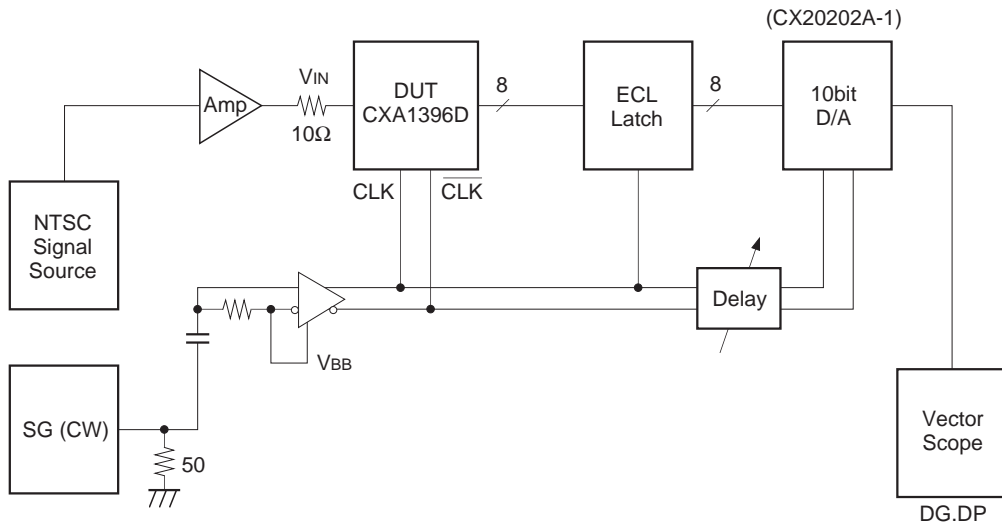

Integral linearity error test circuit

Differential linearity error test circuit

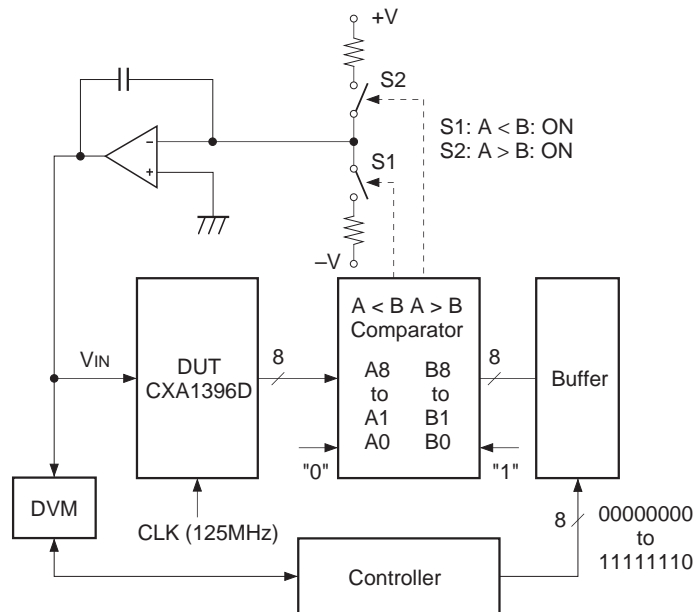

Power Supply Current Test Circuit

Analog input bias current test circuit

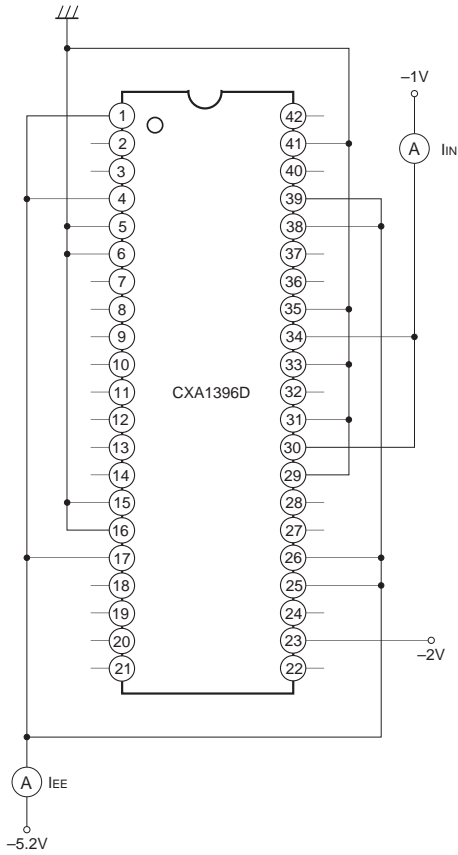

Sampling delay test circuit

Aperture jitter test circuit

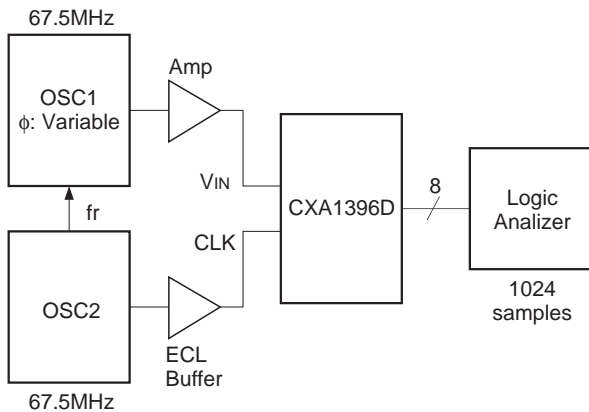

Aperture jitter test method

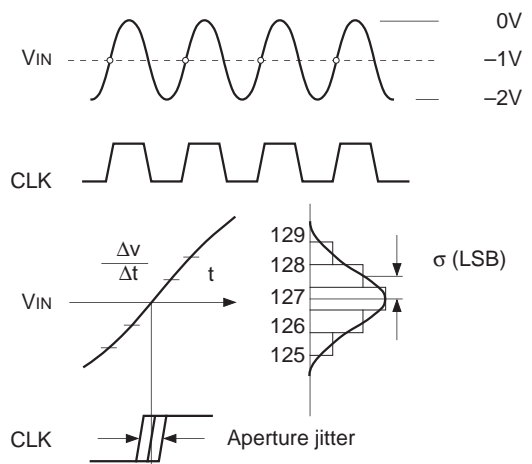

Aperture jitter is defined as follows:

$$T_{aj} = \sigma / \frac{\Delta v}{\Delta t} = \sigma / \left(\frac{256}{2} \times 2\pi f \right),$$

Where σ (unit : LSB) is the deviation of the output codes when the input frequency is exactly the same as the clock and is sampled at the largest slew rate point.

8-bit, 125MSPS ADC Evaluation board

Description

The CXA1396D EVALUATION BOARD WITH DAC is a tool for customers to evaluate the performance of the CXA1396D (8-bit, 125MSPS, high-speed A/D converter). In addition to indispensable features such as the reference voltage generator, this tool equips two sets of analog inputs (the direct input and the buffer amplifier input), the input voltage offset generator, the clock decimator, the output data latches, the 10-bit high-speed DAC, and the 20-pin cable connector for digital outputs.

This evaluation board provides full performance of the CXA1396D and it is designed to facilitate evaluation.

Features

- Resolution: 8bits
- Maximum conversion rate: 125MSPS
- Supply voltage: +5.0V, -5.2V, -2.0V
- Two analog inputs (Direct input, buffer amplifier input)
- Clock level converter: Sine wave to ECL level signal
- Reference voltage adjustment circuit for the A/D converter
- Built-in clock frequency decimation circuit: (1/1 to 1/16)

Fig. 1. Block Diagram

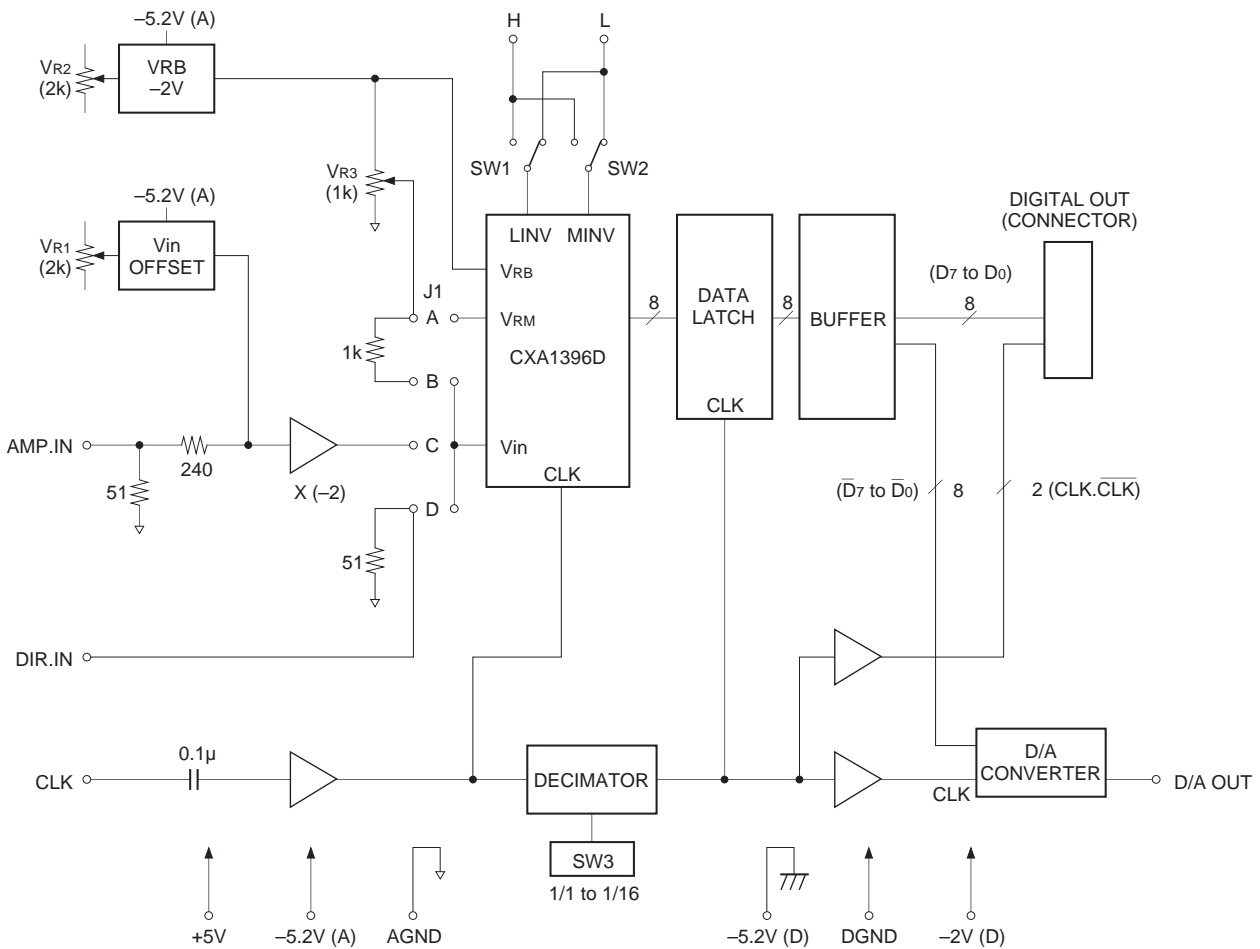

Supply Current

Item	Min.	Typ.	Max.	Unit
-5.2V		0.85	1.0	A
+5.0V		15	30	mA
-2.0V		0.45	0.6	A

(Note: Supply current -2.0V is the value when Rn10, Rn11 and Rn12 are not mounted.)

Analog Input (DIR. IN, AMP. IN)

Item	Min.	Typ.	Max.	Unit
Input voltage (DIR. IN)	-2.0		0	V
(AMP. IN) *1	-0.5		+0.5	V
Input impedance		50		Ω

(*1: Adjustable by VR1)

Clock Input (CLK)

Item	Min.	Typ.	Max.	Unit
Input voltage (Peak to Peak)		1.0		Vp-p
Input impedance		50		Ω

Digital Output (D0 to D7)

ECL 10KH level

Clock Output

ECL 10KH level, complementary output

Output Code Table

	MINV LINV	0 0	0 1	1 0	1 1
V _{IN}	0V	1 1 1 1 1	1 0 0 0 0	0 1 1 1 1	0 0 0 0 0
	:	1 1 1 1 0	1 0 0 0 1	0 1 1 1 0	0 0 0 0 1
	:	:	:	:	:
	:	:	:	:	:
	:	1 0 0 0 0	1 1 1 1 1	0 0 0 0 0	0 1 1 1 1
	:	0 1 1 1 1	0 0 0 0 0	1 1 1 1 1	1 0 0 0 0
	:	:	:	:	:
	:	:	:	:	:
	:	0 0 0 0 1	0 1 1 1 0	1 0 0 0 1	1 1 1 1 0
	-2V	0 0 0 0 0	0 1 1 1 1	1 0 0 0 0	1 1 1 1 1

Fig. 2. Timing Chart

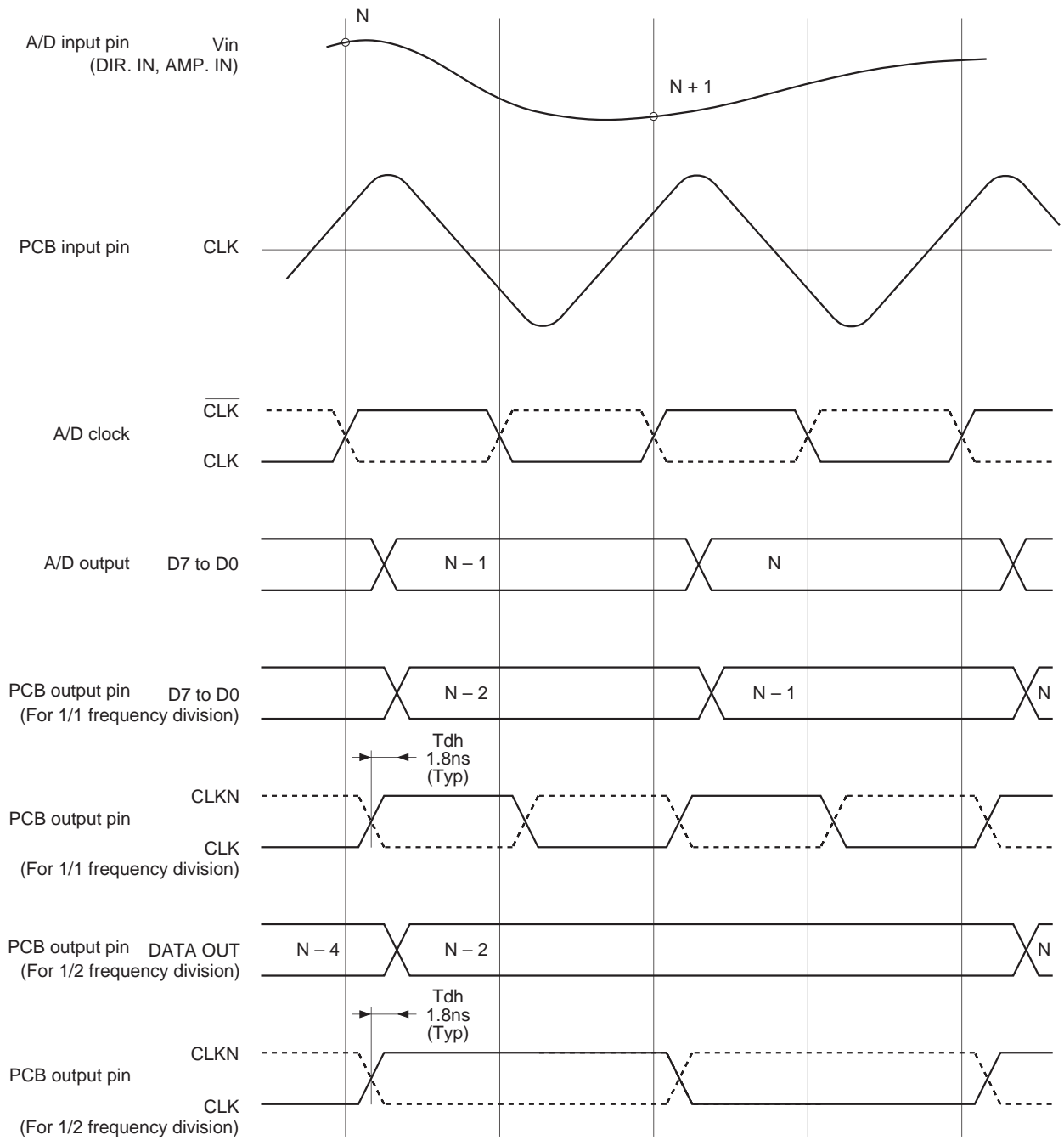

Adjustment Methods and Notes on Operation

- 1) Vin Offset (VR1)
The volume to adjust the signal range (0V center assumed) with the A/D converter input range when a waveform is input through AMP. IN.
- 2) A/D Full Scale (VR2)
The volume to adjust A/D converter VRB voltage.
- 3) Linearity (VR3)
The volume to adjust VRM (linearity) voltage. When DIR. IN input selected and it is supplied through the capacitor, VR3 can be used to adjust the input offset voltage.
- 4) D/A Full Scale (VR4)
The volume to adjust D/A output full scale (-1V).
- 5) J1 (Input selection)
A: Shorts to adjust VRM voltage.
B: Shorts to supply DC voltage to Vin.
C: Shorts to select AMP.IN input.
D: Shorts to select DIR.IN input.

[Jumper Position at Shipment]

J1	J1	J1
A○○ Input through the	A⊖⊖ Input through the	A○○ Input through the capacitor
B○○ buffer amplifier	B○○ buffer amplifier	B⊖⊖ (When the offset is adjusted using the
C⊖⊖	C⊖⊖ (When the linearity	C○○ DIR IN. at the evaluation board)
D○○	D○○ is adjusted)	D○○ 0.1μF

- 6) SW1
The switch for LINV High/Low.
- 7) SW2
The switch for MINV High/Low.
- 8) SW3 (Decimation)
The switch to select clock frequency decimation.
Switch position: decimation ratio
0: 1/1
1: 1/2
2: 1/4
3: 1/8
4: 1/16
- 9) SW4 (D/A INV)
The switch for D/A converter output inversion.

- 10) Rn10, Rn11 and Rn12 are not mounted at shipment. They are not required during evaluation.
- 11) Waveform probe pins P5 and P8 through P28 are devised to facilitate GND connection in order to reduce the distortion. As shown in the diagram below, the distance between the probe point and the GND is 300 mil, and there is $\phi 1.2\text{mm}$ through hole at each. The signal and GND locations are suit for a Tektronix GND tip (part number 013-1185-00).

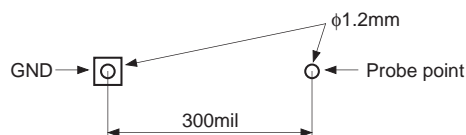
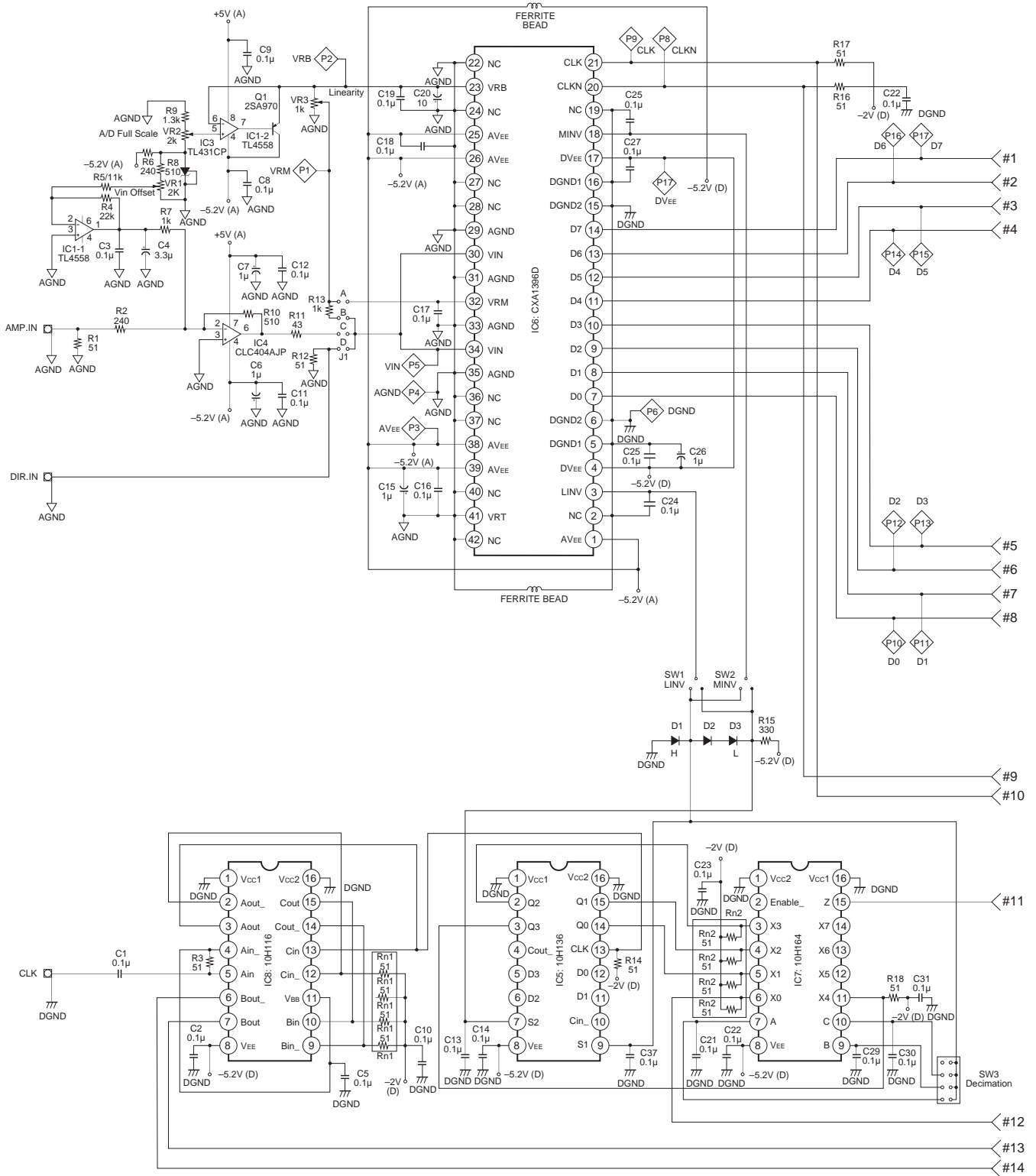
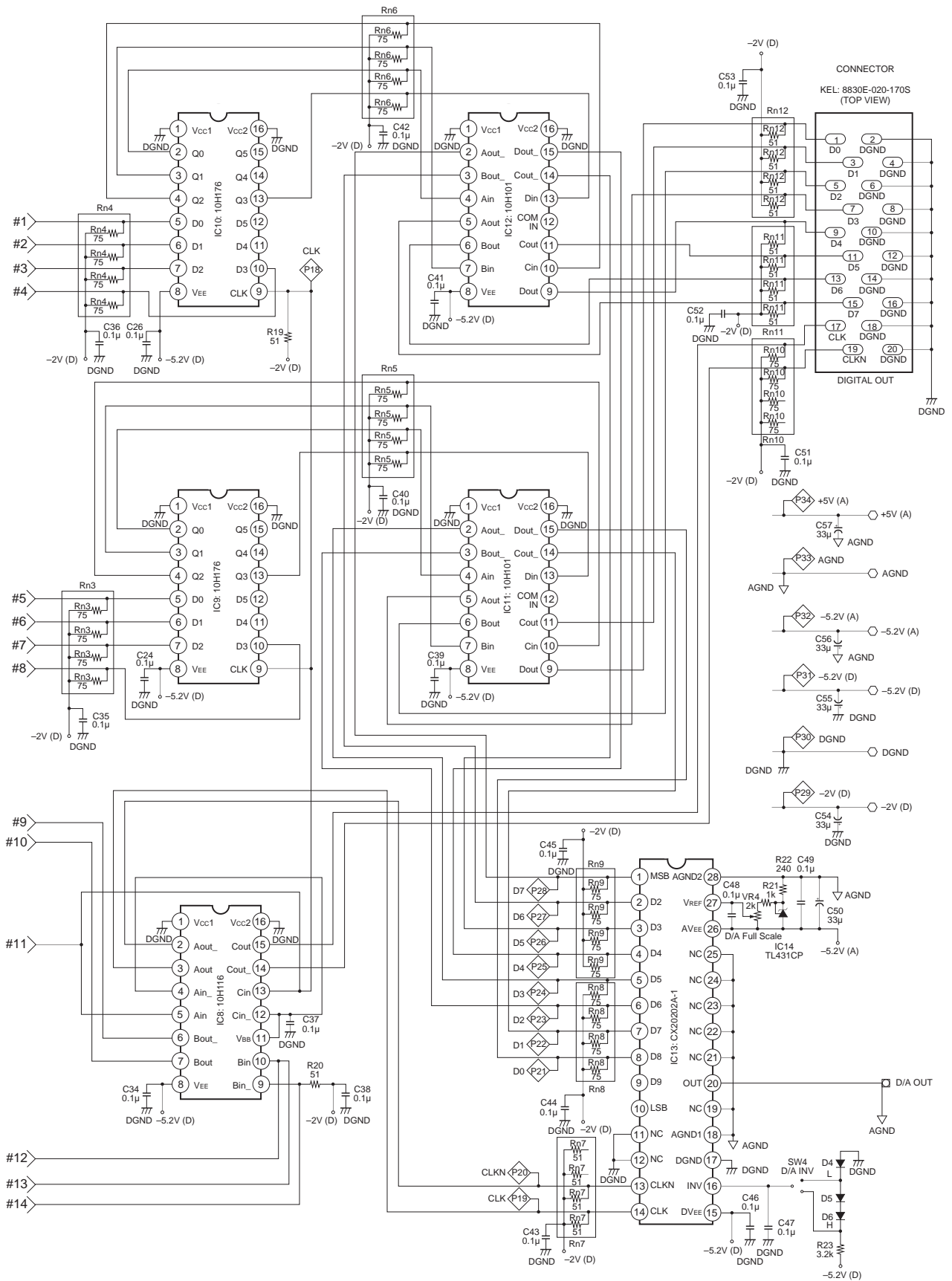

Fig. 3

- 12) D/A converter (IC13) input data (waveform probe pins P21 through P28) are the complementary signals of the decimated A/D converter outputs. Those are inverted again in the D/A converter so that the direction of reproduced waveform can agree with the A/D input signal converter.
- 13) The part number of the digital output connector is KEL 8830E-020-170S. A corresponding connector and cable assembly is JUNKOSMA KBO020MCG50BI.

PCB Circuit Schematic





Characteristic Graph

Fig. 5. Gain vs. Input frequency

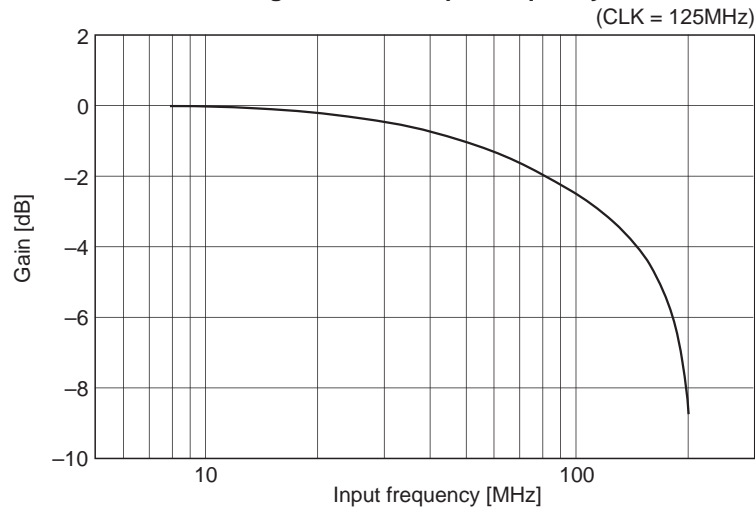

Fig. 6. SNR vs. Input frequency

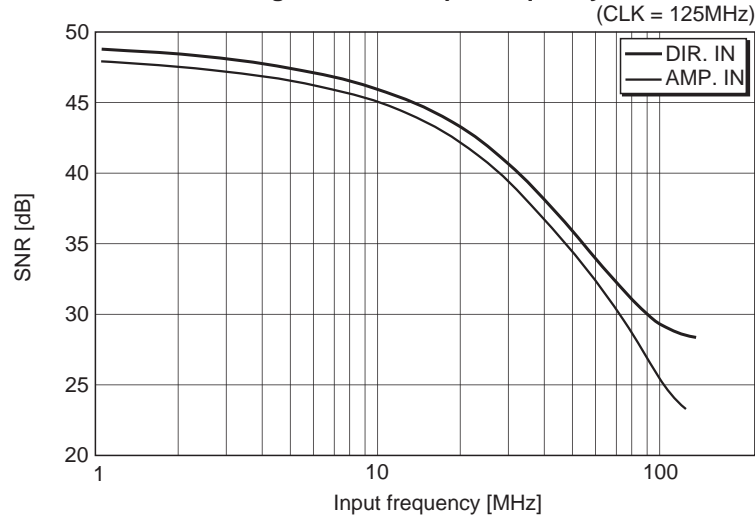
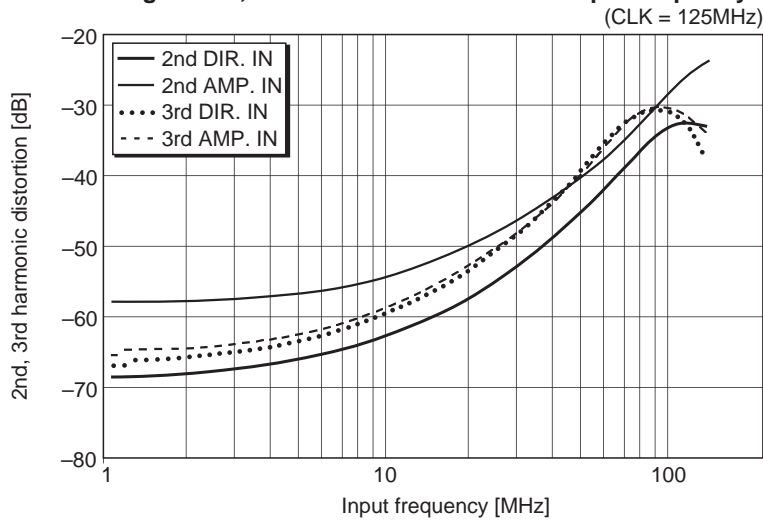

Fig. 7. 2nd, 3rd harmonic distortion vs. Input frequency



Measurement data

Figs. 5, 6 and 7 show the characteristic graphs.

DIR. IN is the characteristic where the signal is directly input to the ADC and AMP. IN is the characteristic where the signal is input to ADC through the amplifier.

Parts Layout

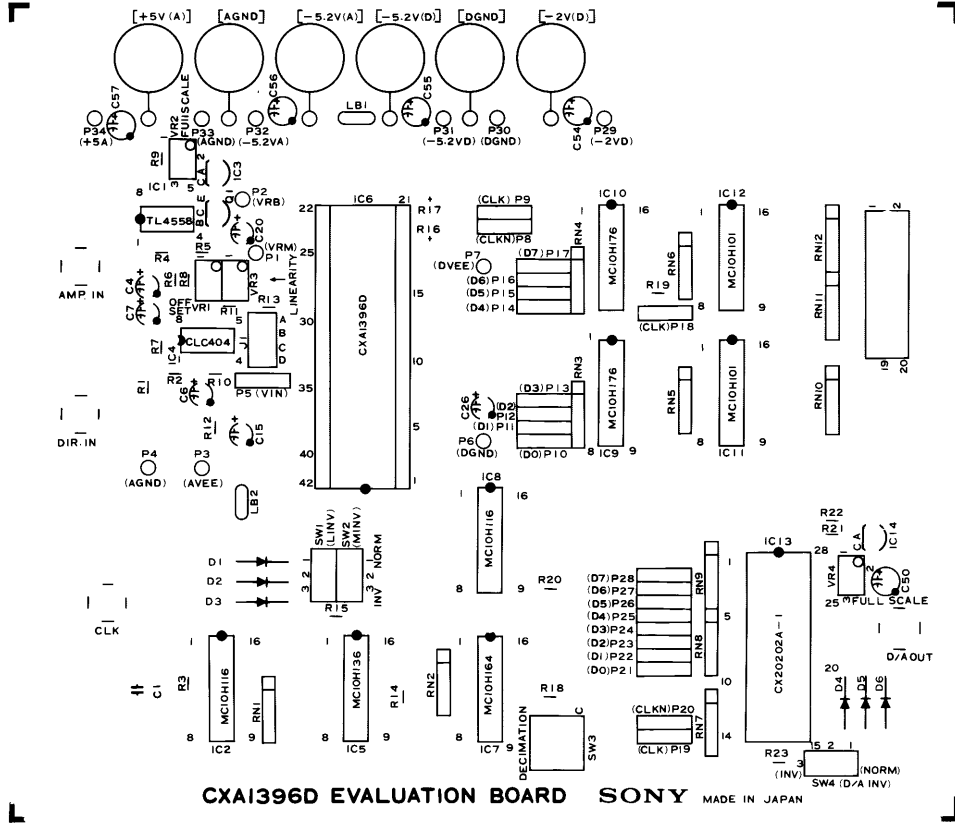

Printed Pattern

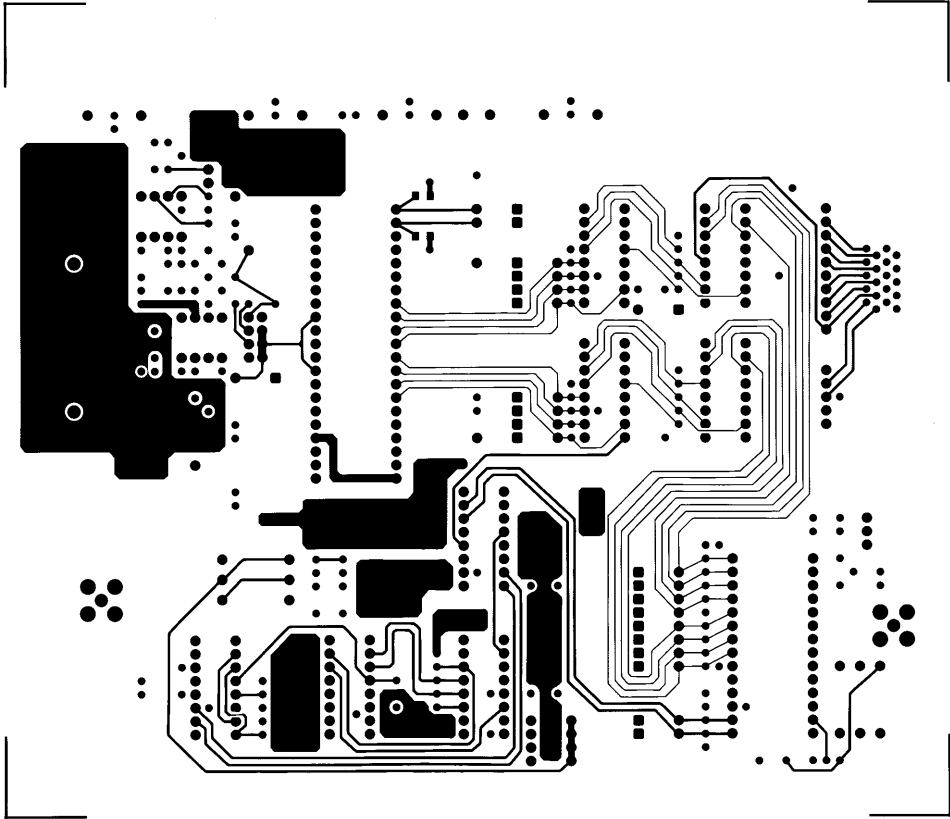

1st layer Component plane (Top View)

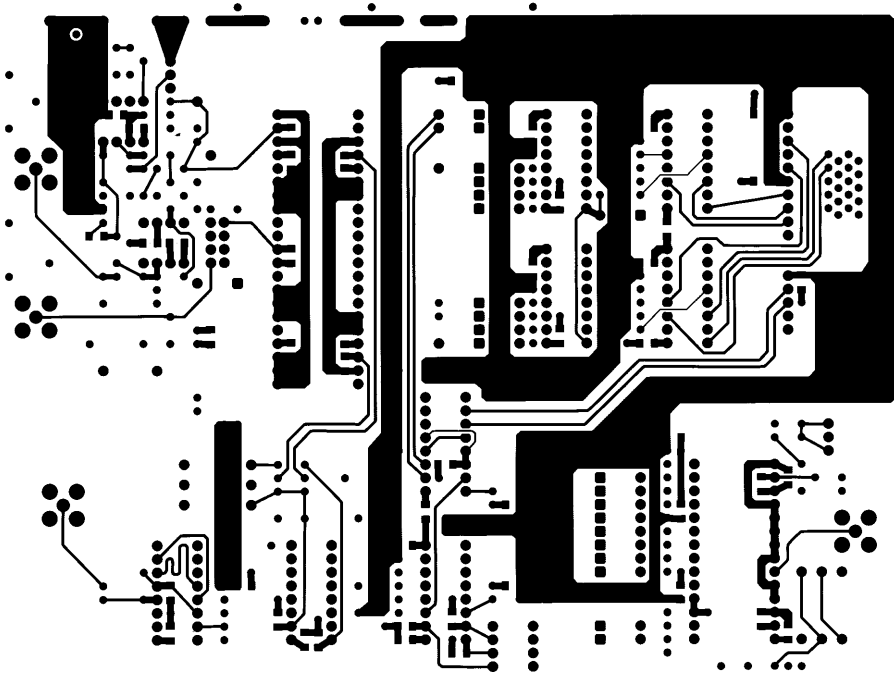

4th layer Solder plane (Top View)

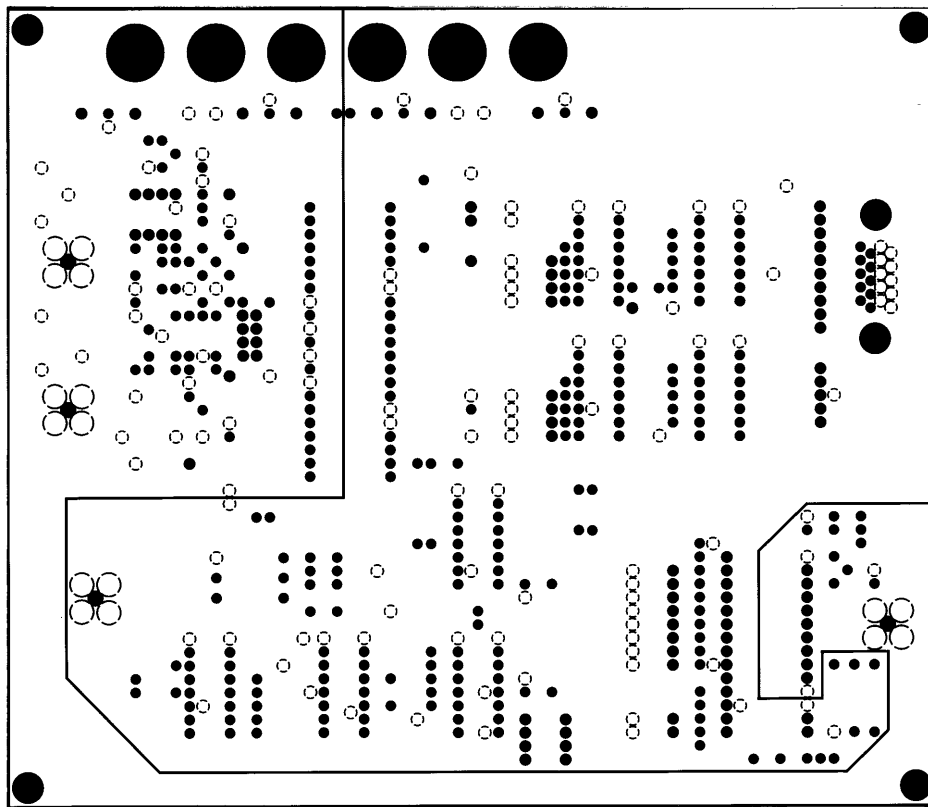

2nd layer GND plane (Top View)

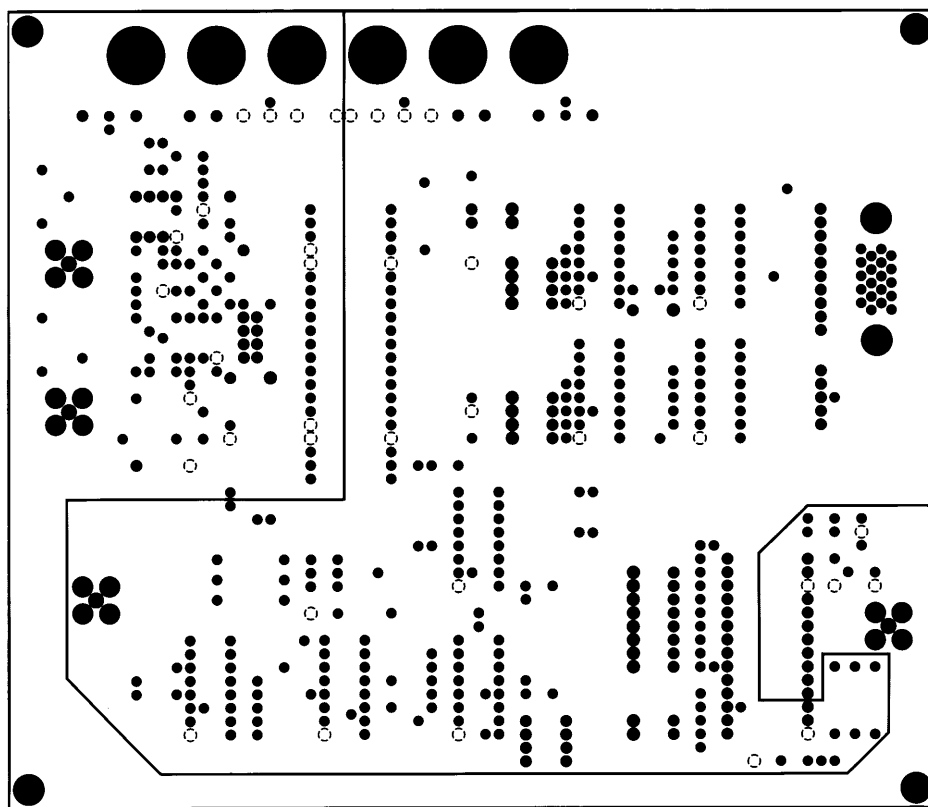

3rd layer Power supply plane (Top View)

Package Outline Unit: mm

42PIN DIP (CERAMIC) 600mil

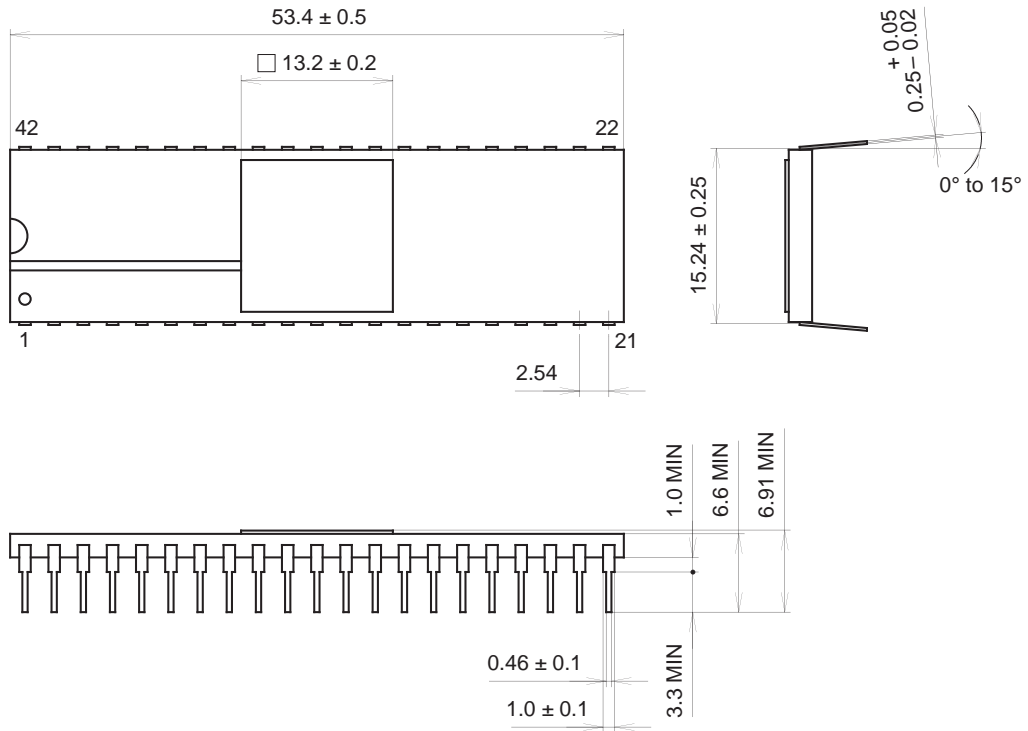

PACKAGE STRUCTURE

SONY CODE	DIP-42C-01
EIAJ CODE	*DIP042-C-0600-A
JEDEC CODE	_____

PACKAGE MATERIAL	CERAMIC
LEAD TREATMENT	GOLD PLATING
LEAD MATERIAL	42 ALLOY
PACKAGE WEIGHT	6.7g



LittleDiode supplies new, hard to find or obsolete electronic components and semiconductors all over the world.

With over two million different components listed you are sure to find the part you need.

Feel free to visit us today at our online store:

LittleDiode.com

Looking forward to providing you with the best possible service.