

8-bit 75MSPS Flash A/D Converter

Description

The CXA1386P/K are 8-bit high-speed flash A/D converter ICs capable of digitizing analog signals at the maximum rate of 75MSPS. The digital I/O levels of these A/D converters are compatible with the ECL 100K/10KH/10K.

The CXA1386P/K is pin-compatible with the earlier models CXA1056P/K, CXA1016P/K, respectively. They can be replaced by the CXA1386P/K without any design changes, in most cases. Compared with the earlier models, these new models have been greatly improved in performance, by incorporating advanced process, new circuit design and carefully considered layout.

Features

- Differential linearity error: $\pm 1/2$ LSB or less
- Integral linearity error: $\pm 1/2$ LSB or less
- High-speed operation with maximum conversion rate of 75MSPS (Min.)
- Wide analog input bandwidth: 150MHz (Min. for full-scale input)
- Low Power consumption: 580mW (Typ.)
- Single power supply: -5.2 V
- Low input capacitance: 17pF (Typ.)
- Built-in integral linearity compensation circuit
- Low error rate
- Operable at 50% clock duty cycle
- Good temperature characteristics
- Capable of driving 50 Ω loads

Pin Configuration

Pins with name are NC pins (not connected).

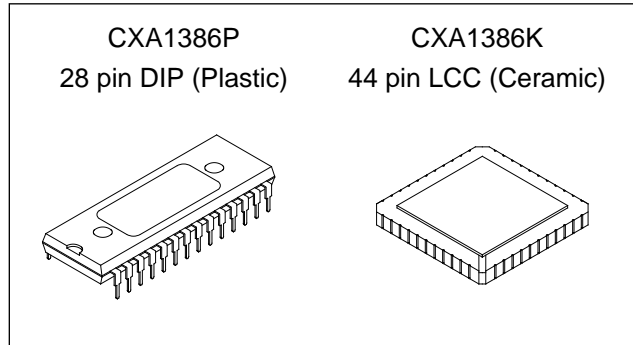
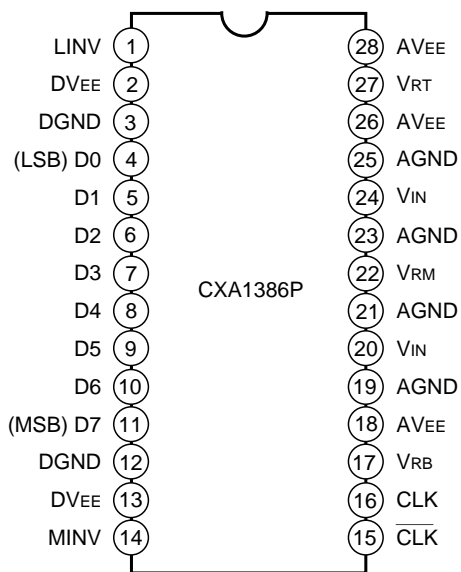

Structure

Bipolar silicon monolithic IC

Applications

- Digital oscilloscopes
- HDTV (high-definition TVs)
- Other apparatus requiring high-speed A/D conversion

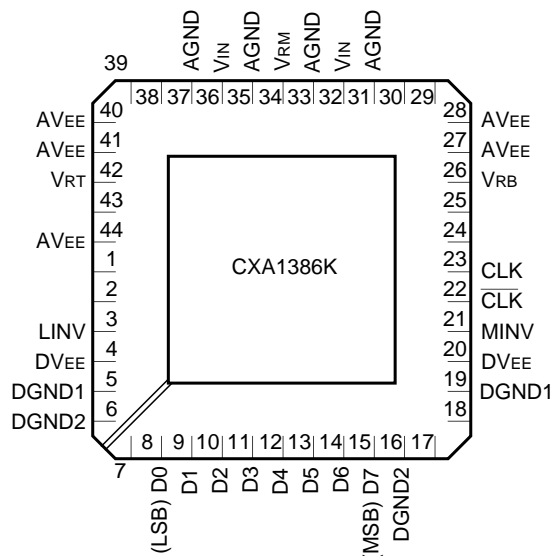

Sony reserves the right to change products and specifications without prior notice. This information does not convey any license by any implication or otherwise under any patents or other right. Application circuits shown, if any, are typical examples illustrating the operation of the devices. Sony cannot assume responsibility for any problems arising out of the use of these circuits.

Absolute Maximum Ratings (Ta = 25°C)

• Supply voltage	AV _{EE} , DV _{EE}	-7 to +0.5	V
• Analog input voltage	V _{IN}	-2.7 to +0.5	V
• Reference input voltage	V _{RT} , V _{RB} , V _{RM}	-2.7 to +0.5	V
	I V _{RT} – V _{RB} I	2.5	V
• Digital input voltage	CLK, $\overline{\text{CLK}}$, MINV, LINV	-4 to +0.5	V
	I CLK – $\overline{\text{CLK}}$ I	2.7	V
• V _{RM} pin input current	I _{VRM}	-3 to +3	mA
• Digital output current	ID ₀ to ID ₇	-30 to 0	mA
• Storage temperature	T _{stg}	-65 to +150	°C

Recommended Operating Conditions

		Min.	Typ.	Max.	Unit
• Supply voltage	AV _{EE} , DV _{EE}	-5.5	-5.2	-4.95	V
	AV _{EE} – DV _{EE}	-0.05	0	+0.05	V
	AGND – DGND	-0.05	0	+0.05	V
• Reference input voltage	V _{RT}	-0.1	0	+0.1	V
	V _{RB}	-2.2	-2.0	-1.8	V
• Analog input voltage	V _{IN}	V _{RB}		V _{RT}	
• Pulse width of clock	T _{PW1}	6.6			ns
	T _{PW0}	6.6			ns
• Operating temperature	T _c (CXA1386K)	-20		+100	°C
	T _a (CXA1386P)	-20		+75	°C

Block Diagram

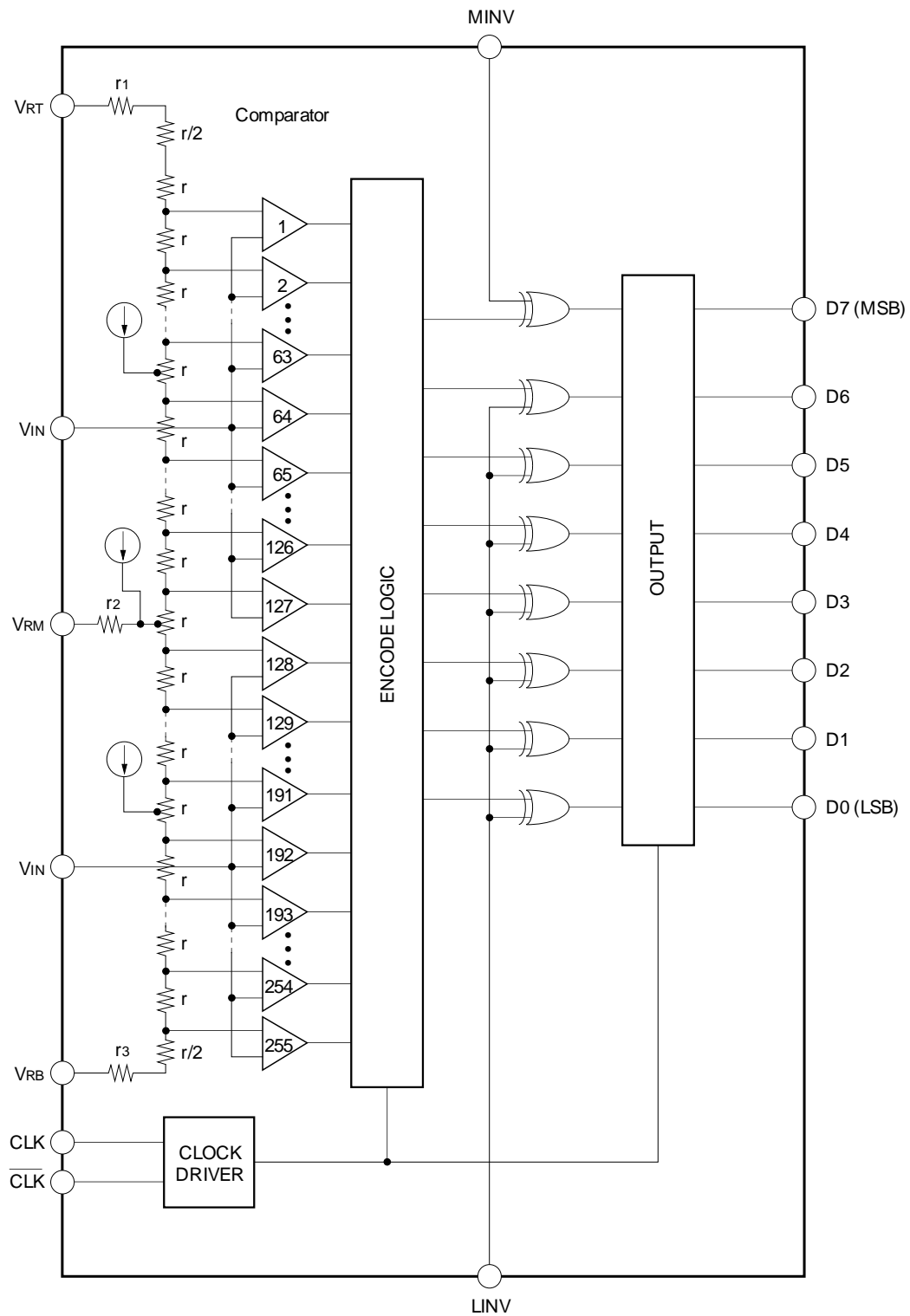

Pin Description and I/O pin Equivalent circuit

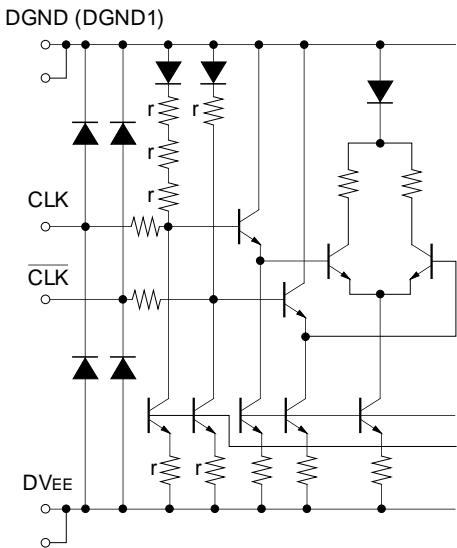
Pin No		Symbol	I/O	Standard voltage level	Equivalent circuit	Description
LCC	DIP					
31, 33, 35, 37	19, 21, 23, 25	AGND	—	0V		Analog GND. Used as GND for input buffers and latches of comparators. Isolated from DGND or DGND 1/2.
27, 28, 40, 41, 44	18, 26, 28	AV _{EE}	—	-5.2V		Analog V _{EE} -5.2V (Typ.). Internally connected with DV _{EE} (resistance: 4 to 6Ω). Ceramic chip capacitors of at least 0.1μF should be used to connect to AGND and be placed near the pins.
23	16	CLK	I	ECL		CLK input
22	15	$\overline{\text{CLK}}$				Input complementary to CLK. With open connection, kept at threshold voltage (-1.3V). Device is operable without CLK input, but use of complementary inputs of CLK and $\overline{\text{CLK}}$ is recommended to obtain the stable high-speed operation.
—	3, 12	DGND	—	0V		Digital GND (Used for internal circuits and output transistors)
5, 19	—	DGND1	—	0V		Digital GND (Used for internal circuits)
6, 16	—	DGND2	—	0V		Digital GND (Used for output buffers)

Pin No		Symbol	I/O	Standard voltage level	Equivalent circuit	Description
LCC	DIP					
4, 20	2, 13	DVEE	—	-5.2V		Digital VEE Internally connected with AVEE (resistance: 4 to 6Ω) Ceramic chip capacitors of at least 0.1μF should be used to connect to DGND and be placed near the pins.
8	4	D0	O	ECL		LSB of data outputs. External pull-down resistor is required.
9	5	D1				Data outputs. External pull-down resistors are required.
10	6	D2				
11	7	D3				
12	8	D4				
13	9	D5				
14	10	D6				
15	11	D7		MSB of data outputs. External pull-down resistor is required.		
3	1	LINV	I	ECL		Input pin for D0 (LSB) to D6 output polarity inversion (see output code table). With open connection, kept at "L" level.
21	14	MINV	I	ECL		Input pin for D7 (MSB) output polarity inversion (see output code table). With open connection, kept at "L" level.

Pin No.		Symbol	I/O	Standard voltage level	Equivalent circuit	Description
LCC	DIP					
32, 36	20, 24	V_{IN}	I	V_{RT} to V_{RB}		<p>Analog input pins. These two pins must be connected externally, since they are not internally connected. See Application Note for precautions.</p>
26	17	V_{RB}	I	-2V		<p>Reference voltage (bottom) Typically -2V A ceramic capacitor of at least 0.1μF and a tantalus capacitor of at least 10μF should be used to connect to AGND and be placed near the pins.</p>
34	22	V_{RM}	I	$V_{RB}/2$		<p>Reference voltage mid point be used as a pin for integral linearity compensation</p>
42	27	V_{RT}	I	0V		<p>Reference voltage (top) Typically 0V When a voltage different from AGND is applied to this pin, a ceramic capacitor of at least 0.1μF and a tantalus capacitor of at least 10μF should be used to connect to AGND and be placed near the pins.</p>
1, 2, 7, 17, 18, 24, 25, 29, 30, 38, 39, 43		NC	—	—		<p>Unused pins No internal connections have been made to these pins. Connecting them to AGND or DGND on PC board is recommended.</p>

Electrical Characteristics

(Ta = 25°C, AV_{EE} = DV_{EE} = -5.2V, V_{RT} = 0V, V_{RB} = -2V)

Item	Symbol	Condition	Min.	Typ.	Max.	Unit
Resolution	n			8		bits
DC characteristics						
Integral linearity error	E _{IL}	F _c = 75MSPS		±0.3	±0.5	LSB
Differential linearity error	E _{DL}	F _c = 75MSPS		±0.3	±0.5	LSB
Analogue input						
Analog input capacitance	C _{IN}	V _{IN} = -1V + 0.07V _{rms}		17		pF
Analog input resistance	R _{IN}			390		kΩ
Input bias current	I _{IN}	V _{IN} = -1V			200	μA
Reference inputs						
Reference resistance	R _{REF}		75	110	155	Ω
Offset voltage	V _{RT} E _{OT}		8	18	32	mV
	V _{RB} E _{OB}		0	10	24	mV
Digital inputs						
Logic H level	V _{IH}		-1.13			V
Logic L level	V _{IL}				-1.50	V
Logic H current	I _{IH}	Input connected to -0.8V	0		50	μA
Logic L current	I _{IL}	Input connected to -1.6V	-50		50	μA
Input capacitance				7		pF
Switching characteristics						
Maximum conversion rate	F _c	Error rate 10 ⁻⁹ TPS*1	75			MSPS
Aperture jitter	T _{aj}			10		ps
Sampling delay	T _{ds}			3.0		ns
Output delay	T _{do}		4.0	6.5	9.0	ns
H pulse width of clock	T _{PW1}		6.6			ns
L pulse width of clock	T _{PW0}		6.6			ns
Digital outputs						
Logic H level	V _{OH}	R _L = 620Ω to DV _{EE}	-1.03			V
Logic L level	V _{OL}	R _L = 620Ω to DV _{EE}			-1.62	V
Output rising time	T _r	R _L = 620Ω to DV _{EE} , 20% to 80%		0.9		ns
Output falling time	T _f	R _L = 620Ω to DV _{EE} , 80% to 20%		2.1		ns
Dynamic characteristics						
Input bandwidth		V _{IN} = 2V _{p-p} Input frequency at -3dB	150			MHz
S/N ratio		{ Input = 1MHz, FS Clock = 75MHz		46		dB
		{ Input = 18.75MHz, FS Clock = 75MHz		40		dB
Error rate		{ Input = 18.749MHz, FS Error > 16LSB Clock = 75MHz			10 ⁻⁹	TPS*1
Differential gain error	DG	} NTSC 40IRE mod. ramp, F _c = 75MSPS		1.0		%
Differential phase error	DP			0.5		deg
Power supply						
Supply current	I _{EE}		-150	-104		mA
Power consumption*2	P _d			580		mW

*1 TPS: Times Per Sample

$$*2 P_d = I_{EE} \cdot V_{EE} + \frac{(V_{RT} - V_{RB})^2}{R_{REF}}$$

Output Code Table

VIN*	Step	MINV 1	0	1	0				
		LINV 1	1	0	0				
		D7	D0	D7	D0	D7	D0	D7	D0
0V	0	0 0 0	0 0	1 0 0	0 0	0 1 1	1 1	1 1 1	1 1
	1	0 0 0	0 0	1 0 0	0 0	0 1 1	1 1	1 1 1	1 1
		⋮		⋮		⋮		⋮	
-1V	127	0 1 1	1 1	1 1 1	1 1	0 0 0	0 0	1 0 0	0 0
	128	1 0 0	0 0	0 0 0	0 0	1 1 1	1 1	0 1 1	1 1
		⋮		⋮		⋮		⋮	
-2V	254	1 1 1	1 0	0 1 1	1 0	1 0 0	0 1	0 0 0	0 1
	255	1 1 1	1 1	0 1 1	1 1	1 0 0	0 0	0 0 0	0 0
		⋮		⋮		⋮		⋮	
		1 1 1	1 1	0 1 1	1 1	1 0 0	0 0	0 0 0	0 0

* VRT = 0V, VRB = -2V

Timing diagram

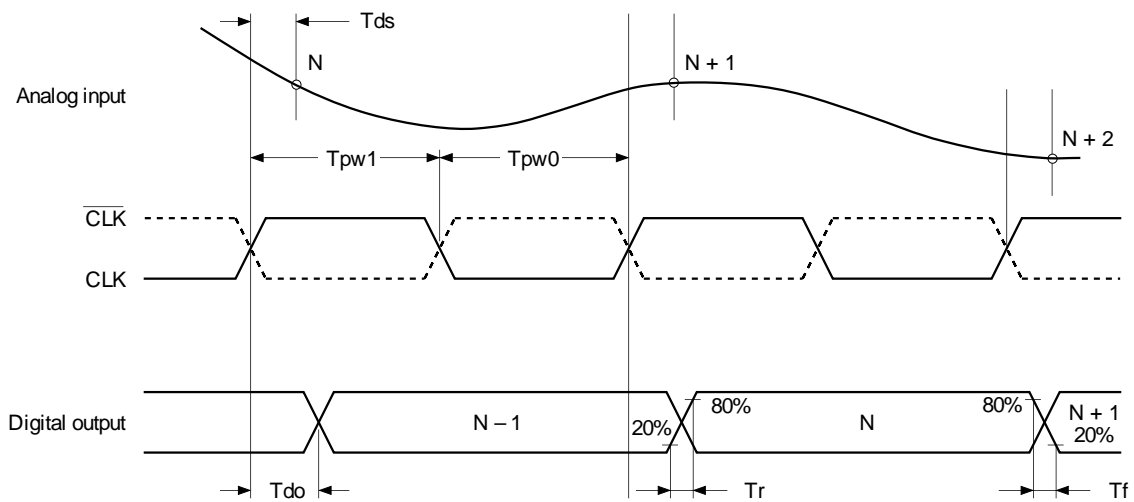

Electrical Characteristics Test Circuit

Maximum conversion rate test circuit

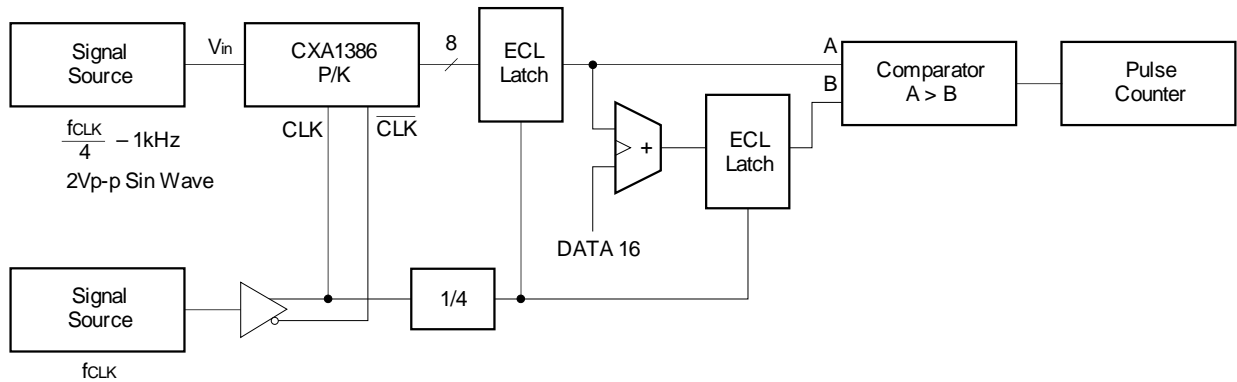

Differential gain error test circuit

Differential phase error test circuit

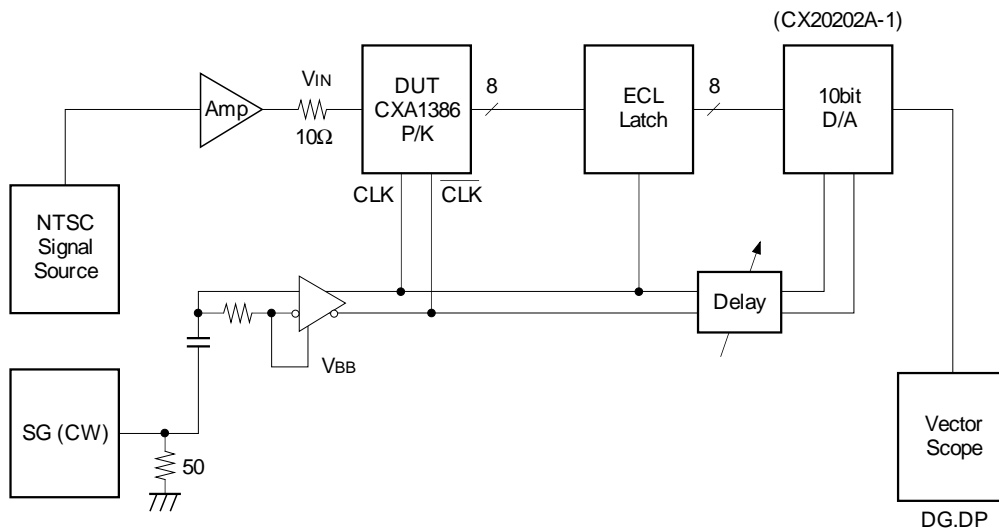

Integral linearity error test circuit

Differential linearity error test circuit

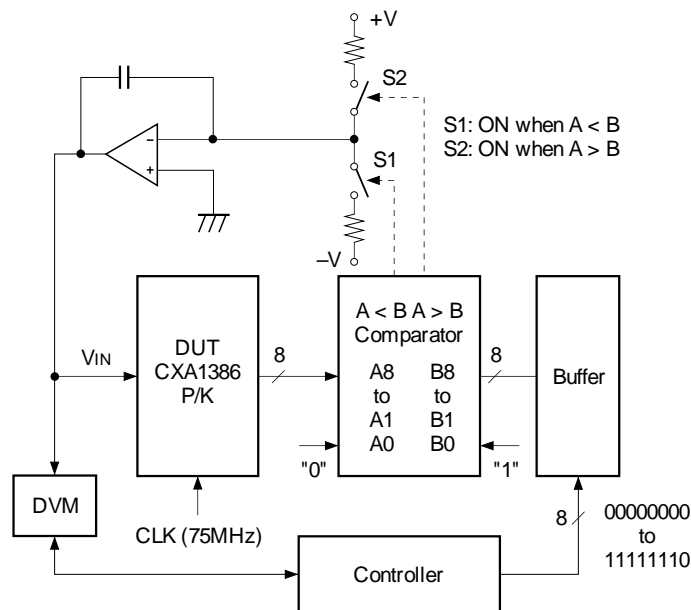

Power Supply Current Test Circuit
Analog input bias current test circuit

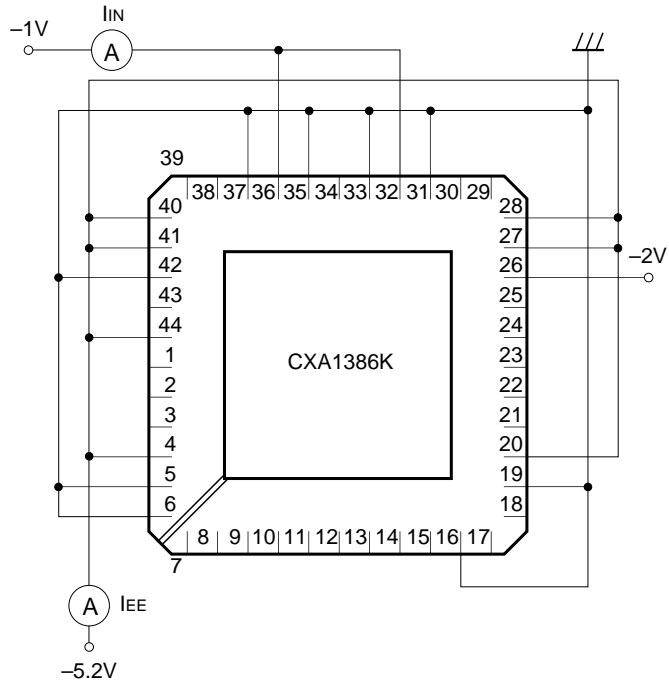
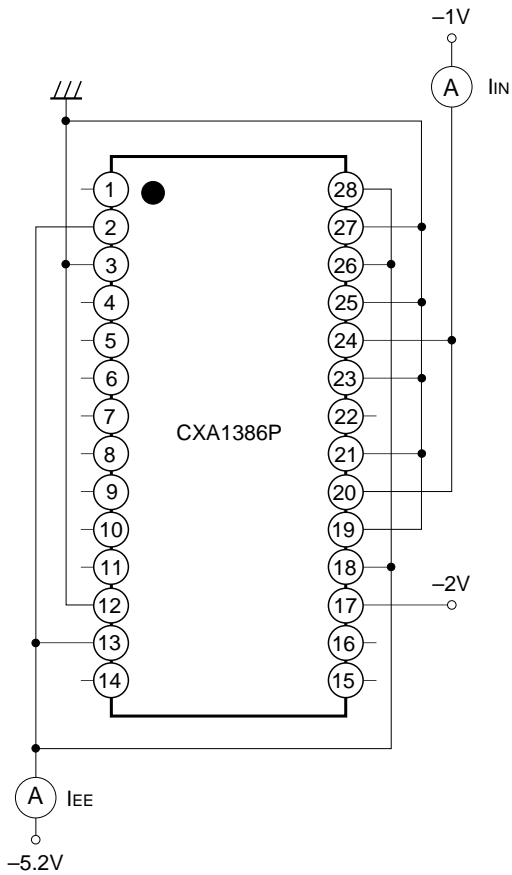

Sampling delay test circuit
Aperture jitter test circuit

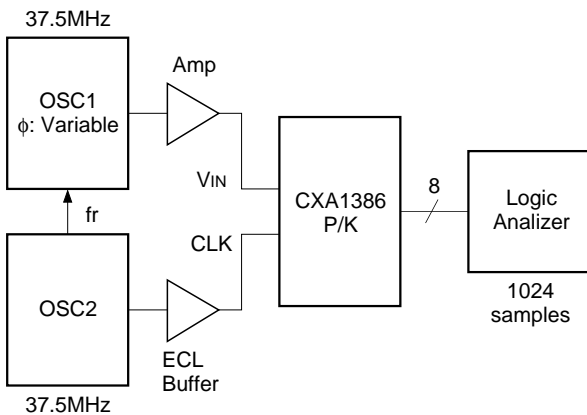

Aperture jitter test method

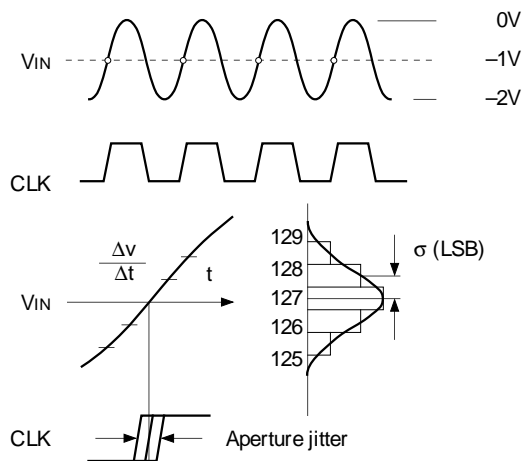

Aperture jitter is defined as follows:

$$T_{aj} = \sigma / \frac{\Delta v}{\Delta t} = \sigma / \left(\frac{256}{2} \times 2\pi f \right),$$

Where σ (unit: LSB) is the deviation of the output codes when the input frequency is exactly the same as the clock and is sampled at the largest slew rate point.

8bit 75MSPS ADC and DAC Evaluation Board

It is necessary to equip "the CXA1396D/P EVALUATION BOARD WITH DAC" with "A1396D – A1386P ADAPTER" in order to evaluate CXA1386P.

In addition to indispensable features such as the reference voltage generator, this tool equips two sets of analog inputs (the direct input and the buffer amplifier input), the input voltage offset generator, the clock decimator, the output data latches, the 10-bit high-speed DAC, and the 20-pin cable connector for digital outputs. This evaluation board provides full performance of the CXA1386P and it is designed to facilitate evaluation.

Features

- Resolution: 8bits
- Maximum conversion rate: 75MSPS
- Supply voltage: +5.0V, -5.2V, -2.0V
- Two analog inputs (Direct input, buffer amplifier input)
- Clock level converter: Sine wave to ECL level signal
- Reference voltage adjustment circuit for the A/D converter
- Built-in clock frequency decimation circuit: (1/1 to 1/16)

Fig. 1. Block Diagram

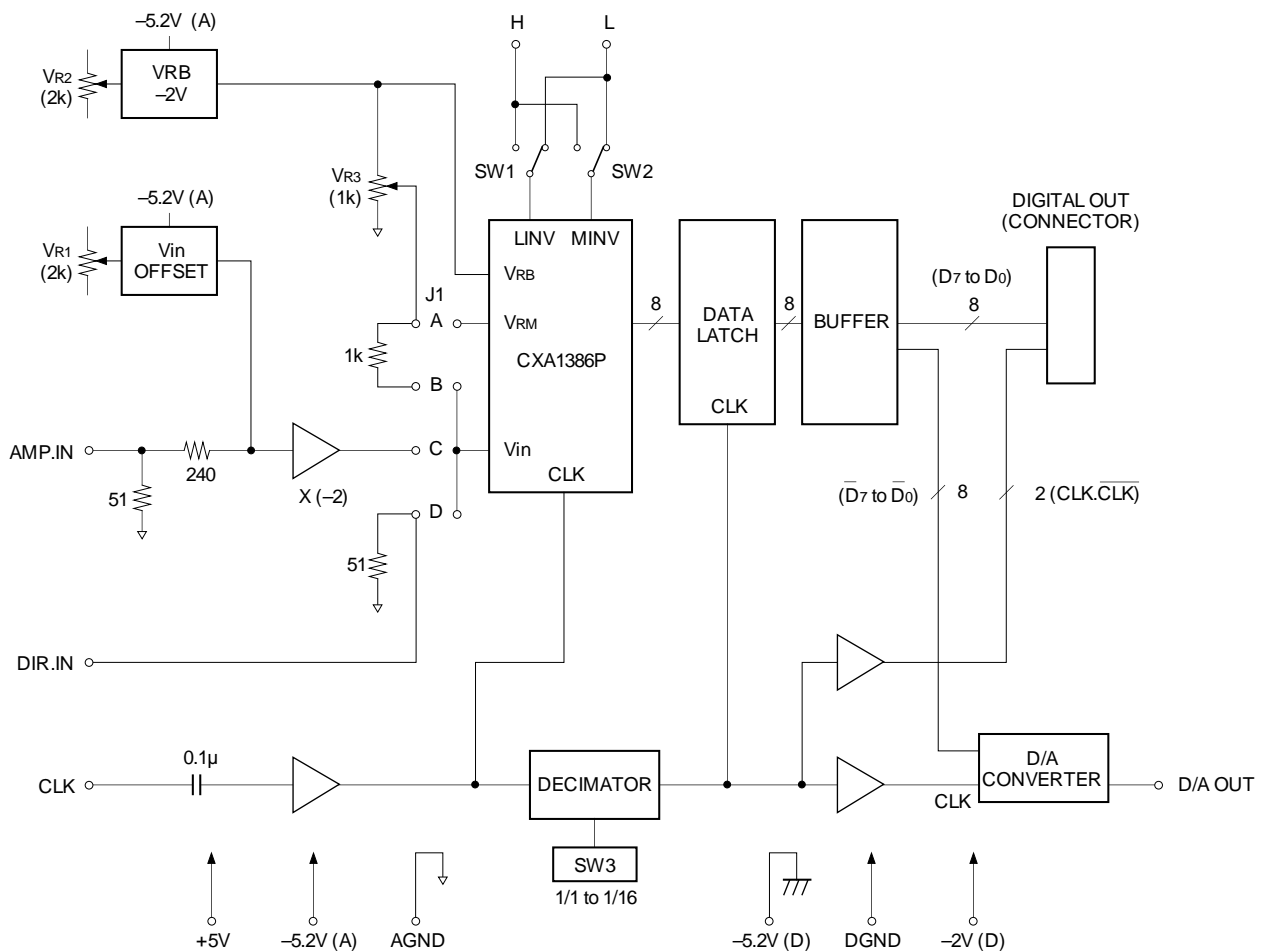

Supply Current

Item	Min.	Typ.	Max.	Unit
-5.2V		0.85	1.0	A
+5.0V		15	30	mA
-2.0V		0.45	0.6	A

(Note: Supply current -2.0V is the value when Rn10, Rn11 and Rn12 are not mounted.)

Analog Input (DIR. IN, AMP. IN)

Item	Min.	Typ.	Max.	Unit
Input voltage (DIR. IN)	-2.0		0	V
(AMP. IN)*1	-0.5		+0.5	V
Input impedance		50		Ω

(*1: Adjustable by VR1)

Clock Input (CLK)

Item	Min.	Typ.	Max.	Unit
Input voltage (Peak to Peak)		2.0		Vp-p
Input impedance		50		Ω

Digital Output (D0 to D7)

ECL 10KH level

Clock Output

ECL 10KH level, complementary output

Output Code Table

	MINV LINV	0 0	0 1	1 0	1 1
V _{IN}	0V	1 1 1 1 1	1 0 0 0 0	0 1 1 1 1	0 0 0 0 0
	:	1 1 1 1 0	1 0 0 0 1	0 1 1 1 0	0 0 0 0 1
	:	:	:	:	:
	:	:	:	:	:
	:	1 0 0 0 0	1 1 1 1 1	0 0 0 0 0	0 1 1 1 1
	:	0 1 1 1 1	0 0 0 0 0	1 1 1 1 1	1 0 0 0 0
	:	:	:	:	:
	:	:	:	:	:
	:	0 0 0 0 1	0 1 1 1 0	1 0 0 0 1	1 1 1 1 0
	-2V	0 0 0 0 0	0 1 1 1 1	1 0 0 0 0	1 1 1 1 1

Fig. 2. Timing Chart

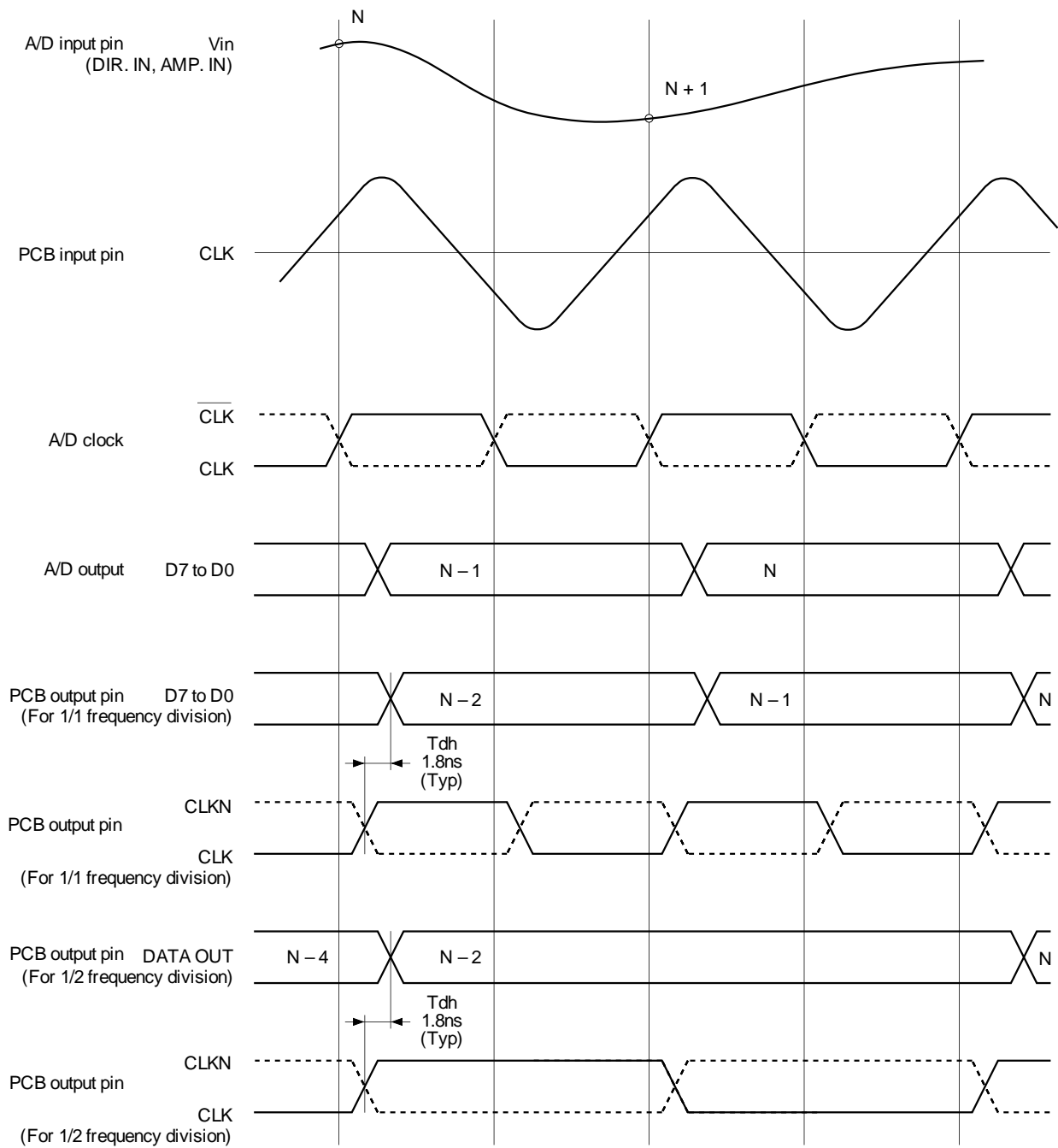

Adjustment Methods and Notes on Operation

- 1) V_{in} Offset (VR1)
The volume to adjust the signal range (0V center assumed) with the A/D converter input range when a waveform is input through AMP. IN.
- 2) A/D Full Scale (VR2)
The volume to adjust A/D converter VRB voltage.
- 3) Linearity (VR3)
The volume to adjust VRM (linearity) voltage.

4) D/A Full Scale (VR4)
The volume to adjust D/A output full scale (-1V)

5) J1 (input selection)	[Jumper Poision at shipment]
A: Shorts to adjust VRM voltage.	J1
B: Shorts to supply DC voltage to Vin.	A ○ ○
C: Shorts to select AMP.IN input.	B ○ ○
D: Shorts to select DIR. IN input.	C ⊕ ⊕
	D ○ ○

6) SW1
The switch for LINV High/Low

7) SW2
The switch for MINV High/Low

8) SW3 (Decimation)
The switch to select clock frequency decimation.
Switch position: decimation ratio
0: 1/1
1: 1/2
2: 1/4
3: 1/8
4: 1/16

9) SW4 (D/A INV)
The switch for D/A converter output inversion.

10) Rn10, Rn11 and Rn12 are not mounted at shipment. They are not required during evaluation.

11) Waveform probe pins P5 and P8 through P28 are devised to facilitate GND connection in order to reduce the distortion. As shown in the diagram below, the distance between the probe point and the GND is 300 mils, and there is $\phi 1.2\text{mm}$ throughhole at each. The signal and GND locations are suit for a Tektronix GND tip (part number 013-1185-00).

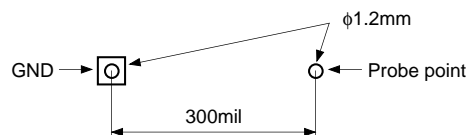

Fig. 3.

12) D/A converter (IC13) input data (waveform probe pins P21 through P28) are the complementary signals of the decimated A/D converter outputs. Those are inverted again in the D/A converter so that the direction of reproduced waveform can agree with the A/D input signal converter.

13) The part number of the digital output connector is KEL 8830E-020-170S. A corresponding connector and cable assembly is JUNKOSHA KB0020MCG50BI.

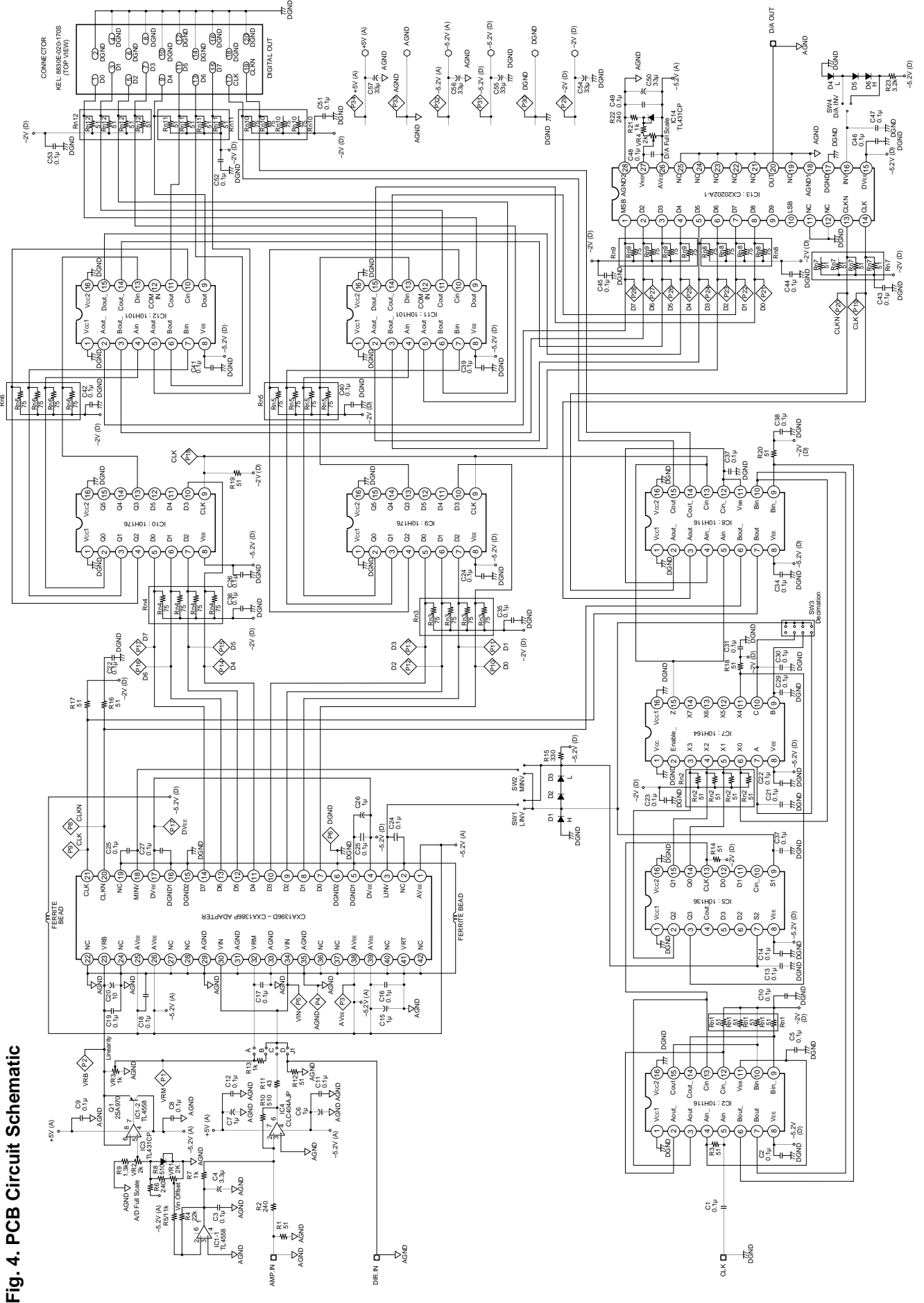

Fig. 4. PCB Circuit Schematic

Characteristics Graphs

Fig 5. CXA1386P SNR vs. Input Frequency

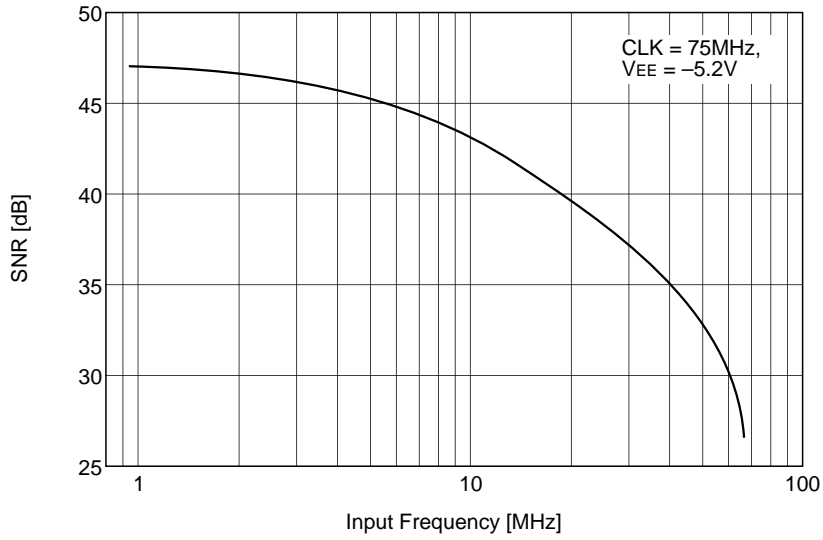

Fig. 6. CXA1386P Effective Bits vs. Input Frequency

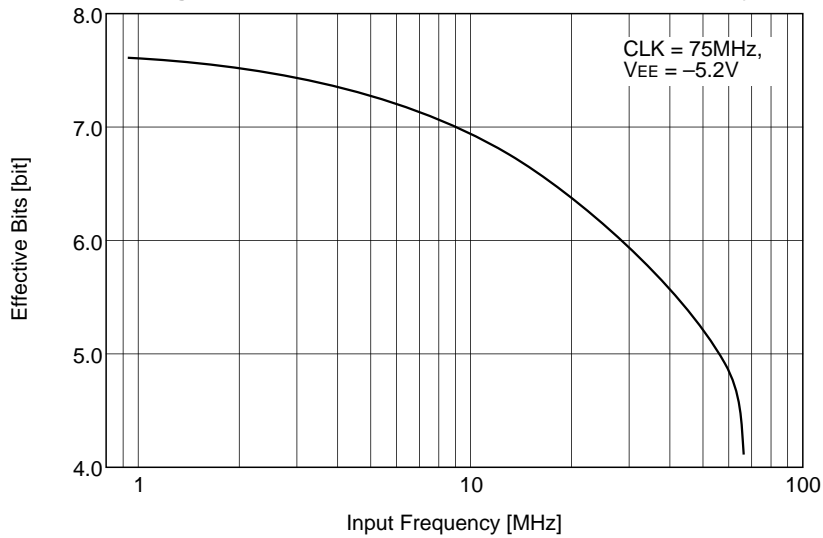
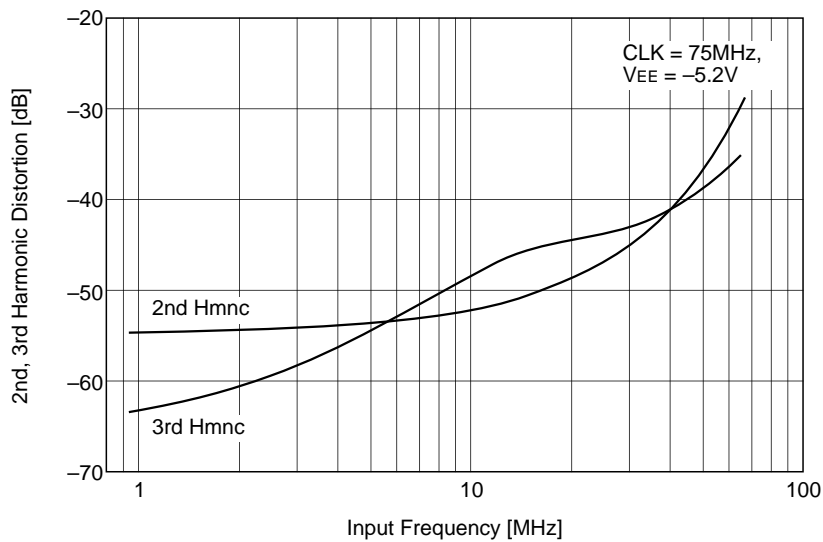
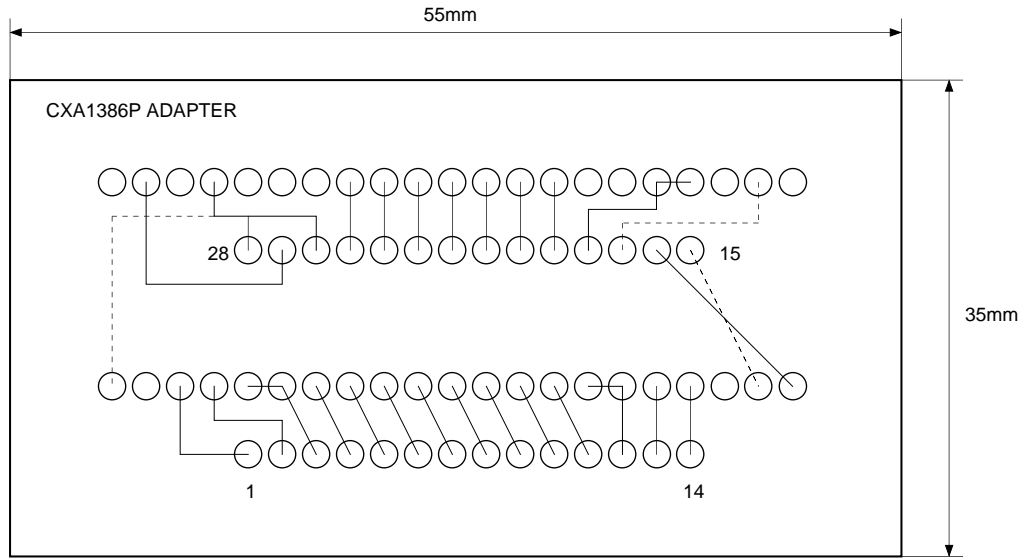

Fig. 7. CXA1386P 2nd, 3rd Harmonic Distortion vs. Input Frequency



CXA1396D – CXA1386P ADAPTER (SCALE = 2/1)



TOP VIEW

Printed Pattern

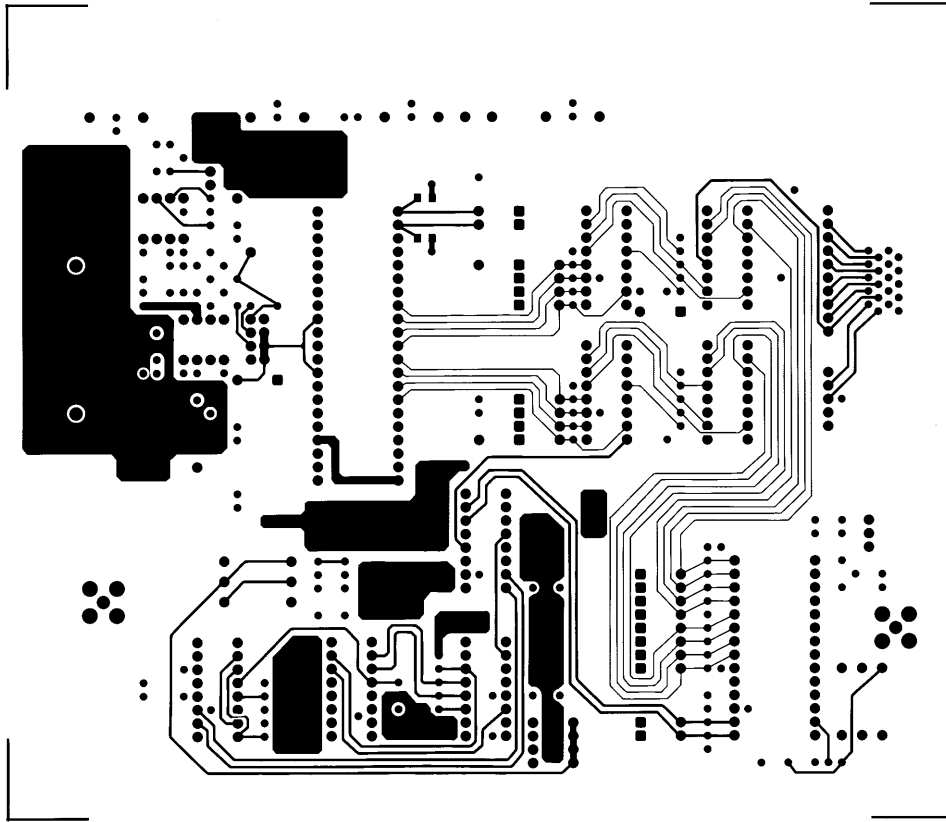

1st layer Component plane (Top View)

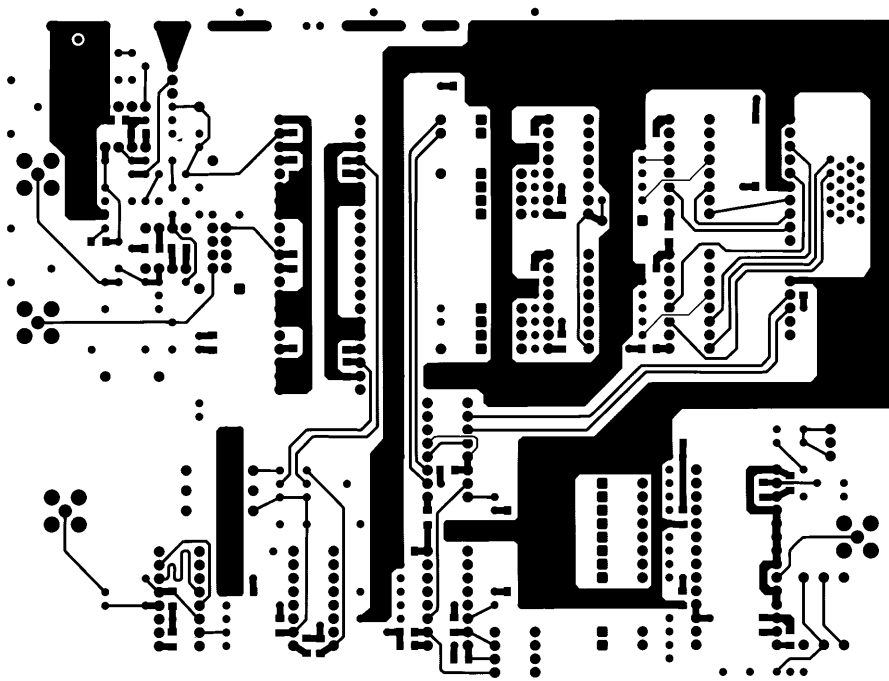

4th layer Solder plane (Top view)

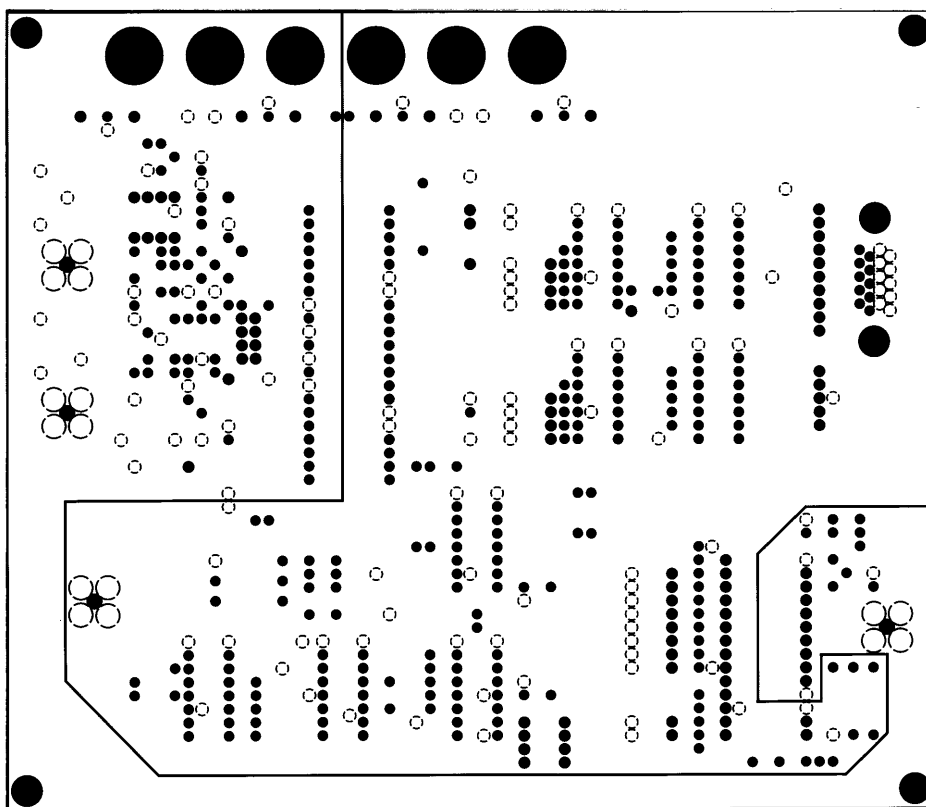

2nd layer GND plane (Top View)

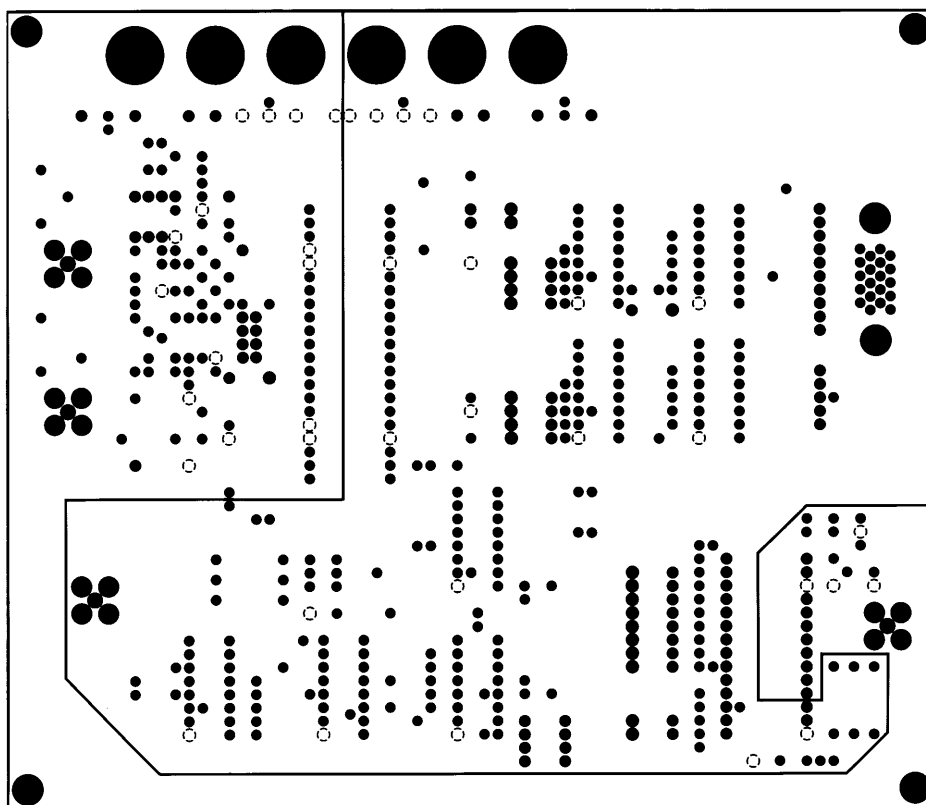

3rd layer Power supply plane (Top View)

This datasheet has been downloaded from:

www.DatasheetCatalog.com

Datasheets for electronic components.



LittleDiode supplies new, hard to find or obsolete electronic components and semiconductors all over the world.

With over two million different components listed you are sure to find the part you need.

Feel free to visit us today at our online store:

LittleDiode.com

Looking forward to providing you with the best possible service.