

8-bit D/A Converter Supporting with I²C Bus

Description

The CXA1315M/P is developed as a 5-channel 8-bit D/A converter supporting with I²C bus.

Features

- Serial control through I²C bus
- 5-channel 8-bit D/A converter
- Built-in 4 general-purpose I/O ports (Digital I/O)
- I/O can be specified to respective ports independently
- Selection of 8 slave addresses possible through address select pins (3 pins)

Applications

The IC, which cannot support I²C bus, can support it by connecting its control pin to the CXA1315M/P.

Structure

Bipolar silicon monolithic IC

Absolute Maximum Ratings (Ta = 25°C)

- | | | | |
|-------------------------------|------------------|-------------|----|
| • Supply voltage | V _{CC} | 12 | V |
| • Operating temperature | T _{opr} | -20 to +75 | °C |
| • Storage temperature | T _{stg} | -65 to +150 | °C |
| • Allowable power dissipation | P _D | 960 | mW |

Operating Conditions

- | | | | |
|-------------------------|------------------|------------|----|
| • Supply voltage | V _{CC} | 8.2 to 9.8 | V |
| • Operating temperature | T _{opr} | -20 to +75 | °C |

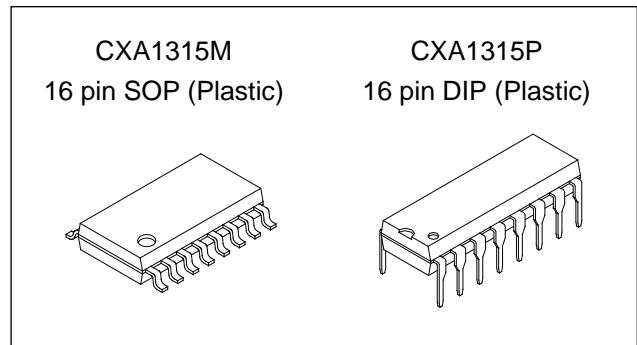

Purchase of Sony's I²C components conveys a license under the Philips I²C Patent Rights to use these components in an I²C system, provided that the system conforms to the I²C Standard Specifications as defined by Philips.

Sony reserves the right to change products and specifications without prior notice. This information does not convey any license by any implication or otherwise under any patents or other right. Application circuits shown, if any, are typical examples illustrating the operation of the devices. Sony cannot assume responsibility for any problems arising out of the use of these circuits.

Pin Configuration (Top View)

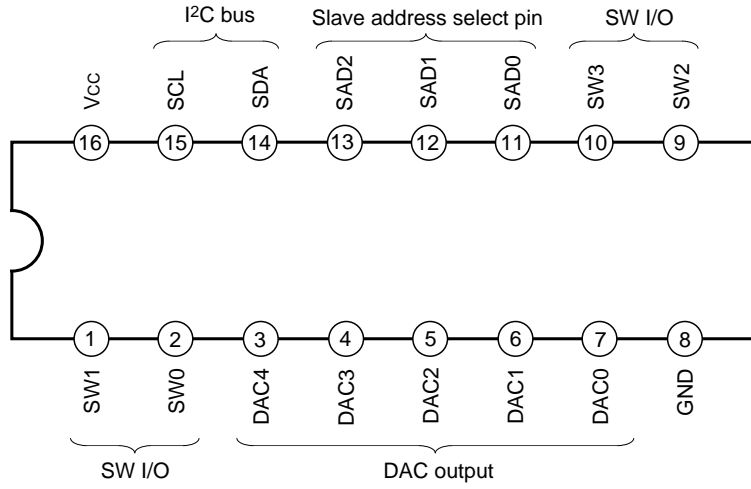

Block Diagram

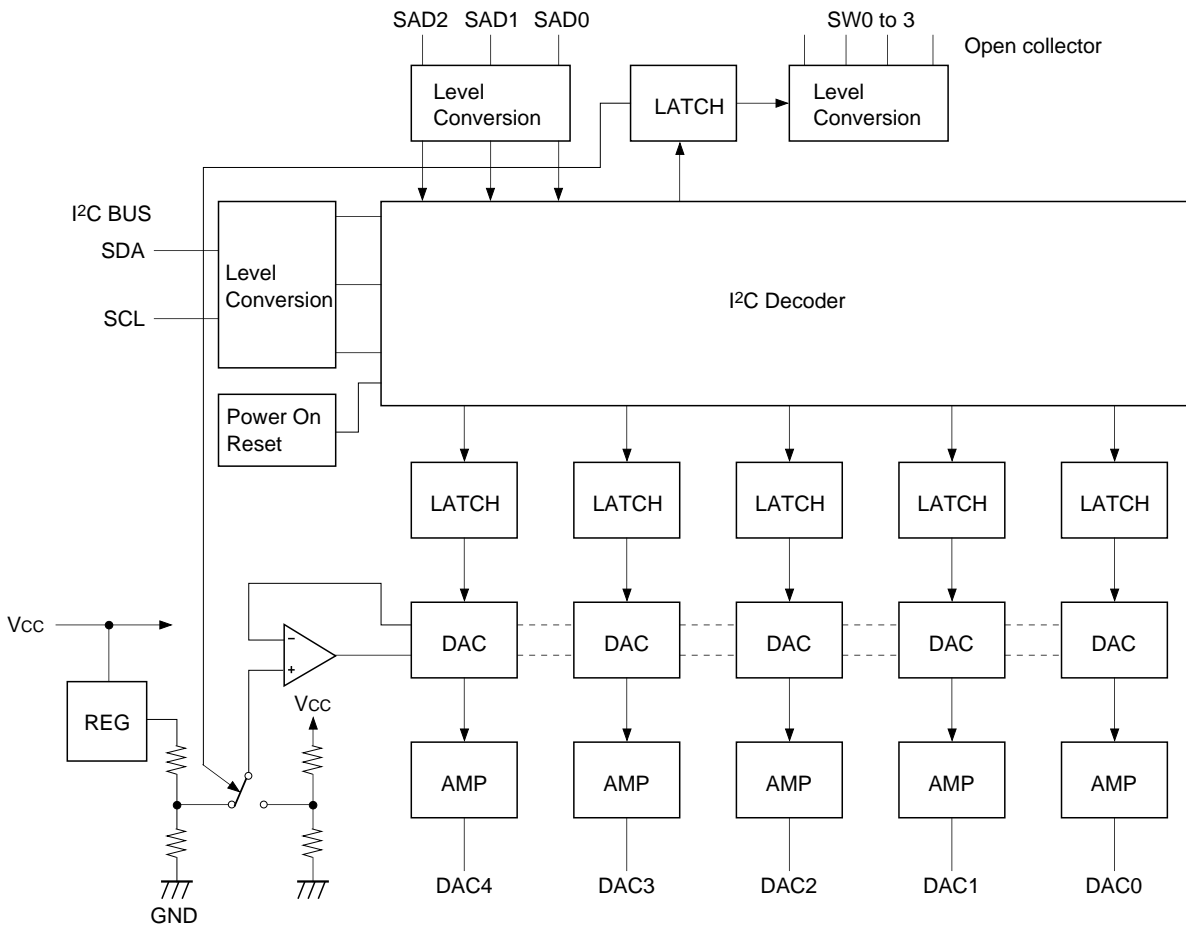

Pin Description

No.	Symbol	Equivalent circuit	Description
1 2 9 10	SW1 SW0 SW2 SW3		I/O pin for genera-purpose I/O port $V_{ILmax}: 1.5V$ $V_{IHmin}: 3V$ $V_{OLmax}: 0.4V$
14	SDA		SDA I/O pin for I ² C bus
3 4 5 6 7	DAC4 DAC3 DAC2 DAC1 DAC0		D/A converter output pin
8	GND		GND pin
11 12 13	SAD0 SAD1 SAD2		Slave address input pin Input at positive logic $V_{ILmax}: 1.5V$ $V_{IHmin}: 3V$
15	SCL		SCL input pin for I ² C bus
16	Vcc		Power supply pin

Electrical Characteristics

(Ta = 25°C, Vcc = 9V)

No.	Item	Symbol	Test circuit	Test conditions	Min.	Typ.	Max.	Unit
1	Circuit current	Icc	1	DAC 0 to 4 = 127	8	11	15	mA

D/A Converter Block

2	Differential linearity	DLE	1	$\frac{V(DAC0 \text{ to } 4 = n + 1) - V(DAC0 \text{ to } 4 = N)}{V(DAC0 \text{ to } 4 = 191) - V(DAC0 \text{ to } 4 = 63)} \times 128 - 1$ n = 0 to 127	-1	0	+1.1	LSB
3	Minimum output voltage	Vmin	1	DAC 0 to 4 = 0	0.1	0.4	0.62	V
4	Maximum output voltage	Vmax	1	DAC 0 to 4 = 255	8.3	8.5	8.9	V
5	Output current	Iout	2	Current that can be flowed from Pins 3 to 7	-1		+1	mA
6	Output impedance	Zo	2	DAC 0 to 4 = 127, $\frac{V(-1mA) - V(1mA)}{2mA}$	0	3	6	Ω
7	Reple rejection	Grip	3	DAC 0 to 4 = 127, REF = 0 Superimose 100Hz to Vcc, 1Vp-p	—	-60	-40	dB

SW, SAD Pins

No.	Item	Symbol	Test circuit	Test conditions	Min.	Typ.	Max.	Unit
8	Low level input voltage	V_{IL}	4	Input voltage where ST0 to ST3 become "0"	—	—	1.5	V
8	High level input voltage	V_{IH}	4	Input voltage where ST0 to ST3 become "1"	3.0	—	—	V
9	Low level input current	I_{IL}	4	Input current when 0.4V is applied	-10	0	+10	μ A
10	High level input current	I_{IH}	4	Input current when 4.5V is applied	-10	0	+10	μ A
11	Low level input voltage	V_{OL}	5	SW 0 to 3 = 1, Output voltage when 1mA flows in	0	0.2	0.4	V

I²C Bus Block Items (SDA, SCL)

No.	Item	Symbol	Min.	Typ.	Max.	Unit
13	High level input voltage	V_{IH}	3.0	—	5.0	V
14	Low level input voltage	V_{IL}	0	—	1.5	V
15	High level input current	I_{IH}	—	—	10	μ A
16	Low level input current	I_{IL}	—	—	10	μ A
17	Low level output voltage, at 3mA flow to SDA (Pin 14)	V_{OL}	0	—	0.4	V
18	Maximum flowing current	I_{OL}	3	—	—	mA
19	Input capacitance	C_i	—	—	10	pF
20	Maximum clock frequency	f_{SCL}	0	—	100	kHz
21	Data change minimum waiting time	t_{BUF}	4.7	—	—	μ s
22	Data transfer start minimum waiting time	$t_{HD; STA}$	4.0	—	—	μ s
23	Low level clock pulse width	t_{LOW}	4.7	—	—	μ s
24	High level clock pulse width	t_{HIGH}	4.0	—	—	μ s
25	Minimum start preparation waiting time	$t_{SU; STA}$	4.7	—	—	μ s
26	Minimum data hold time	$t_{HD; DAT}$	5	—	—	μ s
27	Minimum data preparation time	$t_{SU; DAT}$	250	—	—	ns
28	Rise time	t_R	—	—	1	μ s
29	Fall time	t_F	—	—	300	ns
30	Minimum stop preparation waiting time	$t_{SU; STO}$	4.7	—	—	μ s

I²C bus load conditions: Pull-up resistance 4k Ω (Connected to +5V)
 Load capacitance 200pF (Connected to GND)

I²C Bus Control Signal

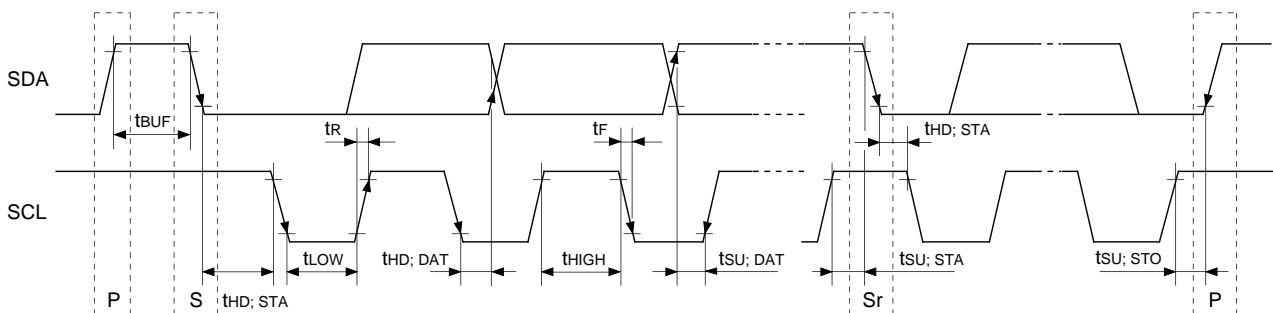

Electrical Characteristics Measurement Circuit

Measurement Circuit 1

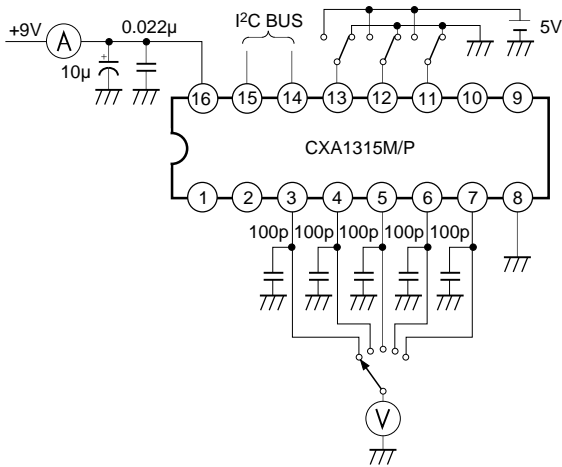

Measurement Circuit 2

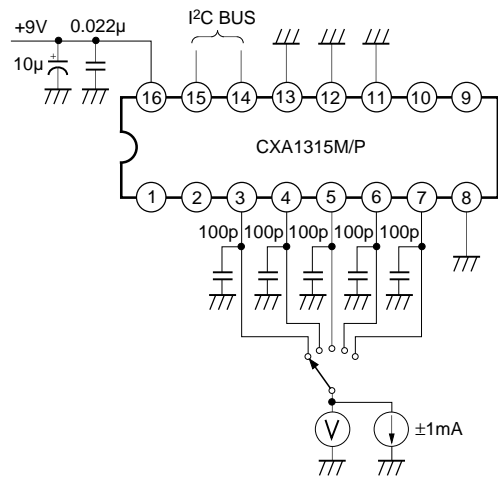

Measurement Circuit 3

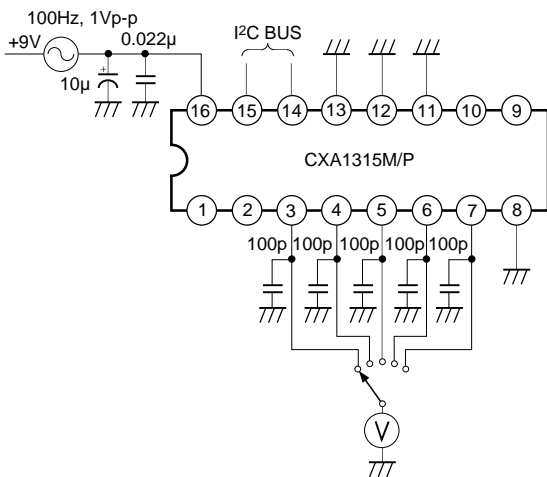

Measurement Circuit 4

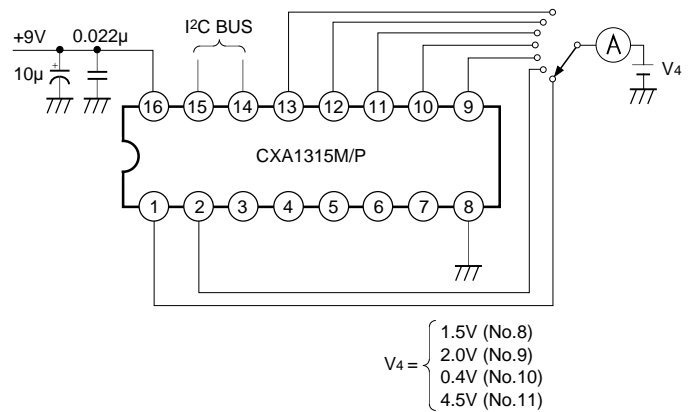

Measurement Circuit 5

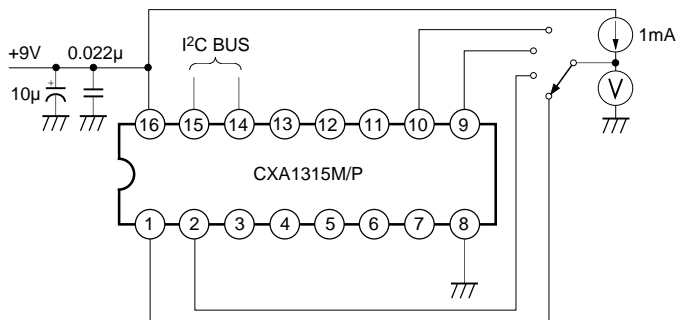

<Registers> In brackets () number of bits

- REF (1): Switches D/A converter reference voltage
 0: Standardizes the inner regulator
 1: Standardizes voltage resistance divided from Vcc
- SW0 to 3 (1): Selects ON/OFF of Pins 1, 2, 9 and 10
 (Each pin is the open collector output of NPN transistor)
 0: OFF
 1: ON
- DAC0 to 4 (8): Digital data input register of D/A converter
 0: Output voltage turns to minimum
 255: Output voltage turns to maximum
- PONRES (1): Detects POWER ON RESET
 0: Master passes from the bus and is reset to "0" after having read this status
 1: Sets to "1" when power supply is turned on or when there has been a power dip
- ST0 to 3 (1): Detects and registers the voltage condition of Pins 1, 2, 9 and 10
 0: 1.5V and below
 1: 3.0V and above
Note) SW0 to 3 effective during "0"

I²C Bus Signal

There are 2 signals in I²C bus. SDA (Serial Data) and SCL (Serial Clock).

SDA is double-way.

- As SDA is bidirectional it has 3 state outputs, H, L and Hi-Z.

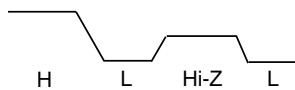

- I²C transfer begins with Start Condition S and ends with Stop Condition P.

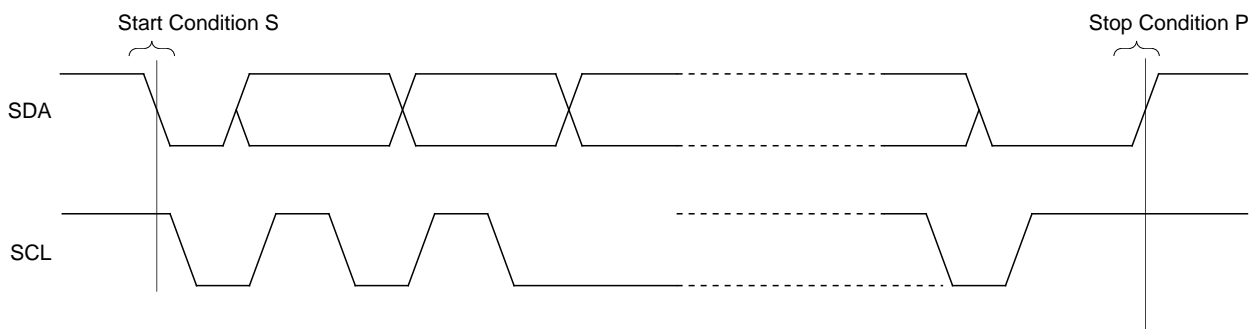

• I²C data write (Write from I²C controller to IC)

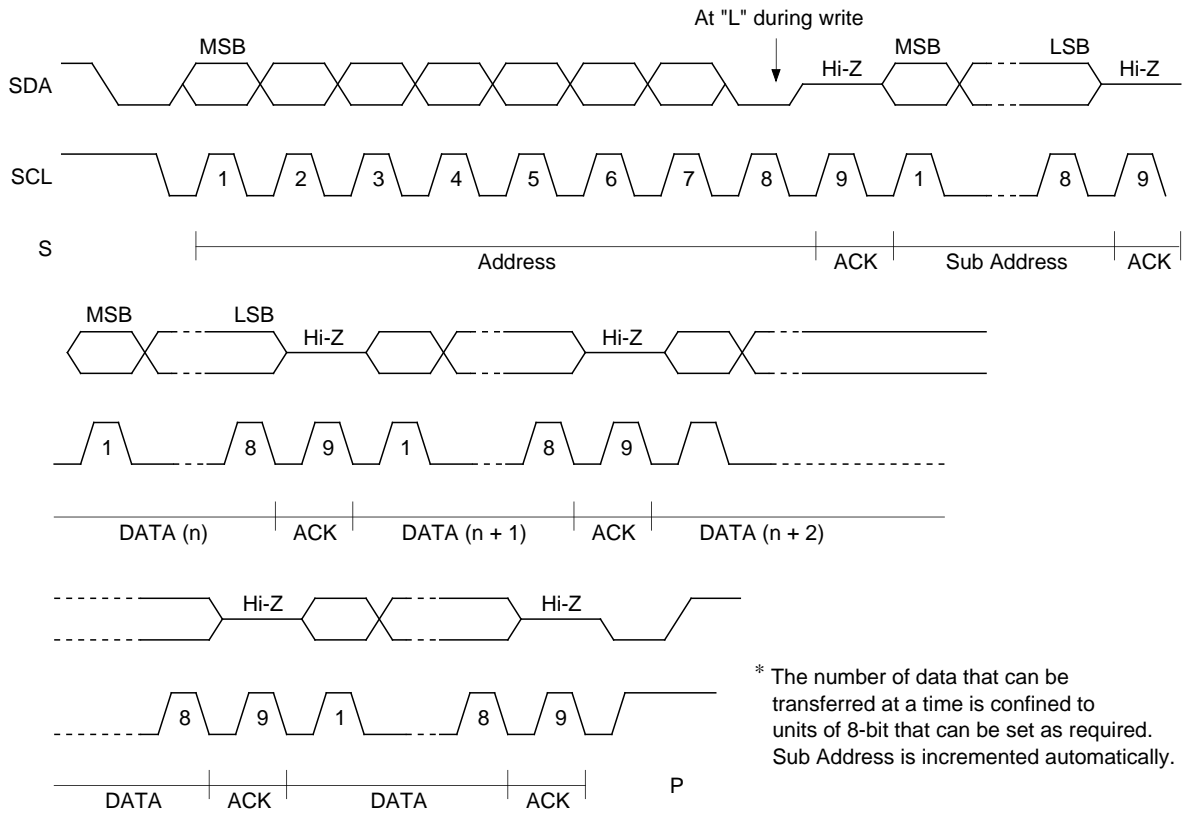

• I²C data read (Read from IC to I²C controller)

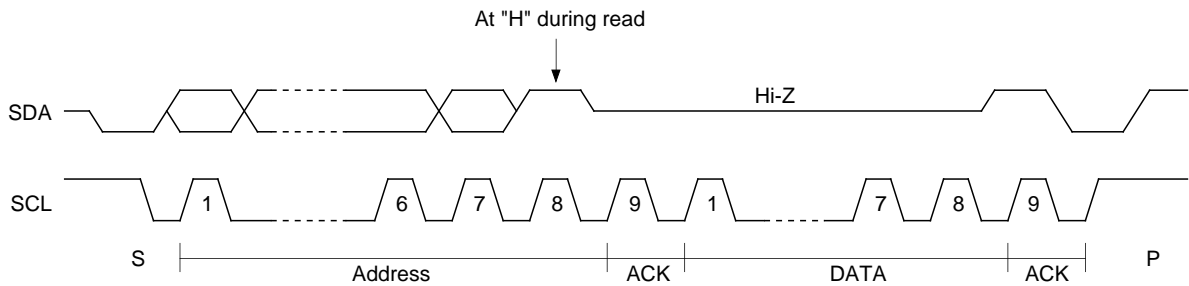

• Read timing

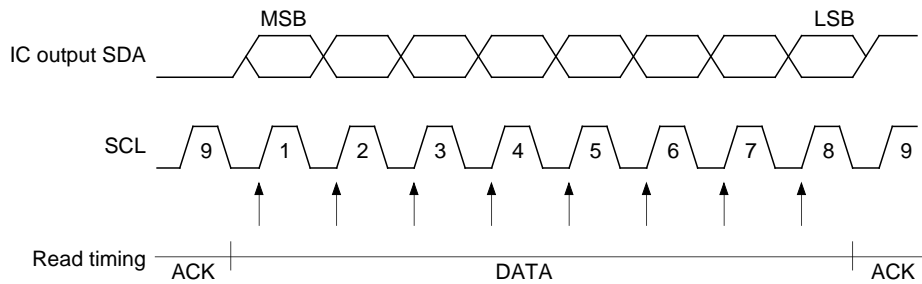

* Data read is performed with SCL rise.

Application Circuit

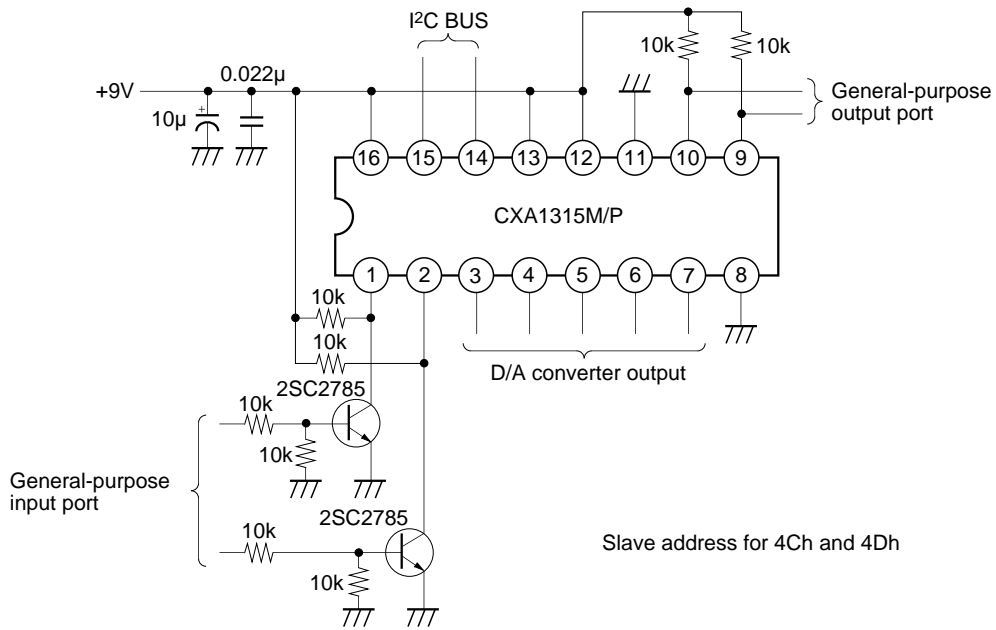

Application circuits shown are typical examples illustrating the operation of the devices. Sony cannot assume responsibility for any problems arising out of the use of these circuits or for any infringement of third party patent and other right due to same.

Characteristics Diagram

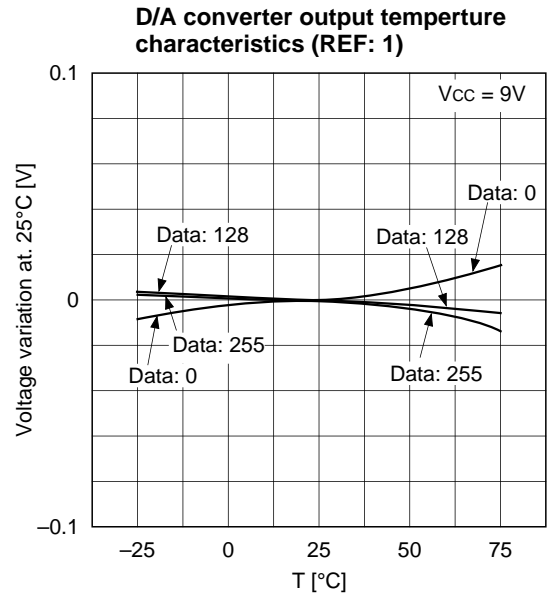
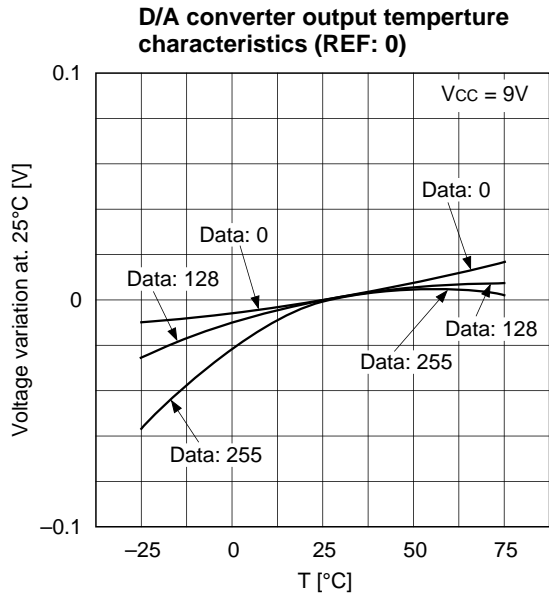

Package Outline Unit: mm

CXA1315M

16PIN SOP (PLASTIC)

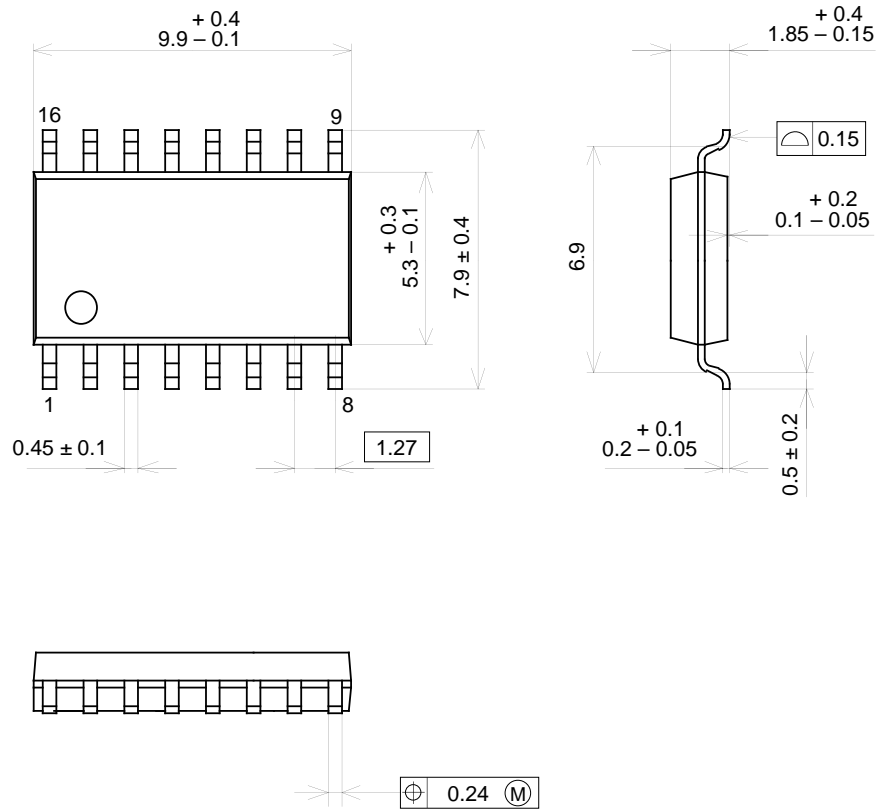

PACKAGE STRUCTURE

SONY CODE	SOP-16P-L01
EIAJ CODE	SOP016-P-0300
JEDEC CODE	_____

PACKAGE MATERIAL	EPOXY RESIN
LEAD TREATMENT	SOLDER PLATING
LEAD MATERIAL	COPPER ALLOY
PACKAGE MASS	0.2g

CXA1315P

16PIN DIP (PLASTIC)

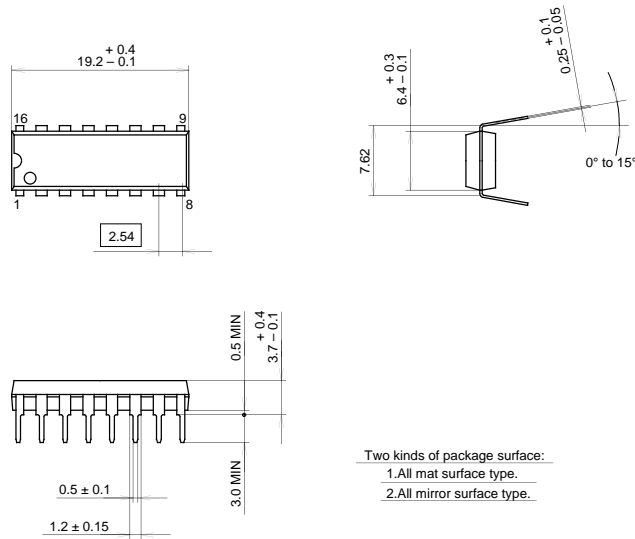

Two kinds of package surface:
 1. All mat surface type.
 2. All mirror surface type.

SONY CODE	DIP-16P-01
EIAJ CODE	DIP016-P-0300
JEDEC CODE	Similar to MO-001-AE

PACKAGE STRUCTURE

PACKAGE MATERIAL	EPOXY RESIN
LEAD TREATMENT	SOLDER PLATING
LEAD MATERIAL	COPPER ALLOY
PACKAGE MASS	1.0 g

16PIN DIP (PLASTIC) 300mil

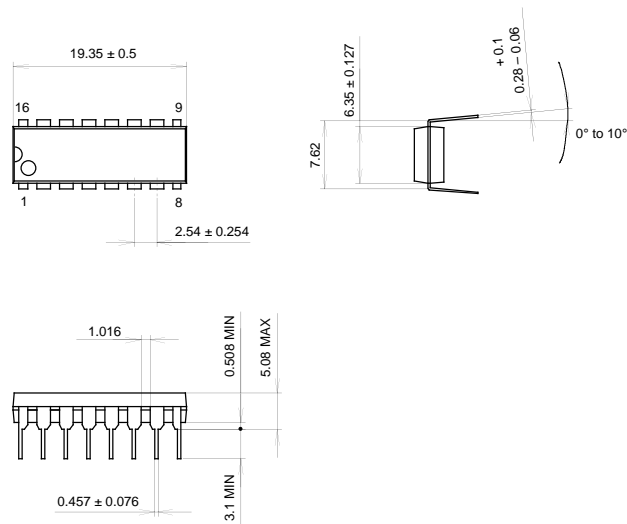

SONY CODE	DIP-16P-191
EIAJ CODE	DIP016-P-0300-AU
JEDEC CODE	MS-001-AA

PACKAGE STRUCTURE

PACKAGE MATERIAL	EPOXY RESIN
LEAD TREATMENT	SOLDER PLATING
LEAD MATERIAL	COPPER
PACKAGE WEIGHT	1.0g

This datasheet has been downloaded from:

www.DatasheetCatalog.com

Datasheets for electronic components.



LittleDiode supplies new, hard to find or obsolete electronic components and semiconductors all over the world.

With over two million different components listed you are sure to find the part you need.

Feel free to visit us today at our online store:

LittleDiode.com

Looking forward to providing you with the best possible service.