

# CR3AMZ

LOW POWER, STROBE USE  
NON-INSULATED TYPE, GLASS PASSIVATION TYPE

**CR3AMZ**



- $I_T (AV)$  ..... **0.4A**
- $V_{DRM}$  ..... **400V**
- $I_{GT}$  ..... **30mA**

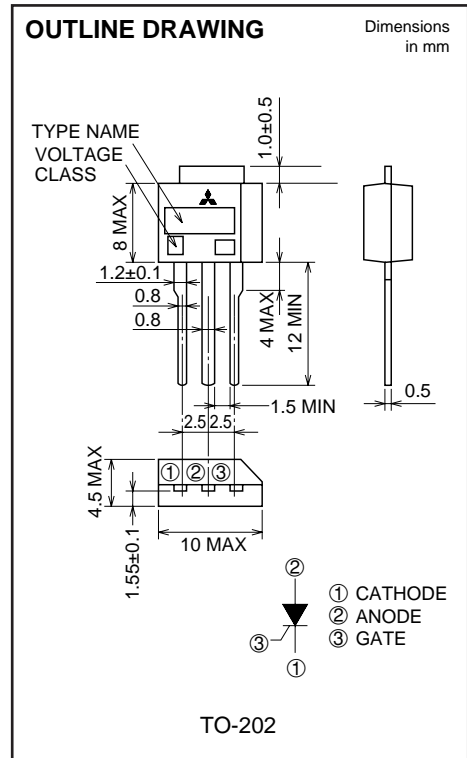

## APPLICATION

Automatic strobe flasher

## MAXIMUM RATINGS

Symbol	Parameter	Voltage class		Unit
		8		
VRRM	Repetitive peak reverse voltage	400		V
VRSM	Non-repetitive peak reverse voltage	480		V
VDRM	Repetitive peak off-state voltage	400		V
VDSM	Non-repetitive peak off-state voltage	480		V

Symbol	Parameter	Conditions	Ratings	Unit
$I_T (AV)$	Average on-state current	Commercial frequency, sine half wave, 180° conduction,	0.4	A
$I_{TRM}$	Repetitive peak on-state current *1	$C_M=700\mu F$ with discharge current	200	A
PGM	Peak gate power dissipation		0.5	W
PG (AV)	Average gate power dissipation		0.1	W
VFGM	Peak gate forward voltage		6	V
IFGM	Peak gate forward current		0.5	A
$T_j$	Junction temperature		-40 ~ +125	°C
$T_{stg}$	Storage temperature		-40 ~ +125	°C
—	Weight	Typical value	1.1	g

\*1. Refer to sections 1, 2 on STROBE FLASHER APPLICATION shown in the last sheet for CR3JM.

# CR3AMZ

LOW POWER, STROBE USE  
NON-INSULATED TYPE, GLASS PASSIVATION TYPE

## ELECTRICAL CHARACTERISTICS

Symbol	Parameter	Test conditions	Limits			Unit
			Min.	Typ.	Max.	
IRRM	Repetitive peak reverse current	$T_j=25^\circ\text{C}$ , $V_{RRM}$ applied	—	—	0.1	mA
IDRM	Repetitive peak off-state current	$T_j=25^\circ\text{C}$ , $V_{DRM}$ applied	—	—	0.1	mA
V <sub>TM</sub>	On-state voltage	$T_a=25^\circ\text{C}$ , $I_{TM}=3\text{A}$ , Instantaneous value	—	—	2.0	V
V <sub>GT</sub>	Gate trigger voltage	$T_j=25^\circ\text{C}$ , $V_D=6\text{V}$ , $R_L=6\Omega$	—	—	1.5	V
V <sub>GD</sub>	Gate non-trigger voltage	$T_j=125^\circ\text{C}$ , $V_D=1/2V_{DRM}$	0.1	—	—	V
I <sub>GT</sub>	Gate trigger current	$T_j=25^\circ\text{C}$ , $V_D=6\text{V}$ , $R_L=6\Omega$	—	—	30	mA
C <sub>c</sub>	Commutating capacitor *2	$C_M=700\mu\text{F}$ , $V_{CM}=350\text{V}$ , $I_{TM}=200\text{A}$ , $L=25\mu\text{H}$ , $T_a=25^\circ\text{C}$	—	—	2.2	$\mu\text{F}$

\*2. Refer to section 3 on STROBE FLASHER APPLICATION shown in the last sheet for CR3JM.

Fig 1. TEST CIRCUIT FOR COMMUTATING CAPACITOR

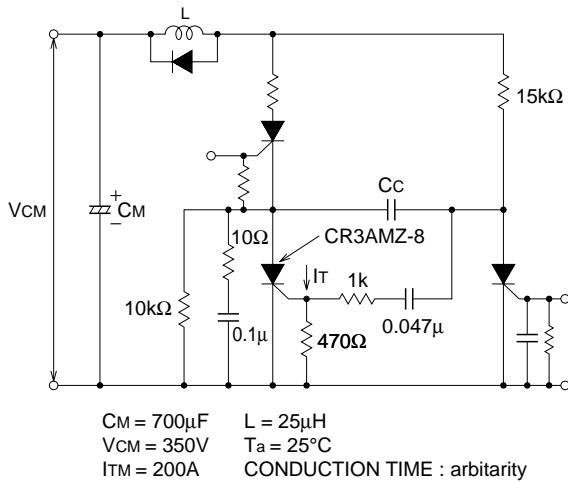

## PERFORMANCE CURVES

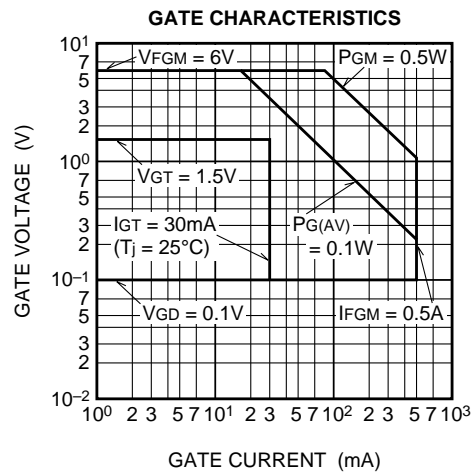
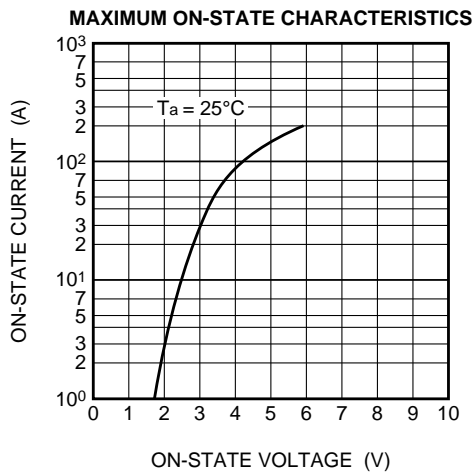

# CR3AMZ

LOW POWER, STROBE USE  
NON-INSULATED TYPE, GLASS PASSIVATION TYPE

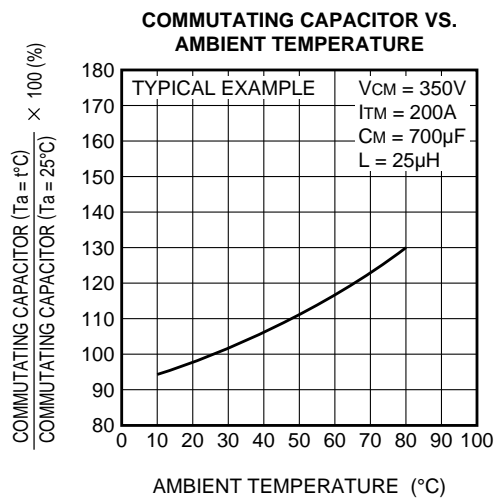
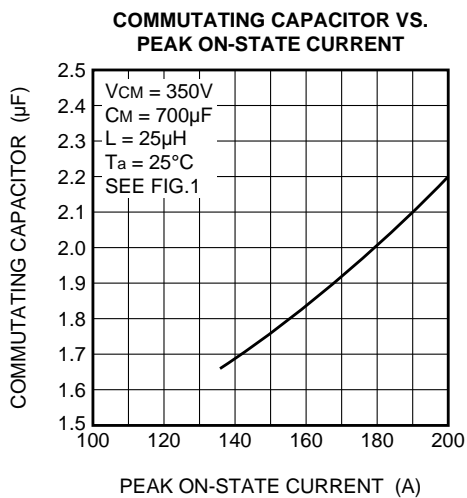
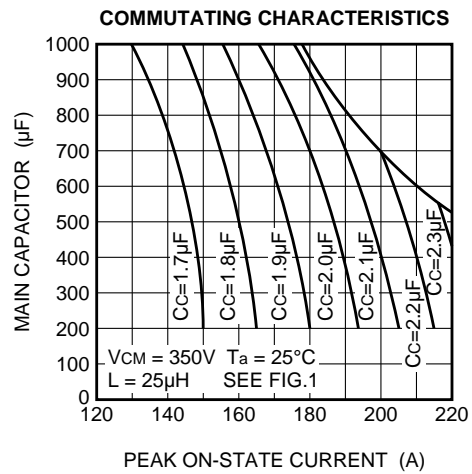
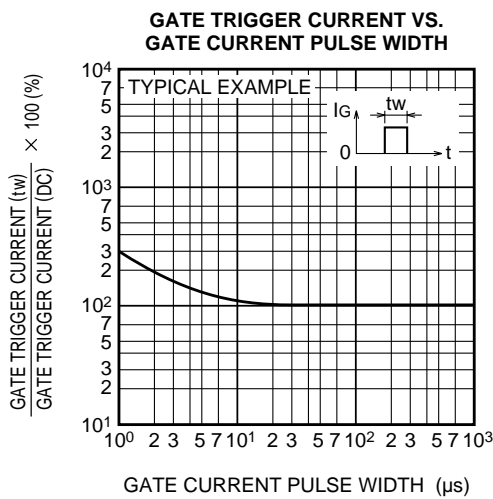
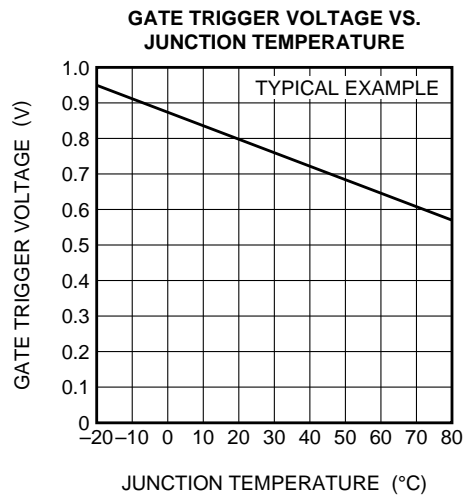
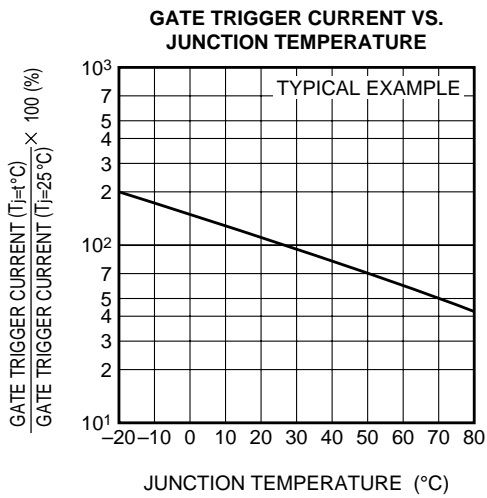

# CR3AMZ

LOW POWER, STROBE USE  
NON-INSULATED TYPE, GLASS PASSIVATION TYPE

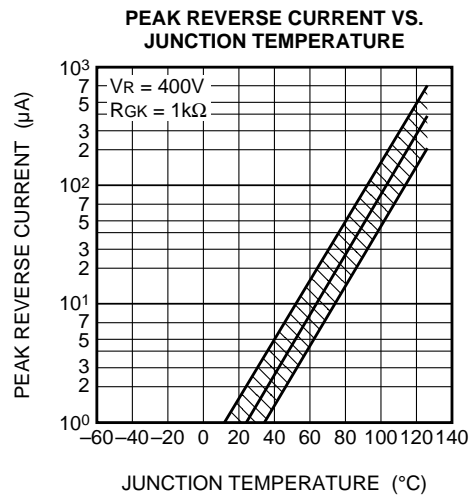
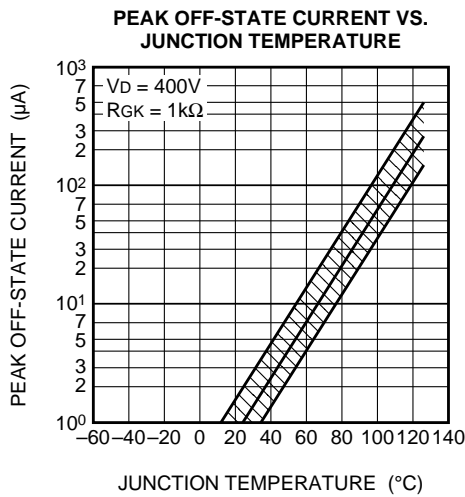
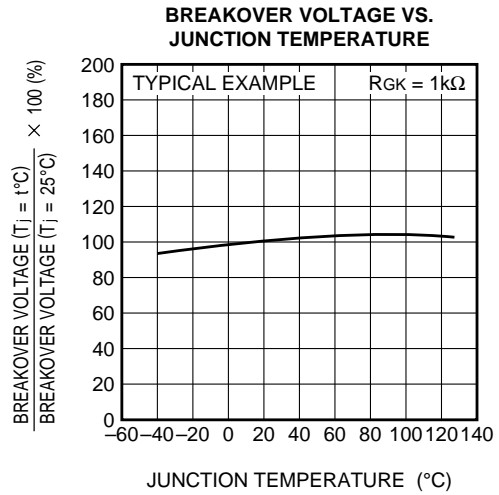
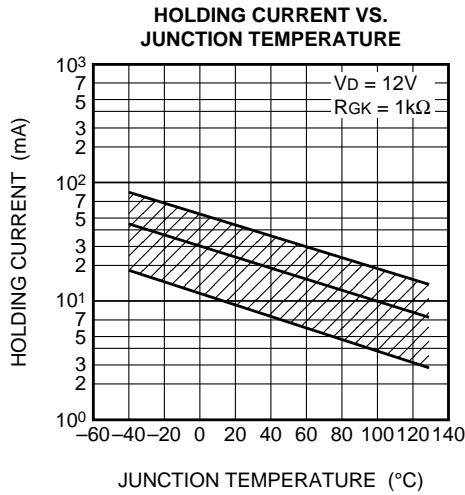



LittleDiode supplies new, hard to find or obsolete electronic components and semiconductors all over the world.

With over two million different components listed you are sure to find the part you need.

Feel free to visit us today at our online store:

[LittleDiode.com](http://LittleDiode.com)

Looking forward to providing you with the best possible service.