



T-25-19

**C380\_\_X500**

Powerex, Inc. Hillis Street, Youngwood, Pennsylvania 15697 (412) 925-7272  
 Powerex Europe, S.A., 428 Ave. G. Durand, BP107, 72003 LeMans, France (43) 72.75.15

**Phase Control SCR**  
**310 Amperes Avg**  
**800 Volts**

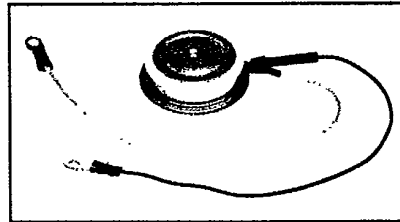
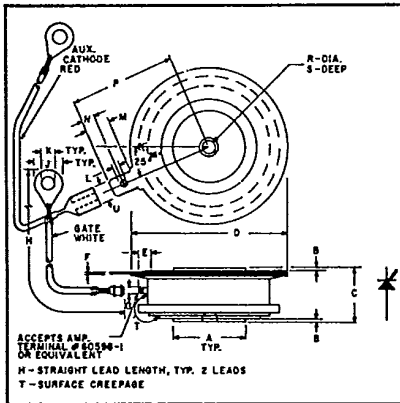

**C380\_\_X500**  
**Phase Control SCR**  
 310 Amperes/800 Volts

**Description**

Powerex Silicon Controlled Rectifiers (SCR) are designed for phase control applications. These are all-diffused, Press-Pak (Pow-R-Disc) devices employing the field-proven amplifying (di/namic) gate.

**Features:**

- Low On-State Voltage
- High di/dt
- High dv/dt
- Hermetic Packaging
- Excellent Surge and I<sup>2</sup>t Ratings

**Applications:**

- Power Supplies
- Battery Chargers
- Motor Control
- Light Dimmers
- VAR Generators

**Ordering Information**

Example: Select the complete nine digit part number you desire from the table - i.e. C380MX500 is a 600 Volt, 310 Ampere Phase Control SCR.

**C380\_\_X500**  
**Outline Drawing**

Dimensions	Inches		Millimeters	
	Min.	Max.	Min.	Max.
A	.744	.752	18.897	19.101
B	.030	.060	.762	1.524
C	.515	.565	13.081	14.351
D	1.600	1.656	40.64	42.06
E	.110	—	2.794	—
F	.013	.017	.330	.432
G	.057	.059	1.447	1.449
H	7.980	8.115	202.70	206.11
J	—	.300	—	7.620
K	.137	.153	3.479	3.886
L	.065	.070	1.651	1.778
M	.245	.260	6.223	6.604
N	.120	.140	3.048	3.556
P	1.090	1.125	27.69	28.55
R	.135	.145	3.429	3.683
S	.067	.083	1.701	2.108
T	.340	—	8.636	—
U	.186	.189	4.724	4.801

Type	Voltage		Current
	V <sub>ORM</sub> V <sub>RRM</sub>	Code	
C380__X500	100	A	310
	200	B	
	300	C	
	400	D	
	500	E	
	600	M	
	700	S	
	800	N	



Powerex, Inc., Hillis Street, Youngwood, Pennsylvania 15697 (412) 925-7272  
 Powerex Europe, S.A., 428 Ave. G. Durand, BP107, 72003 LeMans, France (43) 72.75.15

C380\_X500  
 Phase Control SCR  
 310 Amperes Avg/800 Volts

### Absolute Maximum Ratings

	Symbol	C380_X500	Units
RMS On-State Current	$I_{T(RMS)}$	500	Amperes
Average On-State Current	$I_{T(av)}$	310	Amperes
Peak One-Cycle Surge (Non-Repetitive) On-State Current (60Hz)	$I_{TSM}$	5500	Amperes
Peak One-Cycle Surge (Non-Repetitive) On-State Current (50Hz)	$I_{TSM}$	5000	Amperes
Critical Rate-of-Rise of On-State Current (Non-Repetitive)	di/dt	800	Amperes/ $\mu$ s
Critical Rate-of-Rise of On-State Current (Repetitive)	di/dt	500	Amperes/ $\mu$ s
$I^2t$ (for Fusing), One Cycle at 60Hz	$I^2t$	125,000	A <sup>2</sup> sec
Peak Gate Power Dissipation	$P_{GM}$	10	Watts
Average Gate Power Dissipation	$P_{G(av)}$	2	Watts
Storage Temperature	$T_{STG}$	-40 to 150	°C
Operating Temperature	$T_J$	-40 to 125	°C
Mounting Force <sup>Ⓞ</sup>		720 to 880	lb.
Mounting Force <sup>Ⓞ</sup>		3.2 to 3.92	kN

### Electrical and Thermal Characteristics

Characteristics	Symbol	Test Conditions	C380_X500	Units
<b>Voltage—Blocking State Maximums</b>				
Forward Leakage, Peak	$I_{DRM}$	$T_J = 125^\circ\text{C}, V = V_{DRM}$	20	mA
Reverse Leakage, Peak	$I_{RRM}$	$T_J = 125^\circ\text{C}, V = V_{RRM}$	20	mA
<b>Current—Conducting State Maximums</b>				
Peak On-State Voltage	$V_{TM}$	$T_C = 125^\circ\text{C}, I_{TM} = 1500\text{A}, \text{Duty Cycle} = 0.01\%$	1.75	Volts
<b>Switching</b>				
Typical Turn-On Delay	$t_d$	$T_C = 25^\circ\text{C}, I_T = 100\text{A}, V_{DRM} = \text{rated.}$ Gate Supply 10V Open Circuit, 25 $\Omega$ , 0.1 $\mu$ sec max. rise time	1	$\mu$ sec
Min. Critical dv/dt exponential to $V_{DRM}$	dv/dt	$T_J = 125^\circ\text{C}, \text{Gate open circuited.}$	200	V/ $\mu$ sec
<b>Thermal</b>				
Maximum Thermal Resistance, <sup>Ⓞ</sup> double sided cooling Junction to Case	$R_{\theta JC}$		0.095	°C/Watt
Case to Sink, Lubricated	$R_{\theta CS}$		.02	°C/Watt
<b>Gate—Maximum Parameters</b>				
Gate Current to Trigger	$I_{GT}$	$T_C = 25^\circ\text{C}, V_D = 6\text{V}, R_L = 3 \Omega$	150	mA
Gate Voltage to Trigger	$V_{GT}$	$T_C = -40^\circ\text{C} \text{ to } 125^\circ\text{C}, V_D = 6\text{V}, R_L = 3 \Omega$	3.0	Volts
Non-Trigging Gate Voltage	$V_{GDM}$	$T_J = 125^\circ\text{C}, \text{Rated } V_{DRM}, R_L = 1000 \Omega$	.15	Volts
Peak Forward Gate Current	$I_{GTM}$		10	Amperes
Peak Reverse Gate Voltage	$V_{GRM}$		5	Volts

<sup>Ⓞ</sup> Consult recommended mounting procedures.



Powerex, Inc., Hillis Street, Youngwood, Pennsylvania 15697 (412) 925-7272  
 Powerex Europe, S.A., 428 Ave. G. Durand, BP107, 72003 LeMans, France (43) 72.75.15

C380\_X500  
 Phase Control SCR  
 310 Amperes Avg/800 Volts

MAXIMUM ON-STATE CHARACTERISTICS

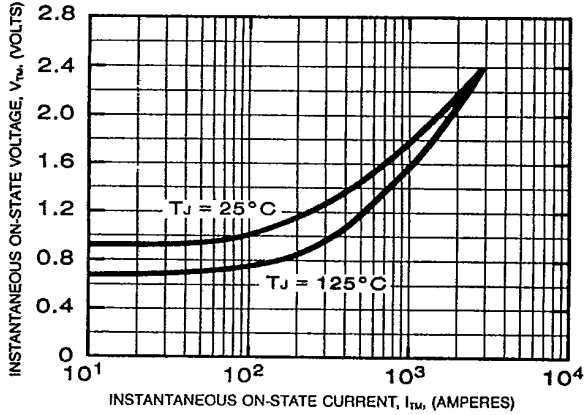

TRANSIENT THERMAL IMPEDANCE CHARACTERISTICS (JUNCTION TO CASE)

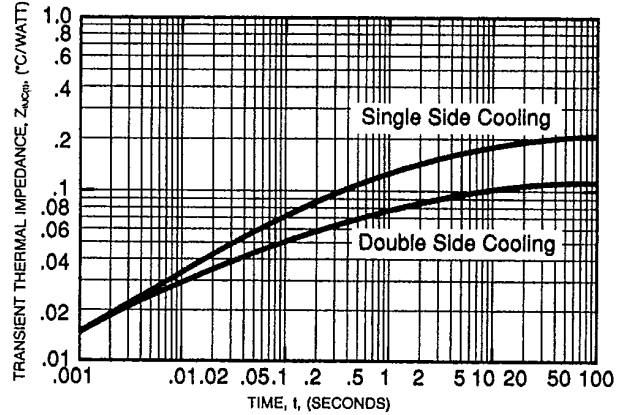

MAXIMUM ALLOWABLE CASE TEMPERATURE (SINUSOIDAL WAVEFORM)

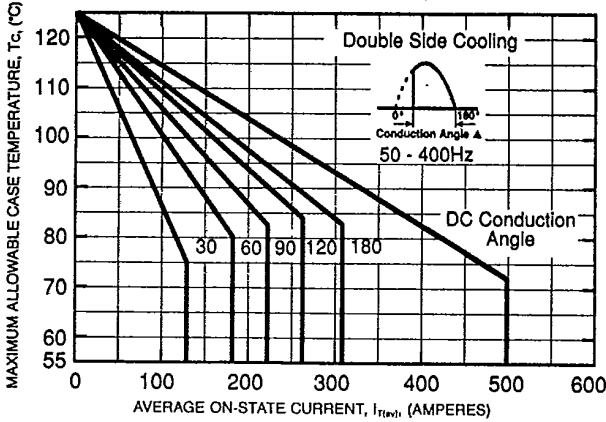

MAXIMUM ON-STATE POWER DISSIPATION (SINUSOIDAL WAVEFORM)

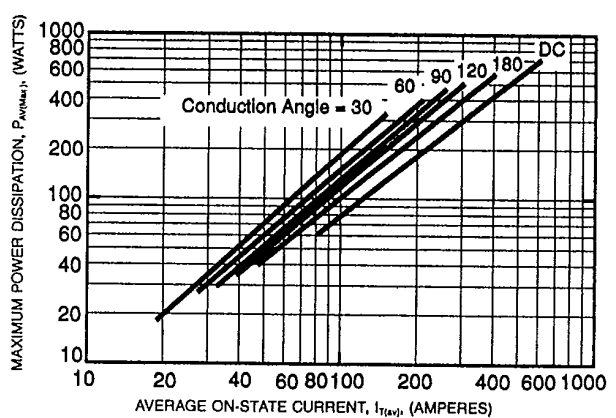

MAXIMUM ALLOWABLE CASE TEMPERATURE (RECTANGULAR WAVEFORM)

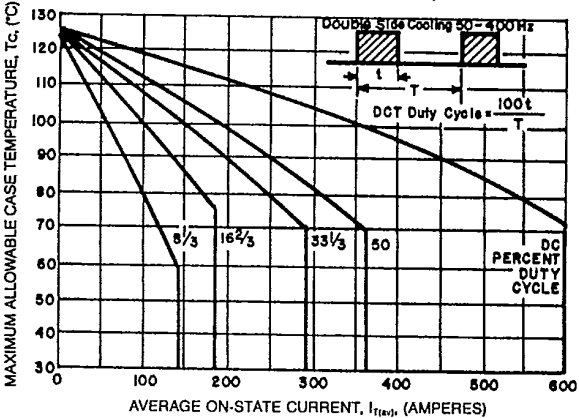

MAXIMUM ON-STATE POWER DISSIPATION (RECTANGULAR WAVEFORM)

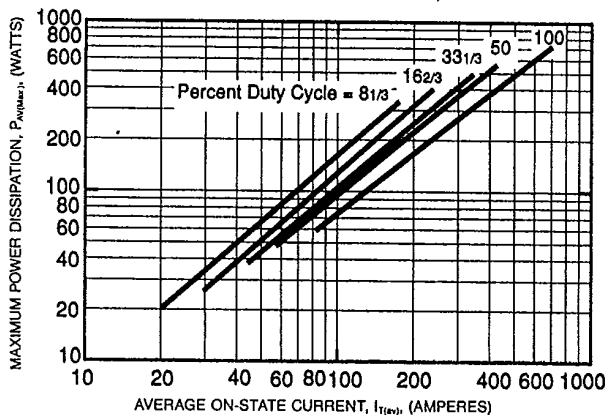



Powerex, Inc., Hillis Street, Youngwood, Pennsylvania 15697 (412) 925-7272  
 Powerex Europe, S.A., 428 Ave. G. Durand, BP107, 72003 LeMans, France (43) 72.75.15

C380...X500  
 Phase Control SCR  
 310 Amperes Avg/800 Volts

SUB-CYCLE SURGE AND I<sup>2</sup>t RATINGS  
 (RATED LOAD CONDITIONS)

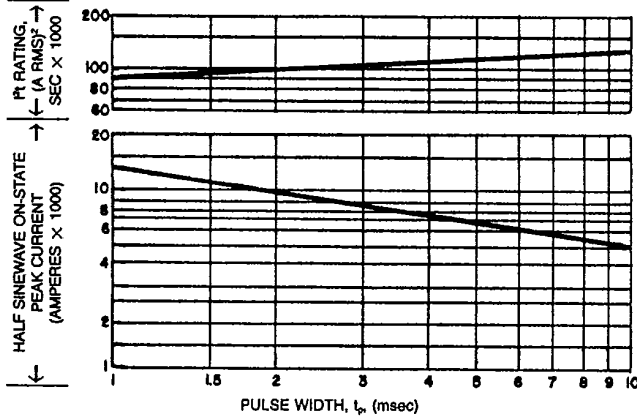

GATE CHARACTERISTICS

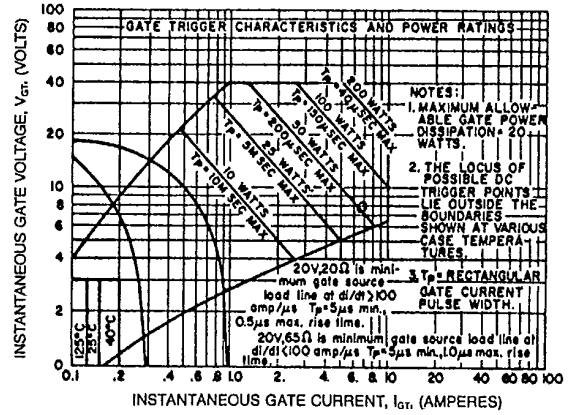

- NOTES:
1. Maximum allowable gate power dissipation = 20 watts.
  2. The locus of possible DC trigger points lie outside the boundaries shown at various case temperatures.
  3. T<sub>p</sub> = Rectangular Gate Current Pulse Width.



LittleDiode supplies new, hard to find or obsolete electronic components and semiconductors all over the world.

With over two million different components listed you are sure to find the part you need.

Feel free to visit us today at our online store:

[LittleDiode.com](http://LittleDiode.com)

Looking forward to providing you with the best possible service.