

PNP Silicon Switching Transistors

- High DC current gain: 0.1mA to 500 mA
- Low collector-emitter saturation voltage
- Complementary types: BSS79, BSS81 (NPN)

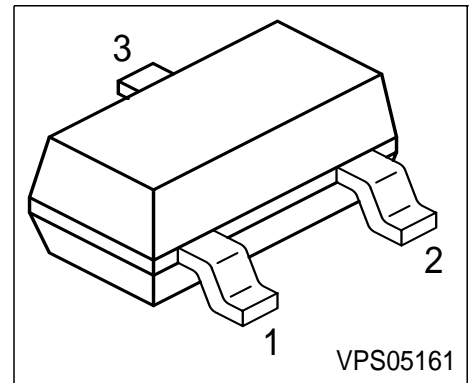

Type	Marking	Pin Configuration			Package
BSS80B	CHs	1 = B	2 = E	3 = C	SOT23
BSS80C	CJs	1 = B	2 = E	3 = C	SOT23
BSS82B	CLs	1 = B	2 = E	3 = C	SOT23
BSS82C	CMs	1 = B	2 = E	3 = C	SOT23

Maximum Ratings

Parameter	Symbol	BSS80	BSS82	Unit
Collector-emitter voltage	V_{CEO}	40	60	V
Collector-base voltage	V_{CBO}	60		V
Emitter-base voltage	V_{EBO}	5		
DC collector current	I_C	800		mA
Peak collector current	I_{CM}	1		A
Base current	I_B	100		mA
Peak base current	I_{BM}	200		
Total power dissipation, $T_S = 77\text{ °C}$	P_{tot}	330		mW
Junction temperature	T_j	150		°C
Storage temperature	T_{stg}	-65 ... 150		

Thermal Resistance

Junction - soldering point ¹⁾	R_{thJS}	≤220	K/W
--	------------	------	-----

¹⁾For calculation of R_{thJA} please refer to Application Note Thermal Resistance

Electrical Characteristics at $T_A = 25^\circ\text{C}$, unless otherwise specified.

Parameter	Symbol	Values			Unit		
		min.	typ.	max.			
DC Characteristics							
Collector-emitter breakdown voltage $I_C = 10\text{ mA}, I_B = 0$	$V_{(BR)CEO}$				V		
BSS80		40	-	-			
BSS82		60	-	-			
Collector-base breakdown voltage $I_C = 10\text{ }\mu\text{A}, I_E = 0$	$V_{(BR)CBO}$	60	-	-			
Emitter-base breakdown voltage $I_E = 10\text{ }\mu\text{A}, I_C = 0$	$V_{(BR)EBO}$	5	-	-			
Collector cutoff current $V_{CB} = 50\text{ V}, I_E = 0$	I_{CBO}	-	-	10	nA		
Collector cutoff current $V_{CB} = 50\text{ V}, I_E = 0, T_A = 150\text{ }^\circ\text{C}$	I_{CBO}	-	-	10	μA		
Emitter cutoff current $V_{EB} = 3\text{ V}, I_C = 0$	I_{EBO}	-	-	10	nA		
DC current gain 1) $I_C = 100\text{ }\mu\text{A}, V_{CE} = 10\text{ V}$	h_{FE}	BSS80/82B	40	-	-	-	
		BSS80/82C	75	-	-		
$I_C = 1\text{ mA}, V_{CE} = 10\text{ V}$		BSS80/82B	40	-	-		
		BSS80/82C	100	-	-		
$I_C = 10\text{ mA}, V_{CE} = 10\text{ V}$		BSS80/82B	40	-	-		
		BSS80/82C	100	-	-		
$I_C = 150\text{ mA}, V_{CE} = 10\text{ V}$		BSS80/82B	40	-	120		
		BSS80/82C	100	-	300		
$I_C = 500\text{ mA}, V_{CE} = 10\text{ V}$		BSS80/82B	40	-	-		
		BSS80/82C	50	-	-		
Collector-emitter saturation voltage1) $I_C = 150\text{ mA}, I_B = 15\text{ mA}$ $I_C = 500\text{ mA}, I_B = 50\text{ mA}$		V_{CEsat}					V
			-	-	0.4		
		-	-	1.6			
Base-emitter saturation voltage 1) $I_C = 150\text{ mA}, I_B = 15\text{ mA}$ $I_C = 500\text{ mA}, I_B = 50\text{ mA}$	V_{BEsat}						
		-	-	1.3			
		-	-	2.6			

 1) Pulse test: $t \leq 300\mu\text{s}$, $D = 2\%$

Electrical Characteristics at $T_A = 25^\circ\text{C}$, unless otherwise specified.

Parameter	Symbol	Values			Unit
		min.	typ.	max.	
AC Characteristics					
Transition frequency $I_C = 20\text{ mA}$, $V_{CE} = 20\text{ V}$, $f = 100\text{ MHz}$	f_T	-	250	-	MHz
Collector-base capacitance $V_{CB} = 10\text{ V}$, $f = 1\text{ MHz}$	C_{cb}	-	6	-	pF
Delay time $V_{CC} = 30\text{ V}$, $I_C = 150\text{ mA}$, $I_{B1} = 15\text{ mA}$, $V_{BE(off)} = 0.5\text{ V}$	t_d	-	-	10	ns
Rise time $V_{CC} = 30\text{ V}$, $I_C = 150\text{ mA}$, $I_{B1} = 15\text{ mA}$, $V_{BE(off)} = 0.5\text{ V}$	t_r	-	-	40	
Storage time $V_{CC} = 30\text{ V}$, $I_C = 150\text{ mA}$, $I_{B1} = I_{B2} = 15\text{ mA}$	t_{stg}	-	-	80	
Fall time $V_{CC} = 30\text{ V}$, $I_C = 150\text{ mA}$, $I_{B1} = I_{B2} = 15\text{ mA}$	t_f	-	-	30	

Test circuits

Delay and rise time

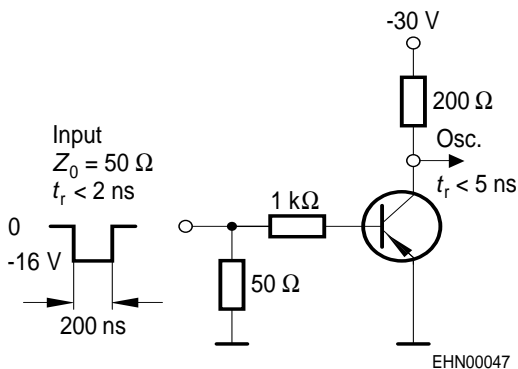

Storage and fall time

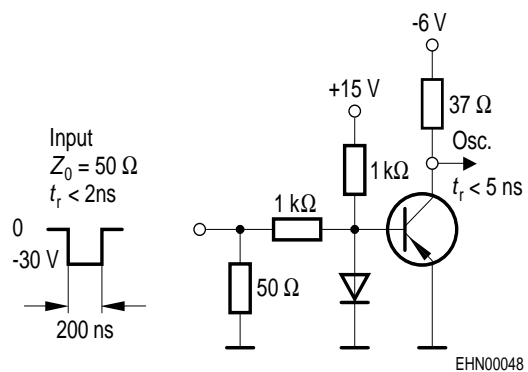

Total power dissipation $P_{tot} = f(T_S)$

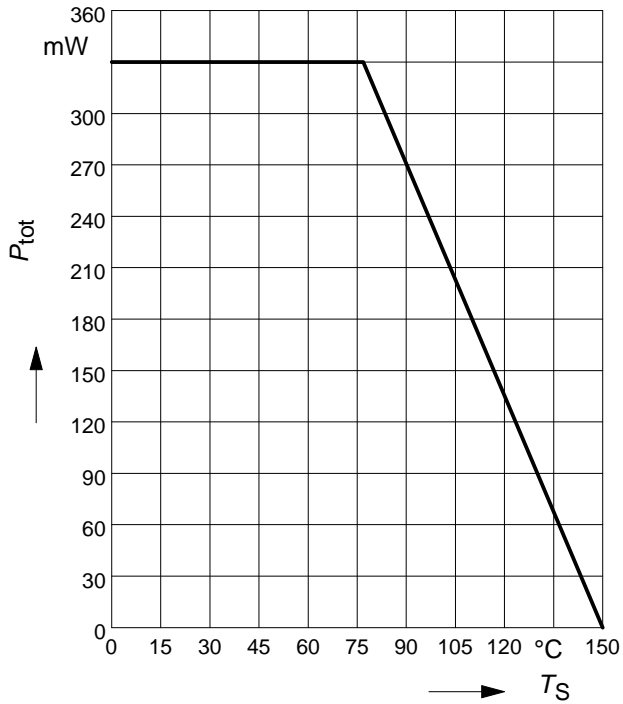

Collector-base capacitance $C_{CB} = f(V_{CB})$

$f = 1\text{MHz}$

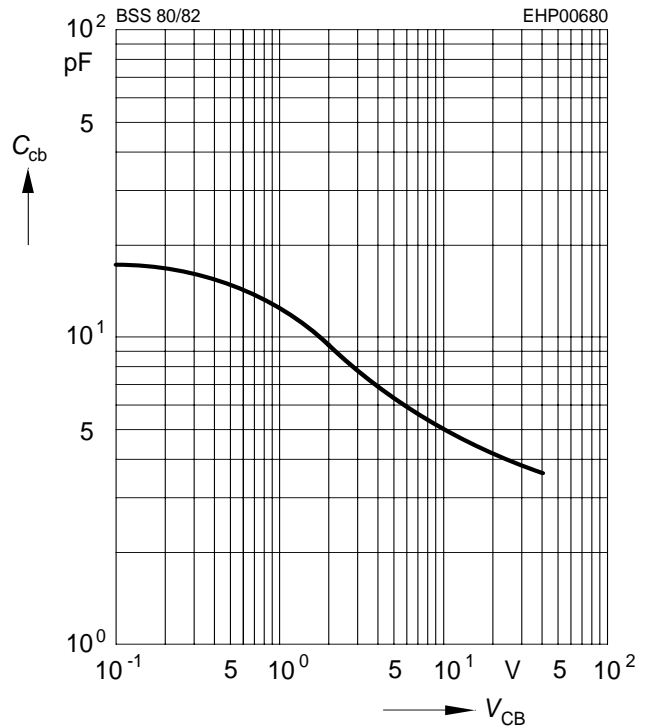

Permissible pulse load

$P_{totmax} / P_{totDC} = f(t_p)$

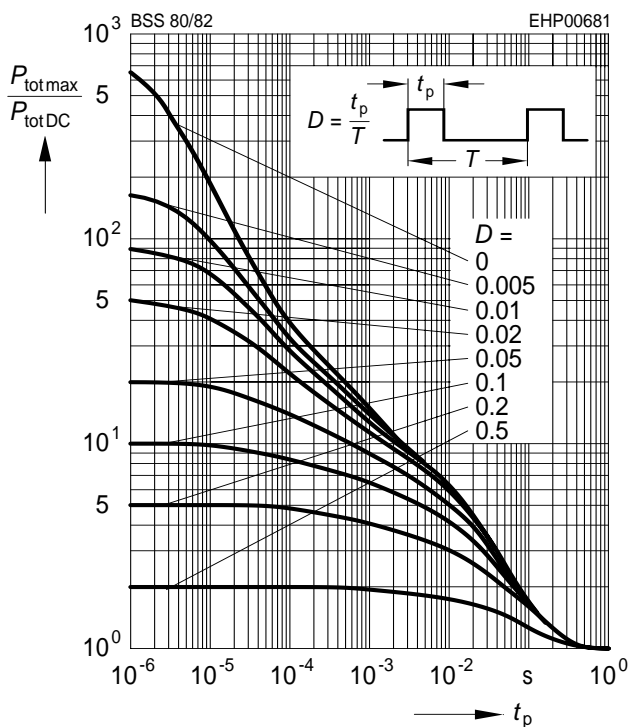

Transition frequency $f_T = f(I_C)$

$V_{CE} = 20\text{V}$

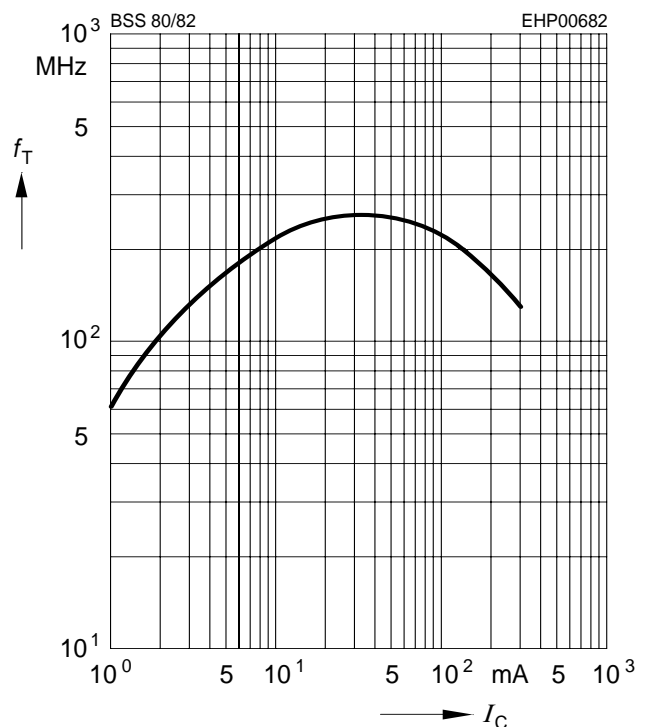

Saturation voltage $I_C = f(V_{BEsat}, V_{CEsat})$

$h_{FE} = 10$

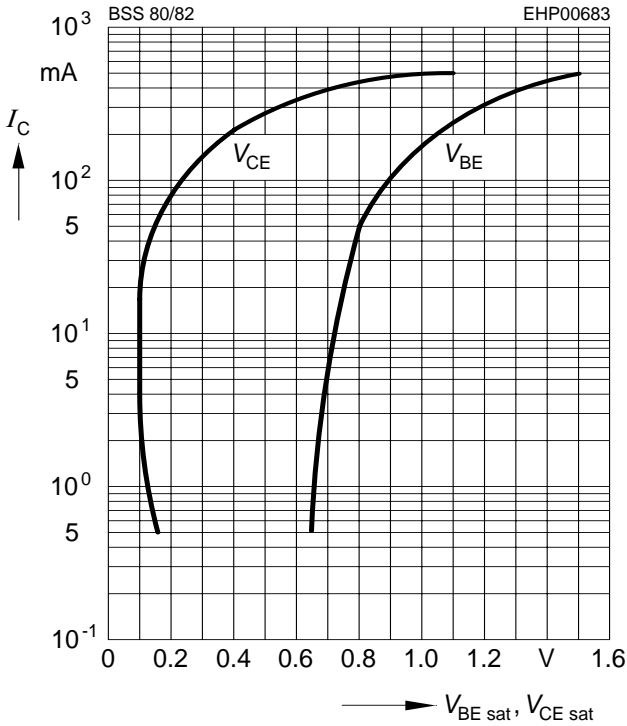

Delay time $t_d = f(I_C)$

Rise time $t_r = f(I_C)$

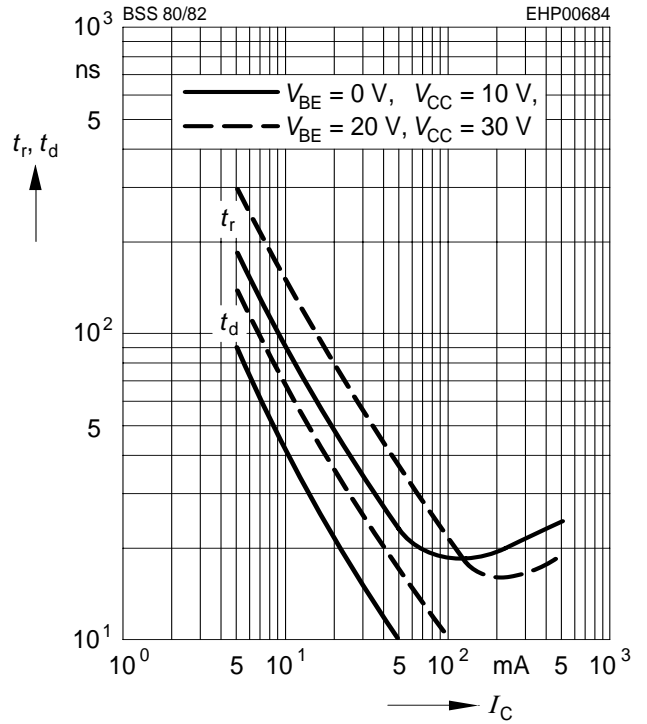

Storage time $t_{stg} = f(I_C)$

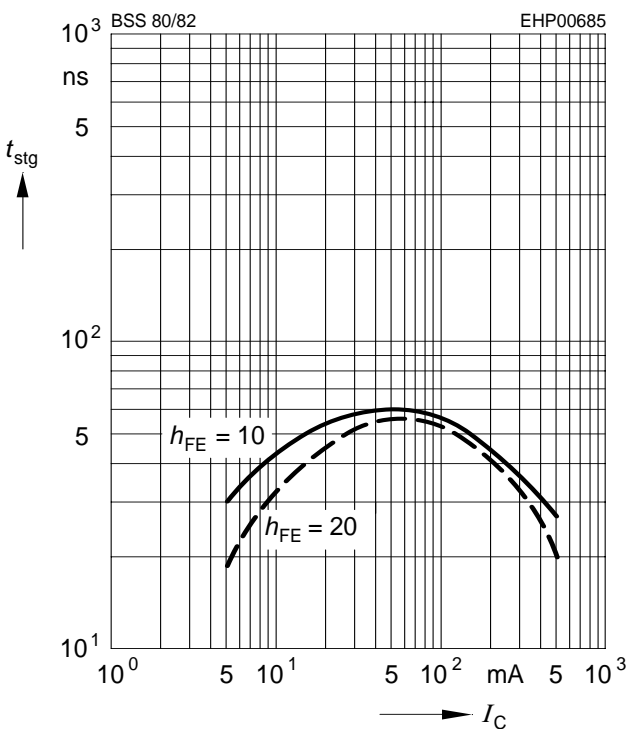

Fall time $t_f = f(I_C)$

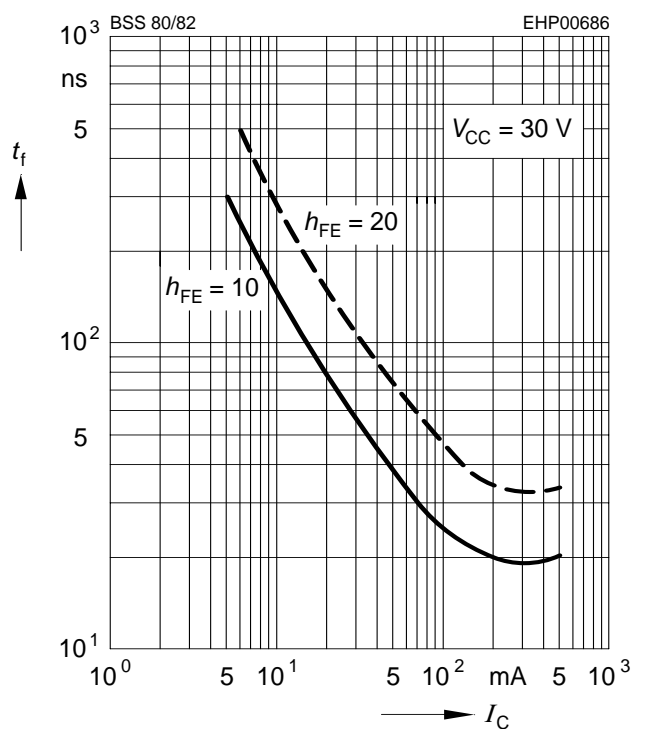

DC current gain $h_{FE} = f(I_C)$

$V_{CE} = 10V$

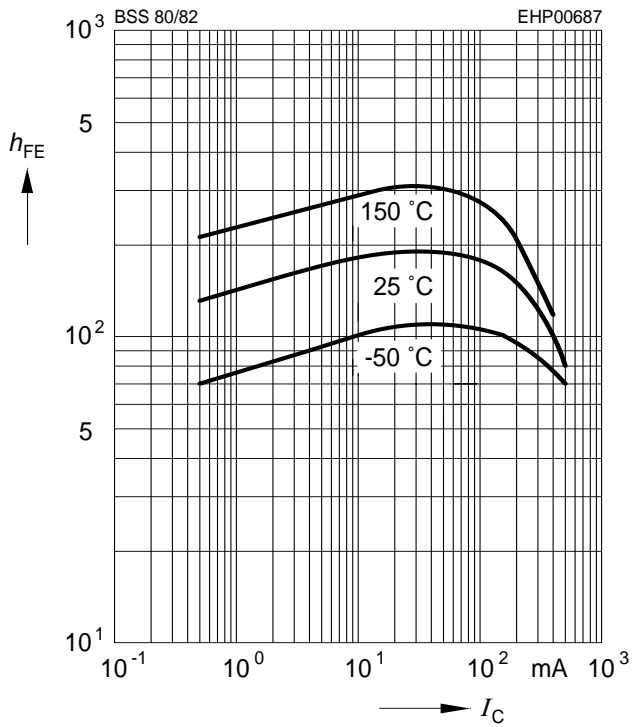

This datasheet has been downloaded from:

www.DatasheetCatalog.com

Datasheets for electronic components.



LittleDiode supplies new, hard to find or obsolete electronic components and semiconductors all over the world.

With over two million different components listed you are sure to find the part you need.

Feel free to visit us today at our online store:

LittleDiode.com

Looking forward to providing you with the best possible service.