

# DATA SHEET

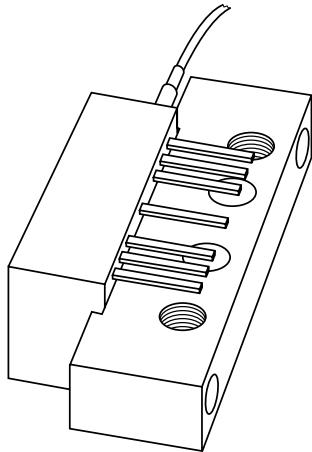

## **BGY67BO/4M** Optical receiver module

Product specification  
Supersedes data of 1998 Apr 17

2001 Sep 27

# Optical receiver module

# BGY67BO/4M

## FEATURES

- Excellent linearity
- Extremely low noise
- Excellent flatness
- Standard CATV outline
- Rugged construction
- Gold metallization ensures excellent reliability.

## APPLICATIONS

- Reverse receiver amplifier in two-way CATV systems in the 5 to 400 MHz frequency range.

## DESCRIPTION

Hybrid high dynamic range optical amplifier module in a SOT115U package operating at a voltage supply of 24 V (DC). The module contains a monomode optical input suitable for wavelengths from 1290 to 1600 nm, a terminal to monitor the pin diode current and an electrical output with an impedance of 75 Ω.

## PINNING - SOT115U

PIN	DESCRIPTION
1	monitor current
2,3,7,8	common
5	+V <sub>B</sub>
9	output

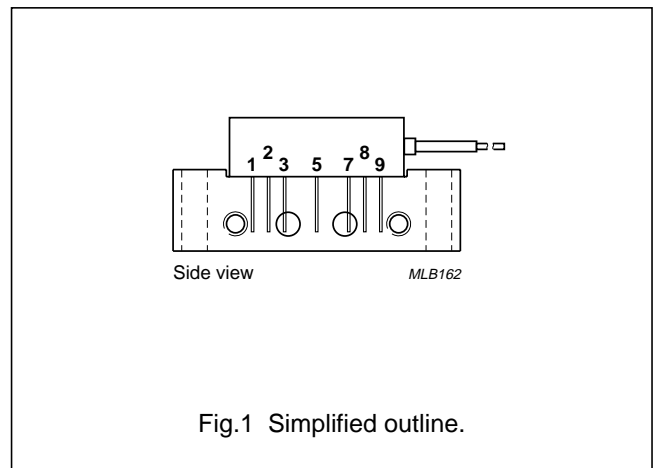

Fig.1 Simplified outline.

## QUICK REFERENCE DATA

SYMBOL	PARAMETER	CONDITIONS	MIN.	MAX.	UNIT
f	frequency range		5	400	MHz
S <sub>22</sub>	output return losses	f = 5 to 400 MHz	14	–	dB
	optical input return losses		40	–	dB
d <sub>2</sub>	second order distortion		–	–70	dBc
F	equivalent noise input	f = 5 to 400 MHz	–	7	pA/√Hz
I <sub>tot</sub>	total current consumption (DC)	V <sub>B</sub> = 24 V	150	180	mA

## HANDLING

Fibreglass optical coupling: maximum tensile strength = 5 N; minimum bending radius = 35 mm.

### CAUTION

This product is supplied in anti-static packing to prevent damage caused by electrostatic discharge during transport and handling. For further information, refer to Philips specs.: SNW-EQ-608, SNW-FQ-302A, and SNW-FQ-302B.

## Optical receiver module

## BGY67BO/4M

## LIMITING VALUES

In accordance with the Absolute Maximum Rating System (IEC 60134).

SYMBOL	PARAMETER	CONDITIONS	MIN.	MAX.	UNIT
f	frequency range		5	400	MHz
T <sub>stg</sub>	storage temperature		-40	+85	°C
T <sub>mb</sub>	operating mounting base temperature		-20	+85	°C
P <sub>in</sub>	optical input power	continuous	-	5	mW
ESD	ESD sensitivity	human body model; R = 1.5 kΩ; C = 100 pF	500	-	V

## CHARACTERISTICS

**Table 1** Bandwidth 5 to 400 MHz; V<sub>B</sub> = 24 V; T<sub>mb</sub> = 30 °C; Z<sub>L</sub> = 75 Ω

SYMBOL	PARAMETER	CONDITIONS	MIN.	MAX.	UNIT
S	responsivity	λ = 1300 nm	800	-	V/W
FL	flatness of frequency response		-	±0.3	dB
S <sub>22</sub>	output return losses	f = 5 to 400 MHz	14	-	dB
	optical input return losses		40	-	dB
d <sub>2</sub>	second order distortion	note 1	-	-70	dB
		note 2	-	-70	dB
d <sub>3</sub>	third order distortion	note 3	-	-80	dB
F	equivalent noise input	f = 5 to 400 MHz	-	7	pA/√Hz
s <sub>λ</sub>	spectral sensitivity	λ = 1310 ±20 nm	0.85	-	A/W
		λ = 1550 ±20 nm	0.9	-	A/W
λ	optical wavelength		1290	1600	nm
L	length of optical fibre	fibre; SM type; 9/125 μm	1	-	m
I <sub>tot</sub>	total current consumption (DC)	note 4	150	180	mA

## Notes

- Two laser test; each laser with 40% modulation index;  
f<sub>p</sub> = 30.25 MHz; P<sub>p</sub> = 0.5 mW;  
f<sub>q</sub> = 70 MHz; P<sub>q</sub> = 0.5 mW;  
measured at f<sub>p</sub> + f<sub>q</sub> = 100.25 MHz.
- Two laser test; each laser with 40% modulation index;  
f<sub>p</sub> = 200.25 MHz; P<sub>p</sub> = 0.5 mW;  
f<sub>q</sub> = 100 MHz; P<sub>q</sub> = 0.5 mW;  
measured at f<sub>p</sub> + f<sub>q</sub> = 300.25 MHz.
- Three laser test; each laser with 40% modulation index;  
f<sub>p</sub> = 325.25 MHz; P<sub>p</sub> = 0.33 mW;  
f<sub>q</sub> = 210.25 MHz; P<sub>q</sub> = 0.33 mW;  
f<sub>r</sub> = 135.25 MHz; P<sub>r</sub> = 0.33 mW;  
measured at f<sub>p</sub> + f<sub>q</sub> - f<sub>r</sub> = 400.25 MHz.
- The module normally operates at V<sub>B</sub> = 24 V, but is able to withstand supply transients up to 30 V.

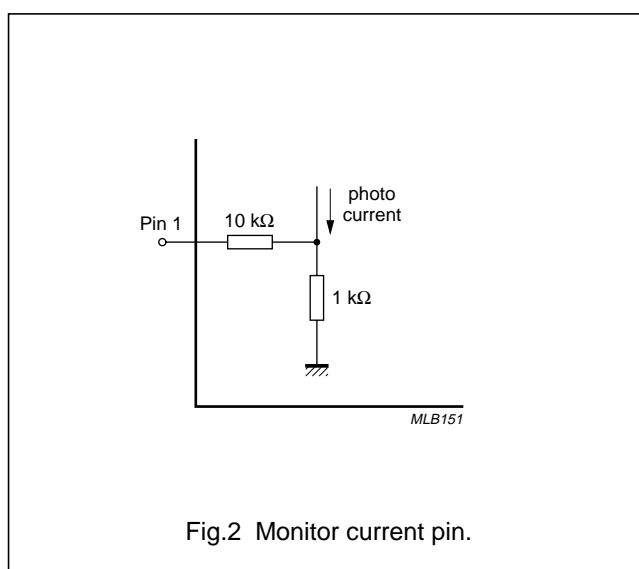

Fig.2 Monitor current pin.

# Optical receiver module

# BGY67BO/4M

## PACKAGE OUTLINE

Rectangular single-ended package; aluminium flange; 2 vertical mounting holes; 2 x 6-32 UNC and 2 extra horizontal mounting holes; optical input; 7 gold-plated in-line leads

SOT115U

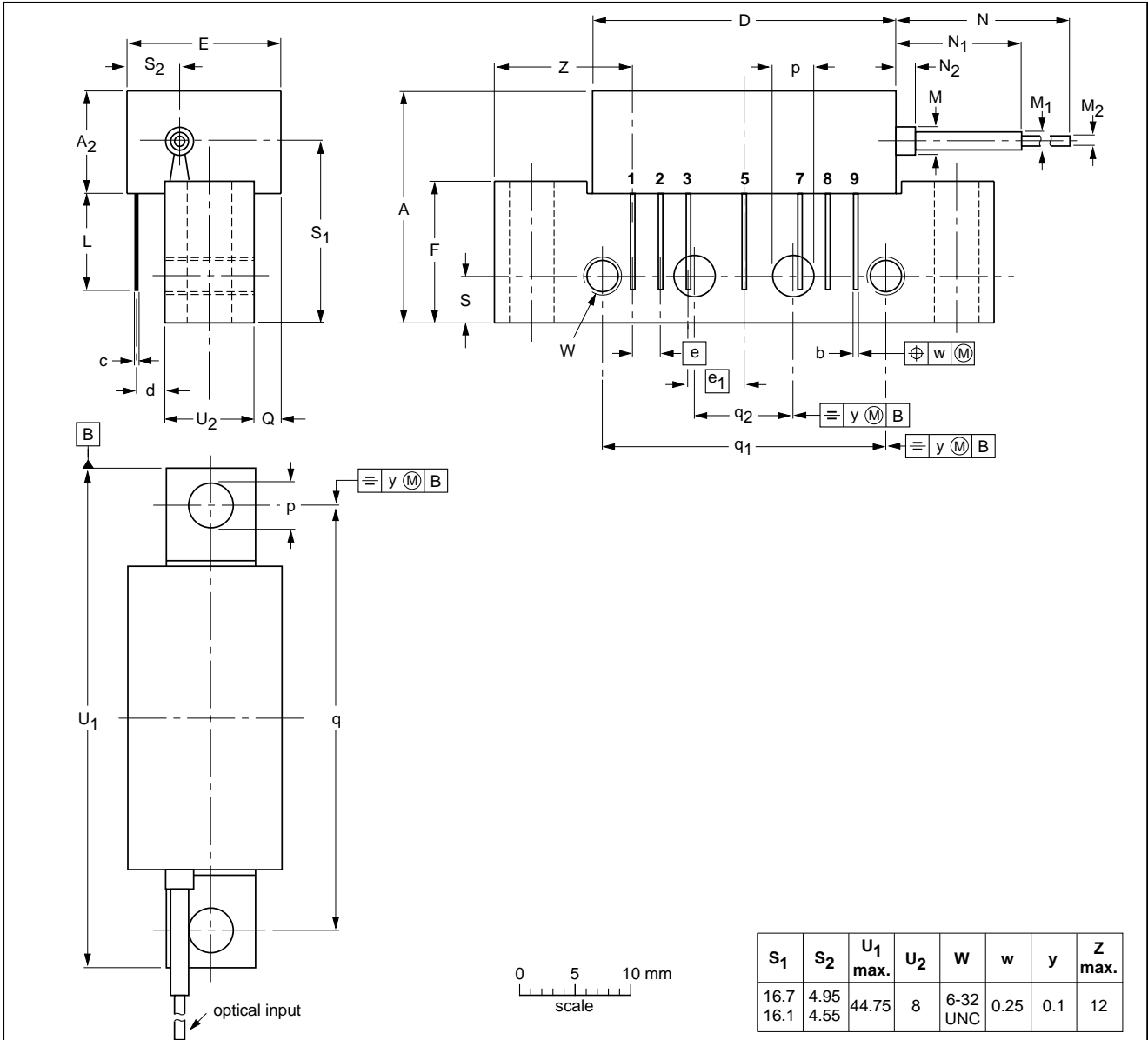

DIMENSIONS (mm are the original dimensions)

UNIT	A max.	A <sub>2</sub> max.	b	c	D max.	d max.	E max.	e	e <sub>1</sub>	F	L min.	M	M <sub>1</sub>	M <sub>2</sub>	N min.	N <sub>1</sub> max.	N <sub>2</sub> max.	p	Q max.	q	q <sub>1</sub>	q <sub>2</sub>	S
mm	20.8	9.1	0.51 0.38	0.25	27.2	2.54	13.75	2.54	5.08	12.7	8.8	2.5	1.6	0.9	1000	10.7	5	4.15 3.85	2.4	38.1	25.4	10.2	4.2

OUTLINE VERSION	REFERENCES				EUROPEAN PROJECTION	ISSUE DATE
	IEC	JEDEC	EIAJ			
SOT115U						99-04-13 01-08-10

## Optical receiver module

BGY67BO/4M

## DATA SHEET STATUS

DATA SHEET STATUS <sup>(1)</sup>	PRODUCT STATUS <sup>(2)</sup>	DEFINITIONS
Objective data	Development	This data sheet contains data from the objective specification for product development. Philips Semiconductors reserves the right to change the specification in any manner without notice.
Preliminary data	Qualification	This data sheet contains data from the preliminary specification. Supplementary data will be published at a later date. Philips Semiconductors reserves the right to change the specification without notice, in order to improve the design and supply the best possible product.
Product data	Production	This data sheet contains data from the product specification. Philips Semiconductors reserves the right to make changes at any time in order to improve the design, manufacturing and supply. Changes will be communicated according to the Customer Product/Process Change Notification (CPCN) procedure SNW-SQ-650A.

## Notes

1. Please consult the most recently issued data sheet before initiating or completing a design.
2. The product status of the device(s) described in this data sheet may have changed since this data sheet was published. The latest information is available on the Internet at URL <http://www.semiconductors.philips.com>.

## DEFINITIONS

**Short-form specification** — The data in a short-form specification is extracted from a full data sheet with the same type number and title. For detailed information see the relevant data sheet or data handbook.

**Limiting values definition** — Limiting values given are in accordance with the Absolute Maximum Rating System (IEC 60134). Stress above one or more of the limiting values may cause permanent damage to the device. These are stress ratings only and operation of the device at these or at any other conditions above those given in the Characteristics sections of the specification is not implied. Exposure to limiting values for extended periods may affect device reliability.

**Application information** — Applications that are described herein for any of these products are for illustrative purposes only. Philips Semiconductors make no representation or warranty that such applications will be suitable for the specified use without further testing or modification.

## DISCLAIMERS

**Life support applications** — These products are not designed for use in life support appliances, devices, or systems where malfunction of these products can reasonably be expected to result in personal injury. Philips Semiconductors customers using or selling these products for use in such applications do so at their own risk and agree to fully indemnify Philips Semiconductors for any damages resulting from such application.

**Right to make changes** — Philips Semiconductors reserves the right to make changes, without notice, in the products, including circuits, standard cells, and/or software, described or contained herein in order to improve design and/or performance. Philips Semiconductors assumes no responsibility or liability for the use of any of these products, conveys no licence or title under any patent, copyright, or mask work right to these products, and makes no representations or warranties that these products are free from patent, copyright, or mask work right infringement, unless otherwise specified.

Optical receiver module

BGY67BO/4M

---

**NOTES**

Optical receiver module

BGY67BO/4M

---

**NOTES**

# ***Philips Semiconductors – a worldwide company***

## **Contact information**

For additional information please visit <http://www.semiconductors.philips.com>. Fax: +31 40 27 24825

For sales offices addresses send e-mail to: [sales.addresses@www.semiconductors.philips.com](mailto:sales.addresses@www.semiconductors.philips.com).

© Koninklijke Philips Electronics N.V. 2001

SCA73

All rights are reserved. Reproduction in whole or in part is prohibited without the prior written consent of the copyright owner.

The information presented in this document does not form part of any quotation or contract, is believed to be accurate and reliable and may be changed without notice. No liability will be accepted by the publisher for any consequence of its use. Publication thereof does not convey nor imply any license under patent- or other industrial or intellectual property rights.

Printed in The Netherlands

613518/04/pp8

Date of release: 2001 Sep 27

Document order number: 9397 750 08697

*Let's make things better.*

**Philips  
Semiconductors**



**PHILIPS**



LittleDiode supplies new, hard to find or obsolete electronic components and semiconductors all over the world.

With over two million different components listed you are sure to find the part you need.

Feel free to visit us today at our online store:

[LittleDiode.com](http://LittleDiode.com)

Looking forward to providing you with the best possible service.