

## HiRel NPN Silicon RF Transistor

- **HiRel Discrete and Microwave Semiconductor**
- For Medium Power Amplifiers
- Compression Point  $P_{-1dB} = 19dBm$  1.8 GHz  
Max. Available Gain  $G_{ma} = 16dB$  at 1.8 GHz
- Hermetically sealed microwave package
- Transition Frequency  $f_T = 20$  GHz
- **SIEGET 25-Line**  
Infineon Technologies Grounded Emitter Transistor-  
25 GHz  $f_T$ -Line
-  **esa Space Qualified**  
ESA/SCC Detail Spec. No.: 5611/008  
Type Variant No. 03

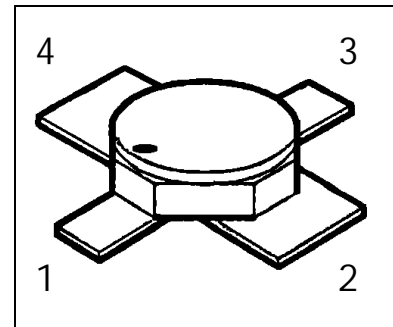

**ESD:** Electrostatic discharge sensitive device,  
observe handling precautions!

Type	Marking	Ordering Code	Pin Configuration				Package
			1	2	3	4	
BFY450 (q)	-	see below	C	E	B	E	Micro-X

(q) Quality Level:	P: Professional Quality,	Ordering Code:	Q62702F1663
	H: High Rel Quality,	Ordering Code:	on request
	S: Space Quality,	Ordering Code:	on request
	ES: ESA Space Quality,	Ordering Code:	Q62702F1708

(see order instructions for ordering example)

**Maximum Ratings**

Parameter	Symbol	Values	Unit
Collector-emitter voltage	$V_{CEO}$	4.5	V
Collector-base voltage	$V_{CBO}$	15	V
Emitter-base voltage	$V_{EBO}$	1.5	V
Collector current	$I_C$	100	mA
Base current	$I_B$	10	mA
Total power dissipation, $T_S \leq 110^\circ\text{C}$ <sup>1), 2)</sup>	$P_{tot}$	450	mW
Junction temperature	$T_j$	175	$^\circ\text{C}$
Operating temperature range	$T_{op}$	-65...+175	$^\circ\text{C}$
Storage temperature range	$T_{stg}$	-65...+175	$^\circ\text{C}$

**Thermal Resistance**

Junction-soldering point <sup>2)</sup>	$R_{thJS}$	< 145	K/W
--	------------	-------	-----

**Notes.:**

- 1) At  $T_S = +110^\circ\text{C}$ . For  $T_S > +110^\circ\text{C}$  derating is required.
- 2)  $T_S$  is measured on the collector lead at the soldering point to the pcb.

**Electrical Characteristics**

 at  $T_A = 25^\circ\text{C}$ ; unless otherwise specified

Parameter	Symbol	Values			Unit
		min.	typ.	max.	

**DC Characteristics**

Collector-base cutoff current $V_{CB} = 5\text{ V}, I_E = 0$	$I_{CBO}$	-	-	100	nA
Collector-emitter cutoff current <sup>1.)</sup> $V_{CE} = 4.5\text{ V}, I_B = 1.0\mu\text{A}$	$I_{CEX}$	-	-	200 (t.b.d.)	$\mu\text{A}$
Emitter-base cutoff current $V_{EB} = 1.5\text{ V}, I_C = 0$	$I_{EBO}$	-	-	50	$\mu\text{A}$
DC current gain $I_C = 20\text{ mA}, V_{CE} = 1\text{ V}$	$h_{FE}$	50	90	150	-

**Notes:**

- 1.) This Test assures  $V(BR)_{CE0} > 4.5\text{V}$

**Electrical Characteristics (continued)**

Parameter	Symbol	Values			Unit
		min.	typ.	max.	
<b>AC Characteristics</b>					
Transition frequency $I_C = 90\text{mA}$ , $V_{CE} = 3\text{ V}$ , $f = 1.0\text{ GHz}$ $I_C = 90\text{mA}$ , $V_{CE} = 3\text{ V}$ , $f = 2.0\text{ GHz}$	$f_T$	18 -	22 17	- -	GHz
Collector-base capacitance $V_{CB} = 2\text{ V}$ , $V_{BE} = v_{be} = 0$ , $f = 1\text{ MHz}$	$C_{CB}$	-	0.42	0.9	pF
Collector-emitter capacitance $V_{CE} = 2\text{ V}$ , $V_{BE} = v_{be} = 0$ , $f = 1\text{ MHz}$	$C_{CE}$	-	1.27	2.6	pF
Emitter-base capacitance $V_{EB} = 0.5\text{V}$ , $V_{CB} = v_{cb} = 0$ , $f = 1\text{ MHz}$	$C_{EB}$	-	2.0	3	pF
Noise Figure $I_C = 10\text{ mA}$ , $V_{CE} = 2\text{ V}$ , $f = 1.8\text{ GHz}$ , $Z_S = Z_{\text{sopt}}$	F	-	1.25	2.0	dB
Insertion power gain $I_C = 50\text{ mA}$ , $V_{CE} = 2\text{ V}$ , $f = 1.8\text{ GHz}$ $Z_S = Z_L = 50\ \Omega$	$ S_{21e} ^2$	8.0	12	-	dB
Power gain $I_C = 50\text{ mA}$ , $V_{CE} = 2\text{ V}$ , $f = 1.8\text{ GHz}$ $Z_S = Z_{\text{sopt}}$ , $Z_L = Z_{\text{lopt}}$	$G_{ma}$ <sup>1)</sup>	-	16.0	-	dB
1dB Compression point $I_C = 50\text{ mA}$ , $V_{CE} = 2\text{ V}$ , $f = 1.8\text{ GHz}$ $Z_S = Z_{\text{sopt}}$ , $Z_L = Z_{\text{lopt}}$	$P_{-1\text{dB}}$	-	19	-	dBm

**Notes.:**

$$1) \quad G_{ma} = \left| \frac{S_{21}}{S_{12}} \right| (k - \sqrt{k^2 - 1}), \quad G_{ms} = \left| \frac{S_{21}}{S_{12}} \right|$$

**Order Instructions:**

Full type variant including quality level must be specified by the orderer. For *HiRel* Discrete and Microwave Semiconductors the ordering code specifies device family and quality level.

**Ordering Form:**

Ordering Code: Q.....  
BFY450 (ql)  
(ql): Quality Level

**Ordering Example:**

Ordering Code: Q62702F1708  
BFY450 ES  
For BFY450 in ESA Space Quality Level

**Further Informations:**

See our WWW-Pages:

- Discrete and RF-Semiconductors (Small Signal Semiconductors)

[www.infineon.com/products/discrete/hirel.htm](http://www.infineon.com/products/discrete/hirel.htm)

- *HiRel* Discrete and Microwave Semiconductors

[www.infineon.com/products/discrete/hirel.htm](http://www.infineon.com/products/discrete/hirel.htm)

Please contact also our marketing division :

Tel.: ++89 234 24480  
Fax.: ++89 234 28438  
e-mail: martin.wimmers@infineon.com  
Address: Infineon Technologies Semiconductors,  
High Frequency Products Marketing,  
P.O.Box 801709,  
D-81617 Munich

## Micro-X Package

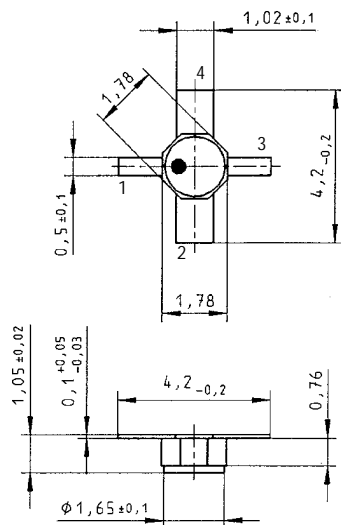

Published by Infineon Technologies Semiconductors, High Frequency Products Marketing, P.O.Box 801709, D-81617 Munich.

Infineon Technologies AG 1998. All Rights Reserved.

As far as patents or other rights of third parties are concerned, liability is only assumed for components per se, not for applications, processes and circuits implemented within components or assemblies.

The information describes the type of component and shall not be considered as assured characteristics.

Terms of delivery and rights to change design reserved.

For questions on technology, delivery and prices please contact the Offices of Semiconductor Group in Germany or the Infineon Technologies Companies and Representatives worldwide (see address list).

Due to technical requirements components may contain dangerous substances. For information on the type in question please contact your nearest Infineon Technologies Office, Semiconductor Group.

Infineon Technologies Semiconductors is a certified CECC and QS9000 manufacturer (this includes ISO 9000).

This datasheet has been downloaded from:

[www.DatasheetCatalog.com](http://www.DatasheetCatalog.com)

Datasheets for electronic components.



LittleDiode supplies new, hard to find or obsolete electronic components and semiconductors all over the world.

With over two million different components listed you are sure to find the part you need.

Feel free to visit us today at our online store:

[LittleDiode.com](http://LittleDiode.com)

Looking forward to providing you with the best possible service.