

HiRel NPN Silicon RF Transistor

- **HiRel Discrete and Microwave Semiconductor**
- For low noise, high-gain broadband amplifiers at collector currents from 1 mA to 20 mA.
- Hermetically sealed microwave package
- $f_T = 8$ GHz
F = 2.4 dB at 2 GHz
-  **ESA Space Qualified**
ESA/SCC Detail Spec. No.: 5611/006
Type Variant No. 04

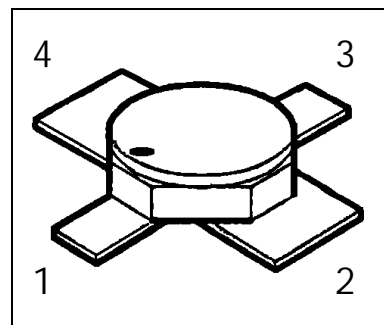

ESD: Electrostatic discharge sensitive device, observe handling precautions!

Type	Marking	Ordering Code	Pin Configuration				Package
			C	E	B	E	
BFY182 (ql)	-	see below	C	E	B	E	Micro-X1

(ql) Quality Level:	P: Professional Quality,	Ordering Code:	Q62702F1608
	H: High Rel Quality,	Ordering Code:	on request
	S: Space Quality,	Ordering Code:	on request
	ES: ESA Space Quality,	Ordering Code:	Q62702F1714

(see order instructions for ordering example)

Maximum Ratings

Parameter	Symbol	Values	Unit
Collector-emitter voltage	V_{CEO}	12	V
Collector-emitter voltage, $V_{BE}=0$	V_{CES}	20	V
Collector-base voltage	V_{CBO}	20	V
Emitter-base voltage	V_{EBO}	2	V
Collector current	I_C	35	mA
Base current	I_B	4 ¹⁾	mA
Total power dissipation, $T_S \leq 136^\circ\text{C}$ ^{2),3)}	P_{tot}	250	mW
Junction temperature	T_J	200	$^\circ\text{C}$
Operating temperature range	T_{op}	-65...+200	$^\circ\text{C}$
Storage temperature range	T_{stg}	-65...+200	$^\circ\text{C}$

Thermal Resistance

Junction-soldering point ³⁾	R_{thJS}	< 255	K/W
----------------------------------------	------------	-------	-----

Notes.:

- 1) The maximum permissible base current for V_{FBE} measurements is 20mA (spot-measurement duration < 1s)
- 2) At $T_S = +136^\circ\text{C}$. For $T_S > +136^\circ\text{C}$ derating is required.
- 3) T_S is measured on the collector lead at the soldering point to the pcb.

Electrical Characteristics

 at $T_A=25^\circ\text{C}$; unless otherwise specified

Parameter	Symbol	Values			Unit
		min.	typ.	max.	

DC Characteristics

Collector-base cutoff current $V_{CB} = 20\text{ V}, I_E = 0$	I_{CBO}	-	-	100	μA
Collector-emitter cutoff current $V_{CE} = 12\text{ V}, I_B = 0.2\mu\text{A}$ ^{1.)}	I_{CEX}	-	-	200	μA
Collector-base cutoff current $V_{CB} = 10\text{ V}, I_E = 0$	I_{CBO}	-	-	50	nA
Emitter base cutoff current $V_{EB} = 2\text{ V}, I_C = 0$	I_{EBO}	-	-	25	μA
Emitter base cutoff current $V_{EB} = 1\text{ V}, I_C = 0$	I_{EBO}	-	-	0.5	μA

Notes:

- 1.) This Test assures $V(BR)_{CE0} > 12\text{V}$

Electrical Characteristics (continued)

Parameter	Symbol	Values			Unit
		min.	typ.	max.	
DC Characteristics					
Base-Emitter forward voltage $I_E = 20 \text{ mA}, I_C = 0$	V_{FBE}	-	-	1	V
DC current gain $I_C = 5 \text{ mA}, V_{CE} = 6 \text{ V}$	h_{FE}	55	100	170	-
AC Characteristics					
Transition frequency $I_C = 15 \text{ mA}, V_{CE} = 5 \text{ V}, f = 500 \text{ MHz}$ $I_C = 15 \text{ mA}, V_{CE} = 8 \text{ V}, f = 500 \text{ MHz}$	f_T	6.5 -	7.5 8	- -	GHz
Collector-base capacitance $V_{CB} = 10 \text{ V}, V_{BE} = v_{be} = 0, f = 1 \text{ MHz}$	C_{CB}	-	0.26	0.36	pF
Collector-emitter capacitance $V_{CE} = 10 \text{ V}, V_{BE} = v_{be} = 0, f = 1 \text{ MHz}$	C_{CE}	-	0.34	-	pF
Emitter-base capacitance $V_{EB} = 0.5 \text{ V}, V_{CB} = v_{cb} = 0, f = 1 \text{ MHz}$	C_{EB}	-	0.8	1.1	pF
Noise Figure $I_C = 5 \text{ mA}, V_{CE} = 5 \text{ V}, f = 2 \text{ GHz},$ $Z_S = Z_{Sopt}$	F	-	2.4	2.9	dB
Power gain $I_C = 15 \text{ mA}, V_{CE} = 5 \text{ V}, f = 2 \text{ GHz}$ $Z_S = Z_{Sopt}, Z_L = Z_{Lopt}$	$G_{ma}^{1)}$	13.5	14.5	-	dB
Transducer gain $I_C = 15 \text{ mA}, V_{CE} = 5 \text{ V}, f = 2 \text{ GHz}$ $Z_S = Z_L = 50 \Omega$	$ S_{21e} ^2$	10	11	-	dB

Notes.:

$$1) \quad G_{ma} = \left| \frac{S_{21}}{S_{12}} \right| (k - \sqrt{k^2 - 1}), \quad G_{ms} = \left| \frac{S_{21}}{S_{12}} \right|$$

Order Instructions:

Full type variant including quality level must be specified by the orderer. For *HiRel* Discrete and Microwave Semiconductors the ordering code specifies device family and quality level.

Ordering Form:

Ordering Code: Q.....
BFY182 (ql)
(ql): Quality Level

Ordering Example:

Ordering Code: Q62702F1714
BFY182 ES
For BFY182 in ESA Space Quality Level

Further Informations:

See our WWW-Pages:

- Discrete and RF-Semiconductors (Small Signal Semiconductors)

www.infineon.com/products/discrete/hirel.htm

- *HiRel* Discrete and Microwave Semiconductors

www.infineon.com/products/discrete/hirel.htm

Please contact also our marketing division :

Tel.: ++89 234 24480

Fax.: ++89 234 28438

e-mail: martin.wimmers@infineon.com

Address: Infineon -Technologies Semiconductors,
High Frequency Products Marketing,
P.O.Box 801709,
D-81617 Munich

Micro-X1 Package

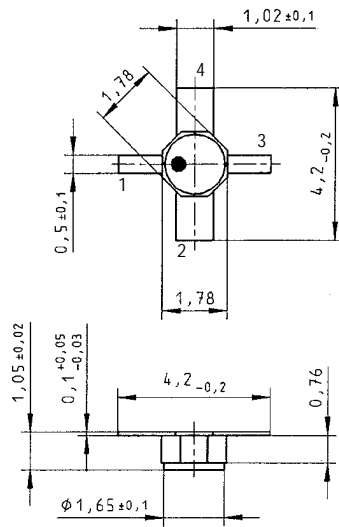

Published by Infineon Technologies Semiconductors, High Frequency Products Marketing, P.O.Box 801709, D-81617 Munich.

Infineon Technologies AG 1998. All Rights Reserved.

As far as patents or other rights of third parties are concerned, liability is only assumed for components per se, not for applications, processes and circuits implemented within components or assemblies.

The information describes the type of component and shall not be considered as assured characteristics.

Terms of delivery and rights to change design reserved.

For questions on technology, delivery and prices please contact the Offices of Semiconductor Group in Germany or the Infineon Technologies Companies and Representatives worldwide (see address list).

Due to technical requirements components may contain dangerous substances. For information on the type in question please contact your nearest Infineon Technologies Office, Semiconductor Group.

Infineon Technologies Semiconductors is a certified CECC and QS9000 manufacturer (this includes ISO 9000).

This datasheet has been downloaded from:

www.DatasheetCatalog.com

Datasheets for electronic components.



LittleDiode supplies new, hard to find or obsolete electronic components and semiconductors all over the world.

With over two million different components listed you are sure to find the part you need.

Feel free to visit us today at our online store:

LittleDiode.com

Looking forward to providing you with the best possible service.