



## Silicon NPN Planar RF Transistor

Electrostatic sensitive device.  
Observe precautions for handling.



### Applications

Wide band, low noise, small signal amplifiers up to UHF frequencies, high speed logic applications and oscillator applications.

### Features

- Low noise figure
- High power gain
- Small collector capacitance

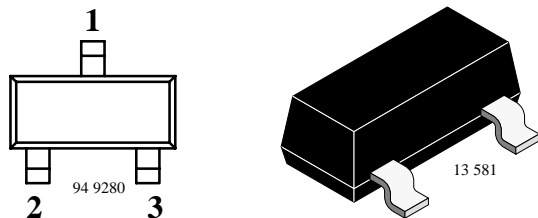

BFS17A Marking: E2  
Plastic case (SOT 23)  
1 = Collector, 2 = Base, 3 = Emitter

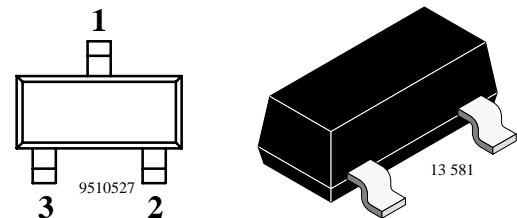

BFS17AR Marking: E5  
Plastic case (SOT 23)  
1 = Collector, 2 = Base, 3 = Emitter

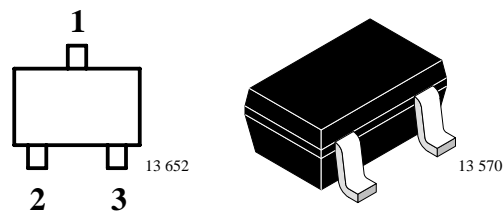

BFS17AW Marking: WE2  
Plastic case (SOT 323)  
1 = Collector, 2 = Base, 3 = Emitter

### Absolute Maximum Ratings

$T_{amb} = 25^{\circ}\text{C}$ , unless otherwise specified

Parameter	Test Conditions	Symbol	Value	Unit
Collector-base voltage		$V_{CBO}$	25	V
Collector-emitter voltage		$V_{CEO}$	15	V
Emitter-base voltage		$V_{EBO}$	2.5	V
Collector current		$I_C$	25	mA
Total power dissipation	$T_{amb} \leq 60^{\circ}\text{C}$	$P_{tot}$	200	mW
Junction temperature		$T_j$	150	$^{\circ}\text{C}$
Storage temperature range		$T_{stg}$	-65 to +150	$^{\circ}\text{C}$

### Maximum Thermal Resistance

$T_{amb} = 25^{\circ}\text{C}$ , unless otherwise specified

Parameter	Test Conditions	Symbol	Value	Unit
Junction ambient	on glass fibre printed board (25 x 20 x 1.5) mm <sup>3</sup> plated with 35µm Cu	$R_{thJA}$	450	K/W

### Electrical DC Characteristics

$T_{amb} = 25^{\circ}\text{C}$ , unless otherwise specified

Parameter	Test Conditions	Symbol	Min	Typ	Max	Unit
Collector cut-off current	$V_{CE} = 25\text{ V}$ , $V_{BE} = 0$	$I_{CES}$			100	µA
Collector-base cut-off current	$V_{CB} = 10\text{ V}$ , $I_E = 0$	$I_{CBO}$			100	nA
Emitter-base cut-off current	$V_{EB} = 2.5\text{ V}$ , $I_C = 0$	$I_{EBO}$			10	µA
Collector-emitter breakdown voltage	$I_C = 1\text{ mA}$ , $I_B = 0$	$V_{(BR)CEO}$	15			V
Collector-emitter saturation voltage	$I_C = 20\text{ mA}$ , $I_B = 2\text{ mA}$	$V_{CEsat}$		0.1	0.6	V
DC forward current transfer ratio	$V_{CE} = 1\text{ V}$ , $I_C = 2\text{ mA}$	$h_{FE}$	20	50	150	
	$V_{CE} = 1\text{ V}$ , $I_C = 25\text{ mA}$	$h_{FE}$	20			

### Electrical AC Characteristics

$T_{amb} = 25^{\circ}\text{C}$ , unless otherwise specified

Parameter	Test Conditions	Symbol	Min	Typ	Max	Unit
Transition frequency	$V_{CE} = 5\text{ V}$ , $I_C = 2\text{ mA}$ , $f = 300\text{ MHz}$	$f_T$		1.5		GHz
	$V_{CE} = 5\text{ V}$ , $I_C = 14\text{ mA}$ , $f = 300\text{ MHz}$	$f_T$		3.5		GHz
	$V_{CE} = 5\text{ V}$ , $I_C = 30\text{ mA}$ , $f = 300\text{ MHz}$	$f_T$	3	3.2		GHz
Collector-base capacitance	$V_{CB} = 10\text{ V}$ , $f = 1\text{ MHz}$	$C_{cb}$		0.6		pF
Collector-emitter capacitance	$V_{CE} = 5\text{ V}$ , $f = 1\text{ MHz}$	$C_{ce}$		0.1		pF
Emitter-base capacitance	$V_{EB} = 0.5\text{ V}$ , $f = 1\text{ MHz}$	$C_{eb}$		1.1		pF
Noise figure	$V_{CE} = 5\text{ V}$ , $I_C = 2\text{ mA}$ , $Z_S = 50\ \Omega$ , $f = 800\text{ MHz}$	F		2.5		dB
Power gain	$V_{CE} = 10\text{ V}$ , $I_C = 14\text{ mA}$ , $Z_S = 50\ \Omega$ , $f = 800\text{ MHz}$	$G_{pe}$		13		dB
Linear output voltage – two tone intermodulation test	$V_{CE} = 10\text{ V}$ , $I_C = 14\text{ mA}$ , $d_{IM} = 60\text{ dB}$ , $f_1 = 806\text{ MHz}$ , $f_2 = 810\text{ MHz}$ , $Z_S = Z_L = 50\ \Omega$	$V_1 = V_2$		150		mV
Third order intercept point	$V_{CE} = 10\text{ V}$ , $I_C = 14\text{ mA}$ , $f = 800\text{ MHz}$	$IP_3$		23.5		dBm



## Common Emitter S-Parameters

$Z_0 = 50 \Omega$ ,  $T_{amb} = 25^\circ\text{C}$ , unless otherwise specified

$V_{CE}/V$	$I_C/mA$	f/MHz	S11		S21		S12		S22	
			LIN MAG	ANG	LIN MAG	ANG	LIN MAG	ANG	LIN MAG	ANG
				deg		deg		deg		deg
5	2	100	0.829	-29.5	6.22	158.9	0.028	74.2	0.965	-8.9
		300	0.672	-79.5	4.80	126.1	0.064	53.3	0.812	-19.2
		500	0.544	-113.6	3.54	105.6	0.078	45.2	0.707	-21.7
		800	0.457	-145.4	2.43	88.0	0.087	45.7	0.648	-22.5
		1000	0.442	-160.1	2.03	79.5	0.093	49.6	0.639	-23.9
		1200	0.444	-172.5	1.77	72.2	0.101	54.0	0.634	-26.6
		1500	0.463	172.1	1.49	61.7	0.117	60.6	0.619	-31.5
		1800	0.474	159.0	1.31	52.3	0.142	65.5	0.596	-36.2
	2000	0.493	153.0	1.22	45.0	0.168	65.6	0.559	-39.7	
	5	100	0.658	-45.1	12.07	149.5	0.025	69.6	0.909	-14.4
		300	0.485	-106.3	7.43	113.4	0.048	55.1	0.668	-23.0
		500	0.409	-139.6	4.93	96.8	0.061	55.7	0.572	-21.6
		800	0.370	-166.3	3.23	82.7	0.080	61.4	0.537	-19.7
		1000	0.369	-177.7	2.65	75.8	0.094	64.1	0.540	-20.6
		1200	0.373	173.9	2.28	69.3	0.110	66.3	0.540	-23.3
		1500	0.397	162.7	1.89	60.3	0.136	68.2	0.529	-28.0
		1800	0.417	152.7	1.64	51.7	0.166	68.2	0.510	-31.5
	2000	0.440	148.7	1.52	44.4	0.193	65.2	0.479	-33.4	
	10	100	0.480	-65.1	17.64	139.7	0.020	67.8	0.833	-19.2
		300	0.376	-130.2	8.89	105.3	0.039	62.6	0.570	-22.9
		500	0.355	-158.2	5.66	91.6	0.055	66.2	0.499	-19.4
		800	0.336	-179.7	3.63	79.6	0.081	69.7	0.484	-16.6
		1000	0.336	171.9	2.95	73.5	0.098	70.8	0.492	-17.6
		1200	0.343	165.2	2.53	67.7	0.117	71.2	0.497	-20.5
1500		0.370	157.2	2.09	59.3	0.145	70.8	0.486	-25.1	
1800		0.393	149.1	1.80	50.9	0.177	69.0	0.470	-28.2	
2000	0.420	147.0	1.66	44.0	0.204	65.1	0.445	-29.1		

# BFS17A/BFS17AR/BFS17AW



Vishay Semiconductors

V <sub>CE</sub> /V	I <sub>C</sub> /mA	f/MHz	S11		S21		S12		S22	
			LIN MAG	ANG	LIN MAG	ANG	LIN MAG	ANG	LIN MAG	ANG
				deg		deg		deg		deg
5	15	100	0.390	-81.5	20.46	133.8	0.018	67.5	0.780	-21.3
		300	0.344	-143.8	9.34	101.4	0.036	66.9	0.532	-21.6
		500	0.340	-167.0	5.87	89.3	0.054	70.8	0.476	-17.3
		800	0.332	174.4	3.74	78.1	0.081	73.0	0.470	-14.7
		1000	0.333	167.1	3.04	72.2	0.100	73.1	0.481	-15.9
		1200	0.336	161.9	2.60	66.7	0.119	72.8	0.485	-19.2
		1500	0.367	155.3	2.14	58.5	0.149	71.8	0.476	-23.7
		1800	0.391	147.4	1.84	50.6	0.181	69.5	0.461	-26.8
	2000	0.416	145.8	1.70	43.6	0.207	65.3	0.437	-27.5	
	20	100	0.342	-95.6	21.91	129.4	0.016	68.3	0.743	-21.9
		300	0.337	-152.5	9.44	99.0	0.035	70.3	0.515	-19.9
		500	0.340	-172.8	5.85	87.8	0.053	73.6	0.469	-16.0
		800	0.333	170.8	3.74	77.0	0.081	75.0	0.469	-13.6
		1000	0.334	164.8	3.03	71.4	0.100	74.4	0.482	-15.1
		1200	0.342	159.2	2.59	65.9	0.120	73.9	0.485	-18.4
		1500	0.371	153.9	2.14	57.8	0.149	72.7	0.476	-23.1
1800		0.398	147.0	1.84	49.7	0.181	70.2	0.461	-26.2	
2000	0.423	144.8	1.69	42.8	0.207	65.8	0.438	-27.0		
10	2	100	0.827	-29.0	6.37	157.9	0.024	73.1	0.965	-7.7
		300	0.651	-76.2	4.81	126.6	0.053	53.9	0.835	-15.4
		500	0.534	-108.9	3.58	107.7	0.065	47.2	0.759	-17.6
		800	0.457	-140.7	2.51	90.1	0.073	48.8	0.712	-19.4
		1000	0.437	-157.5	2.09	81.4	0.079	52.7	0.701	-21.1
		1200	0.438	-170.6	1.81	73.8	0.086	57.8	0.695	-23.4
		1500	0.441	173.7	1.51	64.2	0.099	65.6	0.688	-27.4
		1800	0.454	160.4	1.31	56.1	0.119	71.8	0.685	-32.3
	2000	0.470	152.5	1.22	50.8	0.136	74.9	0.681	-35.5	
	5	100	0.658	-43.5	12.32	148.9	0.021	69.7	0.913	-12.5
		300	0.462	-102.5	7.51	114.5	0.041	55.8	0.711	-18.3
		500	0.390	-133.9	5.05	98.6	0.052	57.2	0.645	-17.4
		800	0.355	-161.4	3.35	84.2	0.068	63.2	0.618	-17.8
		1000	0.353	-174.5	2.74	77.2	0.081	66.6	0.613	-19.3
		1200	0.357	175.4	2.34	70.8	0.094	69.3	0.613	-21.5
		1500	0.372	163.3	1.94	62.6	0.115	72.2	0.610	-25.5
1800		0.390	153.6	1.67	55.0	0.139	74.0	0.607	-30.1	
2000	0.406	146.9	1.54	50.3	0.157	74.5	0.604	-33.4		



# BFS17A/BFS17AR/BFS17AW

Vishay Semiconductors

V <sub>CE</sub> /V	I <sub>C</sub> /mA	f/MHz	S11		S21		S12		S22	
			LIN MAG	ANG	LIN MAG	ANG	LIN MAG	ANG	LIN MAG	ANG
				deg		deg		deg		deg
10	10	100	0.492	-61.8	18.05	139.5	0.018	66.6	0.846	-16.3
		300	0.351	-126.2	9.08	106.1	0.034	62.3	0.628	-17.5
		500	0.321	-153.8	5.81	92.9	0.047	67.0	0.584	-15.3
		800	0.310	-175.0	3.77	80.8	0.069	71.5	0.573	-15.4
		1000	0.316	174.4	3.06	74.6	0.084	73.1	0.575	-17.0
		1200	0.324	166.7	2.60	68.9	0.100	74.0	0.575	-19.5
		1500	0.344	157.6	2.15	61.3	0.124	74.8	0.575	-23.5
		1800	0.362	149.3	1.85	54.3	0.149	75.0	0.572	-28.1
	2000	0.380	143.7	1.70	49.6	0.167	74.3	0.571	-31.3	
	15	100	0.411	-76.1	21.04	133.5	0.016	66.5	0.799	-17.7
		300	0.318	-140.0	9.59	102.1	0.031	67.0	0.596	-15.9
		500	0.305	-162.9	6.01	90.2	0.046	71.4	0.565	-13.5
		800	0.302	178.7	3.87	79.1	0.070	74.7	0.563	-14.1
		1000	0.304	170.3	3.14	73.2	0.085	75.5	0.565	-15.8
		1200	0.318	163.9	2.67	67.8	0.102	75.8	0.569	-18.2
		1500	0.336	155.2	2.19	60.4	0.126	75.9	0.568	-22.5
		1800	0.360	147.7	1.89	53.8	0.151	75.6	0.567	-27.0
	2000	0.376	142.5	1.73	49.0	0.169	75.0	0.564	-30.4	
	20	100	0.365	-88.4	22.59	129.0	0.014	65.8	0.765	-18.1
		300	0.311	-149.1	9.67	99.5	0.029	69.8	0.586	-14.4
		500	0.305	-169.0	6.00	88.5	0.045	73.6	0.564	-12.3
		800	0.305	175.4	3.85	78.0	0.069	76.2	0.564	-13.3
		1000	0.312	167.2	3.12	72.4	0.085	76.9	0.570	-15.1
		1200	0.322	161.4	2.65	66.9	0.102	76.8	0.571	-17.8
1500		0.344	154.1	2.18	59.6	0.126	76.6	0.571	-22.1	
1800		0.366	146.6	1.87	52.9	0.151	76.2	0.570	-26.9	
2000	0.381	141.8	1.72	48.3	0.170	75.5	0.568	-30.1		

### Typical Characteristics ( $T_{amb} = 25^{\circ}\text{C}$ unless otherwise specified)

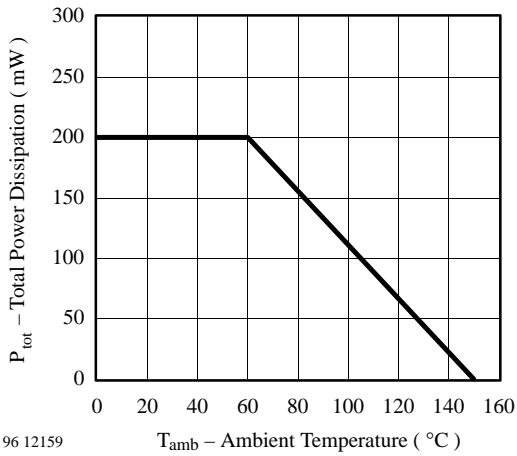

Figure 1. Total Power Dissipation vs. Ambient Temperature

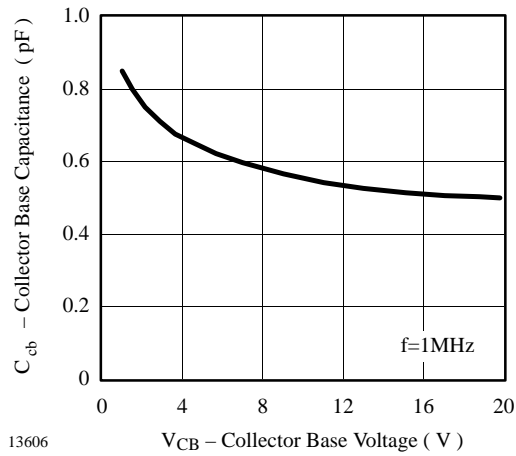

Figure 3. Collector Base Capacitance vs. Collector Base Voltage

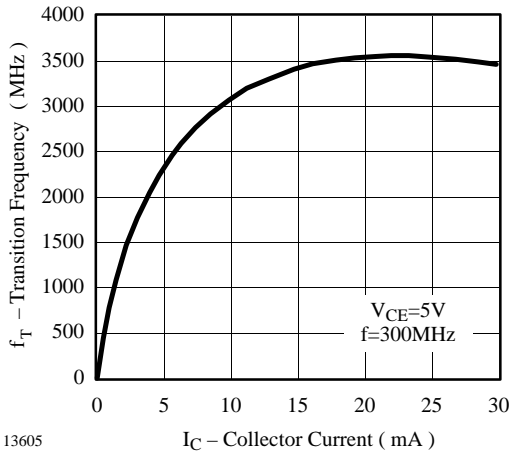

Figure 2. Transition Frequency vs. Collector Current

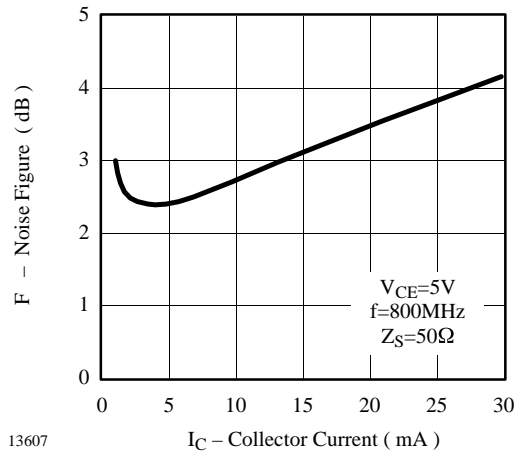

Figure 4. Noise Figure vs. Collector Current

$V_{CE} = 8 \text{ V}$ ,  $I_C = 25 \text{ mA}$ ,  $Z_0 = 50 \Omega$

$S_{11}$

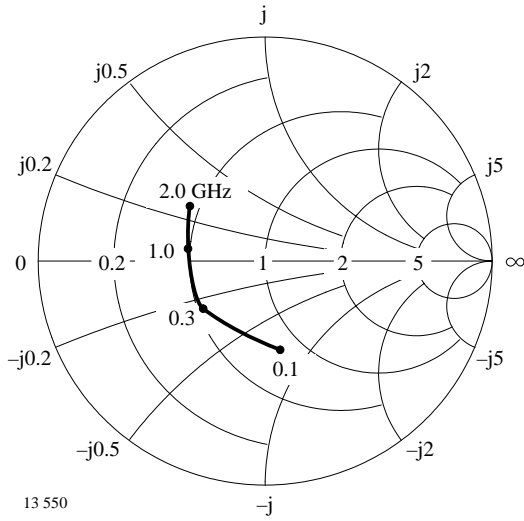

Figure 5. Input reflection coefficient

$S_{12}$

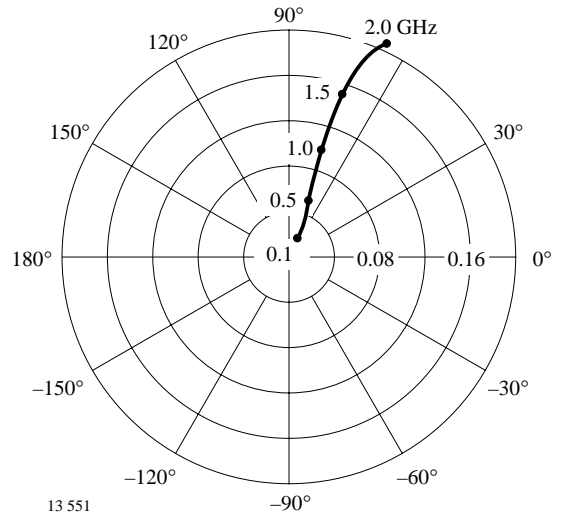

Figure 7. Reverse transmission coefficient

$S_{21}$

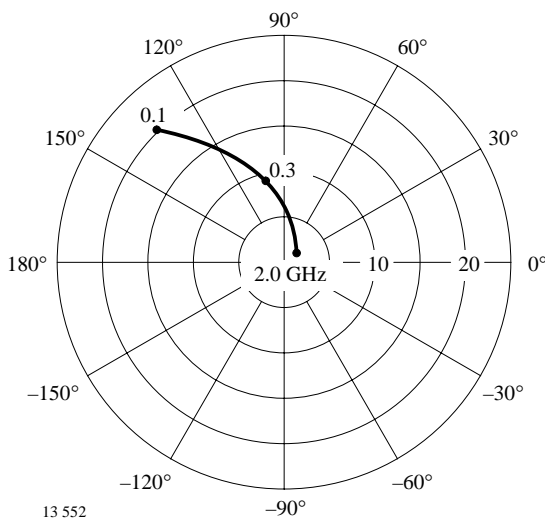

Figure 6. Forward transmission coefficient

$S_{22}$

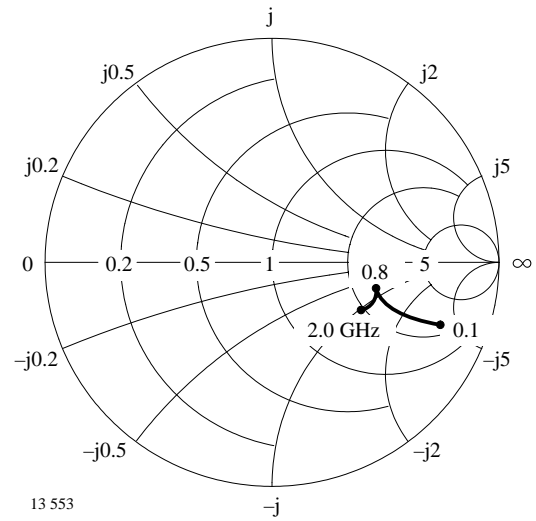
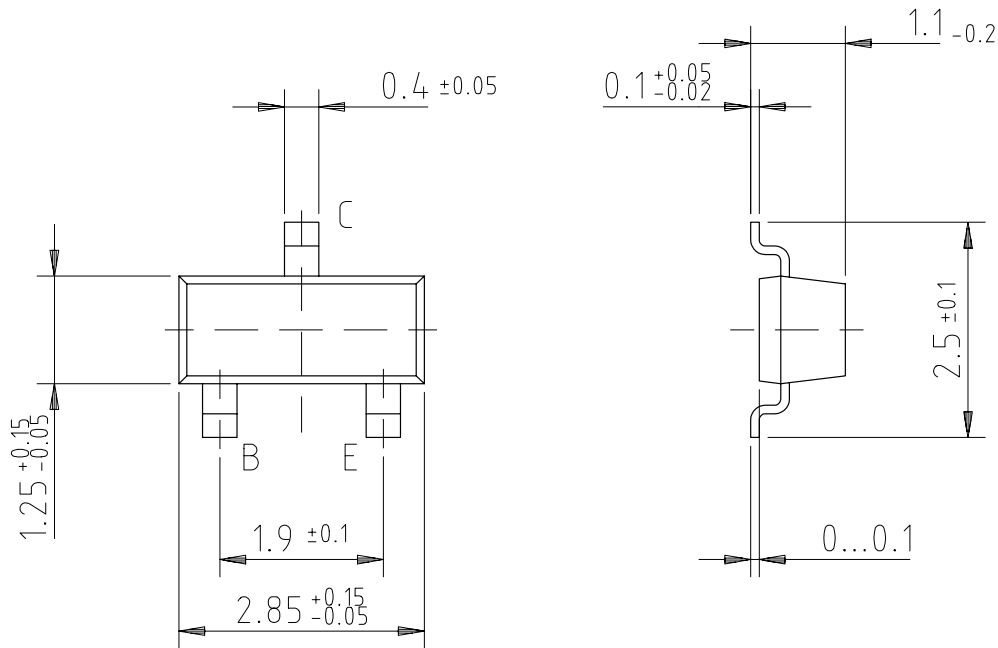
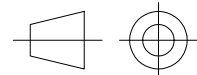

Figure 8. Output reflection coefficient

### Dimensions of BFS17A in mm



95 11346



technical drawings  
according to DIN  
specifications

### Dimensions of BFS17AR in mm

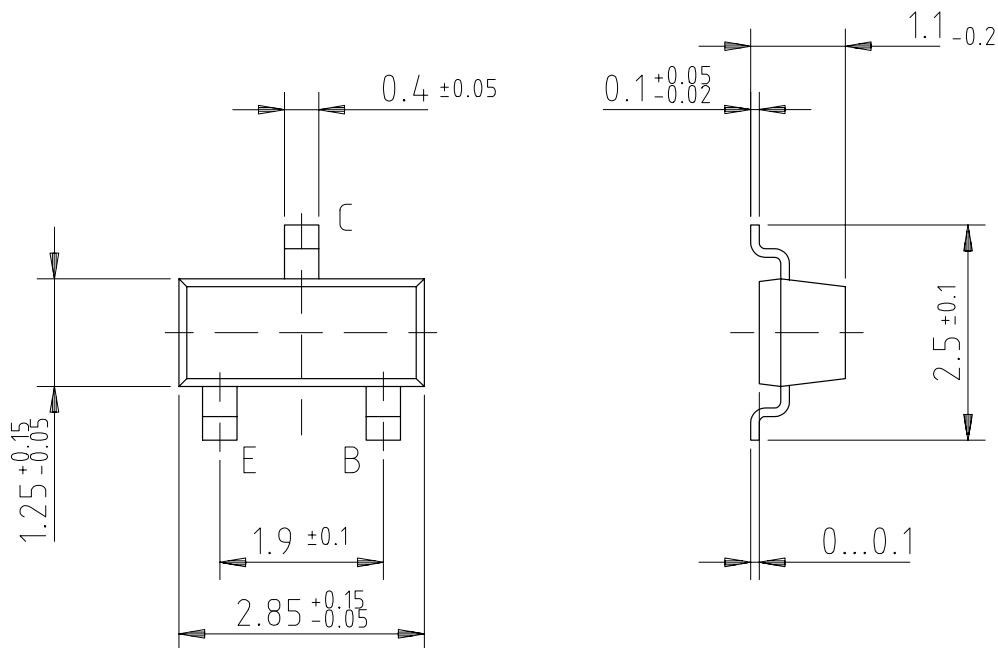

95 11347

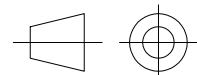

technical drawings  
according to DIN  
specifications



## Dimensions of BFS17AW in mm

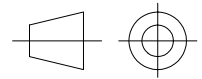
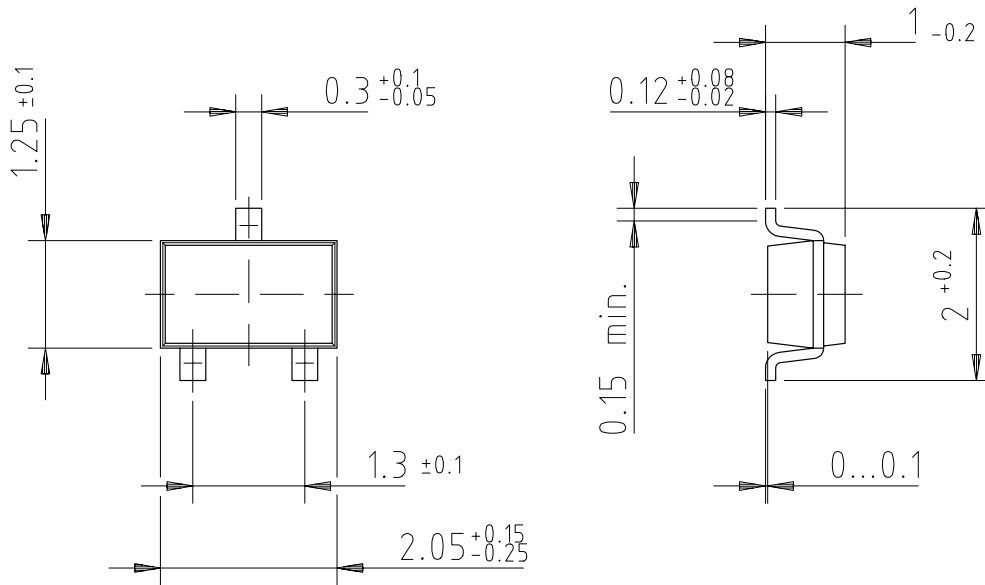

technical drawings  
according to DIN  
specifications

96 12236

### Ozone Depleting Substances Policy Statement

It is the policy of **Vishay Semiconductor GmbH** to

1. Meet all present and future national and international statutory requirements.
2. Regularly and continuously improve the performance of our products, processes, distribution and operating systems with respect to their impact on the health and safety of our employees and the public, as well as their impact on the environment.

It is particular concern to control or eliminate releases of those substances into the atmosphere which are known as ozone depleting substances (ODSs).

The Montreal Protocol (1987) and its London Amendments (1990) intend to severely restrict the use of ODSs and forbid their use within the next ten years. Various national and international initiatives are pressing for an earlier ban on these substances.

**Vishay Semiconductor GmbH** has been able to use its policy of continuous improvements to eliminate the use of ODSs listed in the following documents.

1. Annex A, B and list of transitional substances of the Montreal Protocol and the London Amendments respectively
2. Class I and II ozone depleting substances in the Clean Air Act Amendments of 1990 by the Environmental Protection Agency (EPA) in the USA
3. Council Decision 88/540/EEC and 91/690/EEC Annex A, B and C (transitional substances) respectively.

**Vishay Semiconductor GmbH** can certify that our semiconductors are not manufactured with ozone depleting substances and do not contain such substances.

**We reserve the right to make changes to improve technical design and may do so without further notice.**

Parameters can vary in different applications. All operating parameters must be validated for each customer application by the customer. Should the buyer use Vishay-Semiconductors products for any unintended or unauthorized application, the buyer shall indemnify Vishay-Semiconductors against all claims, costs, damages, and expenses, arising out of, directly or indirectly, any claim of personal damage, injury or death associated with such unintended or unauthorized use.

Vishay Semiconductor GmbH, P.O.B. 3535, D-74025 Heilbronn, Germany  
Telephone: 49 (0)7131 67 2831, Fax number: 49 (0)7131 67 2423



LittleDiode supplies new, hard to find or obsolete electronic components and semiconductors all over the world.

With over two million different components listed you are sure to find the part you need.

Feel free to visit us today at our online store:

[LittleDiode.com](http://LittleDiode.com)

Looking forward to providing you with the best possible service.