

**NPN Silicon RF Transistor**
**Preliminary data**

- For broadband amplifiers up to 2 GHz and fast non-saturated switches at collector currents from 0.5 mA to 20 mA
- Complementary type: BFT92T (PNP)

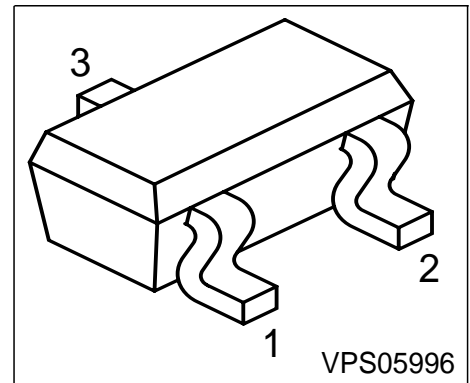

**ESD:** Electrostatic discharge sensitive device, observe handling precaution!

Type	Marking	Pin Configuration			Package
BFR92T	GFs	1 = B	2 = E	3 = C	SC75

**Maximum Ratings**

Parameter	Symbol	Value	Unit
Collector-emitter voltage	$V_{CEO}$	15	V
Collector-emitter voltage	$V_{CES}$	20	
Collector-base voltage	$V_{CBO}$	20	
Emitter-base voltage	$V_{EBO}$	2.5	
Collector current	$I_C$	30	mA
Base current	$I_B$	4	
Total power dissipation $T_S \leq 69^\circ\text{C}^1)$	$P_{tot}$	280	mW
Junction temperature	$T_j$	150	°C
Ambient temperature	$T_A$	-65 ... 150	
Storage temperature	$T_{stg}$	-65 ... 150	

**Thermal Resistance**

Junction - soldering point <sup>2)</sup>	$R_{thJS}$	$\leq 290$	K/W
--	------------	------------	-----

<sup>1</sup>  $T_S$  is measured on the collector lead at the soldering point to the pcb

<sup>2</sup> For calculation of  $R_{thJA}$  please refer to Application Note Thermal Resistance

**Electrical Characteristics** at  $T_A = 25^\circ\text{C}$ , unless otherwise specified.

Parameter	Symbol	Values			Unit
		min.	typ.	max.	
<b>DC characteristics</b>					
Collector-emitter breakdown voltage $I_C = 1 \text{ mA}, I_B = 0$	$V_{(BR)CEO}$	15	-	-	V
Collector-emitter cutoff current $V_{CE} = 20 \text{ V}, V_{BE} = 0$	$I_{CES}$	-	-	10	$\mu\text{A}$
Collector-base cutoff current $V_{CB} = 10 \text{ V}, I_E = 0$	$I_{CBO}$	-	-	100	nA
Emitter-base cutoff current $V_{EB} = 2.5 \text{ V}, I_C = 0$	$I_{EBO}$	-	-	100	$\mu\text{A}$
DC current gain $I_C = 15 \text{ mA}, V_{CE} = 8 \text{ V}$	$h_{FE}$	40	100	200	-

**Electrical Characteristics** at  $T_A = 25^\circ\text{C}$ , unless otherwise specified.

Parameter	Symbol	Values			Unit
		min.	typ.	max.	
<b>AC characteristics</b> (verified by random sampling)					
Transition frequency $I_C = 15 \text{ mA}$ , $V_{CE} = 8 \text{ V}$ , $f = 500 \text{ MHz}$	$f_T$	3.5	5	-	GHz
Collector-base capacitance $V_{CB} = 10 \text{ V}$ , $f = 1 \text{ MHz}$	$C_{cb}$	-	0.38	0.6	pF
Collector-emitter capacitance $V_{CE} = 10 \text{ V}$ , $f = 1 \text{ MHz}$	$C_{ce}$	-	0.2	-	
Emitter-base capacitance $V_{EB} = 0.5 \text{ V}$ , $f = 1 \text{ MHz}$	$C_{eb}$	-	0.7	-	
Noise figure $I_C = 2 \text{ mA}$ , $V_{CE} = 6 \text{ V}$ , $Z_S = Z_{Sopt}$ , $f = 900 \text{ MHz}$ $f = 1.8 \text{ GHz}$	$F$	-	1.8 2.9	-	dB
Power gain, maximum available <sup>1)</sup> $I_C = 15 \text{ mA}$ , $V_{CE} = 8 \text{ V}$ , $Z_S = Z_{Sopt}$ , $Z_L = Z_{Lopt}$ , $f = 900 \text{ MHz}$ $f = 1.8 \text{ GHz}$	$G_{ma}$	-	16 10.5	-	
Transducer gain $I_C = 15 \text{ mA}$ , $V_{CE} = 8 \text{ V}$ , $Z_S = Z_L = 50\Omega$ , $f = 900 \text{ MHz}$ $f = 1.8 \text{ GHz}$	$ S_{21e} ^2$	-	13.5 8	-	

$$^1G_{ma} = |S_{21} / S_{12}| (k - (k^2 - 1)^{1/2})$$

**SPICE Parameters (Gummel-Poon Model, Berkley-SPICE 2G.6 Syntax) :**

**Transistor Chip Data**

IS =	0.1213	fA	BF =	94.733	-	NF =	1.0947	-
VAF =	30	V	IKF =	0.46227	A	ISE =	129.55	fA
NE =	1.9052	-	BR =	10.729	-	NR =	0.8983	-
VAR =	14.599	V	IKR =	0.01	A	ISC =	0.75557	fA
NC =	1.371	-	RB =	14.998	$\Omega$	IRB =	0.01652	mA
RBM =	7.8145	$\Omega$	RE =	0.29088	$\Omega$	RC =	0.13793	$\Omega$
CJE =	10.416	fF	VJE =	0.70618	V	MJE =	0.34686	-
TF =	26.796	ps	XTF =	0.3817	-	VTF =	0.32861	V
ITF =	4.4601	mA	PTF =	0	deg	CJC =	946.47	fF
VJC =	0.84079	V	MJC =	0.4085	-	XCJC =	0.13464	-
TR =	1.2744	ns	CJS =	0	fF	VJS =	0.75	V
MJS =	0	-	XTB =	0	-	EG =	1.11	eV
XTI =	3	-	FC =	0.99545	-	TNOM	300	K

All parameters are ready to use, no scaling is necessary.  
 Extracted on behalf of Infineon Technologies AG by:  
 Institut für Mobil-und Satellitentechnik (IMST)

**Package Equivalent Circuit:**

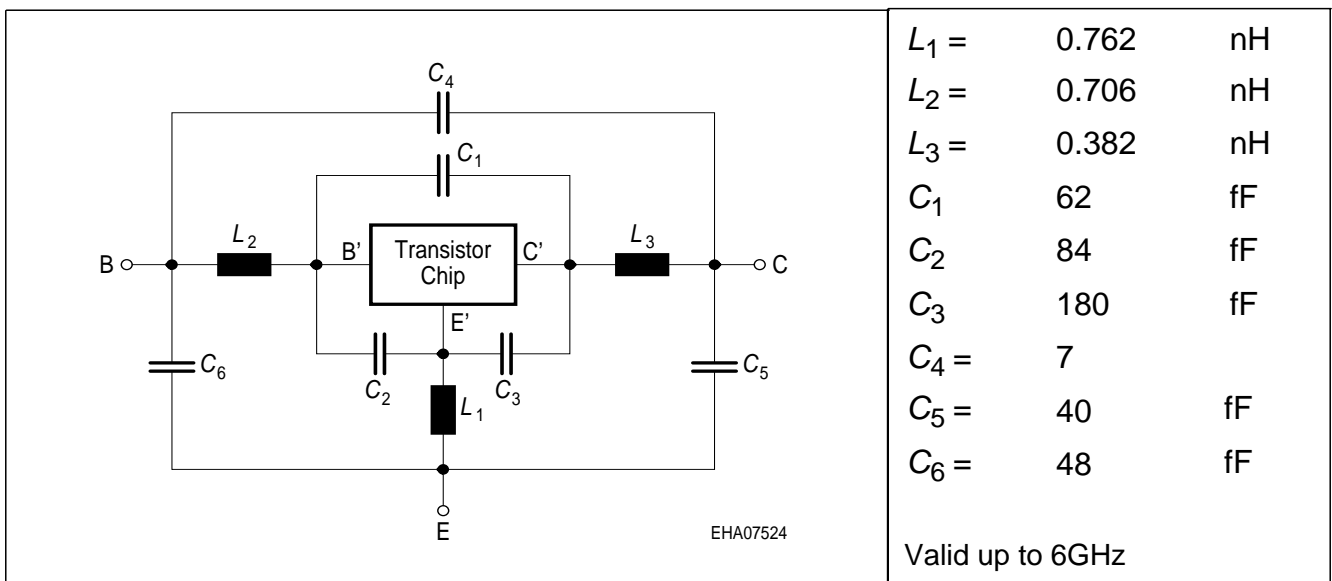

For examples and ready to use parameters please contact your local Infineon Technologies distributor or sales office to obtain a Infineon Technologies CD-ROM or see Internet: <http://www.infineon.com/silicondiscretes>

**Total power dissipation  $P_{tot} = f(T_S)$**

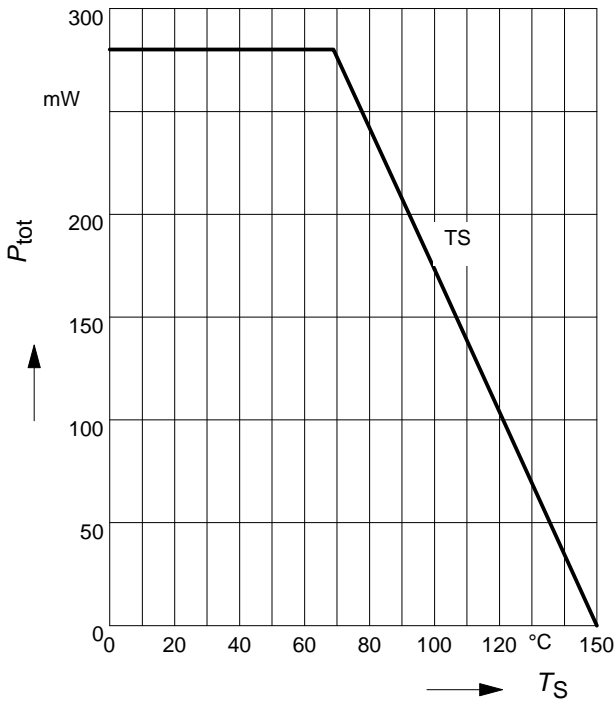

**Permissible Pulse Load  $R_{thJS} = f(t_p)$**

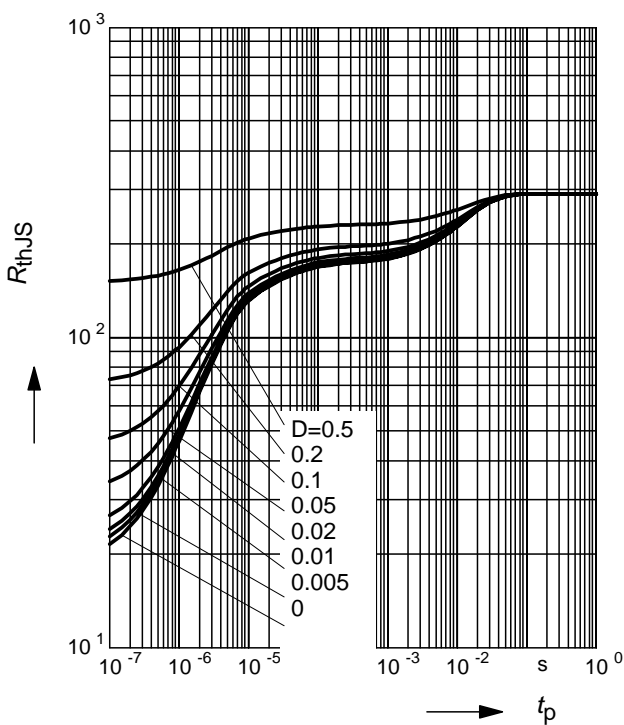

**Permissible Pulse Load**

$P_{totmax}/P_{totDC} = f(t_p)$

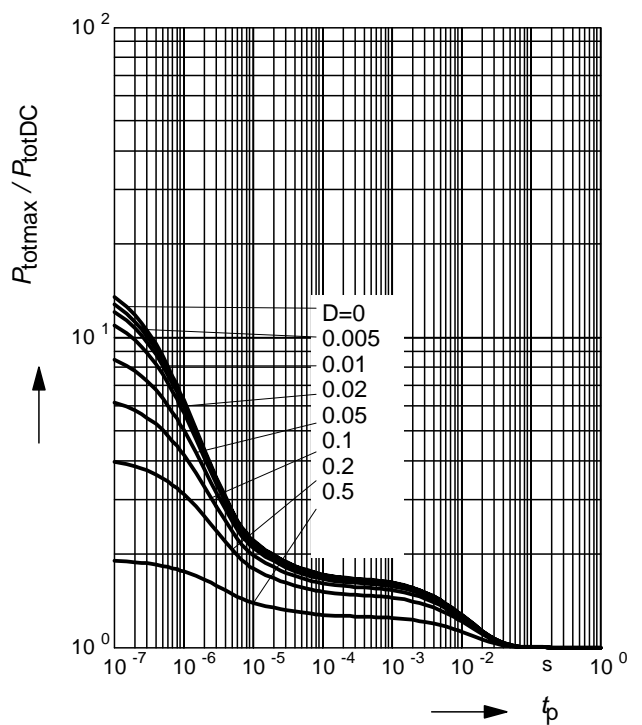

**Collector-base capacitance  $C_{cb} = f(V_{CB})$**

$f = 1\text{MHz}$

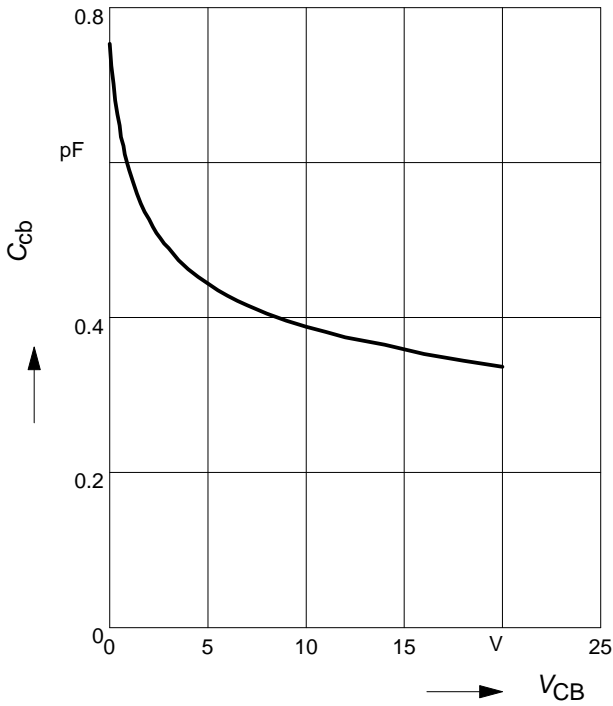

**Transition frequency  $f_T = f(I_C)$**

$V_{CE} = \text{Parameter}$

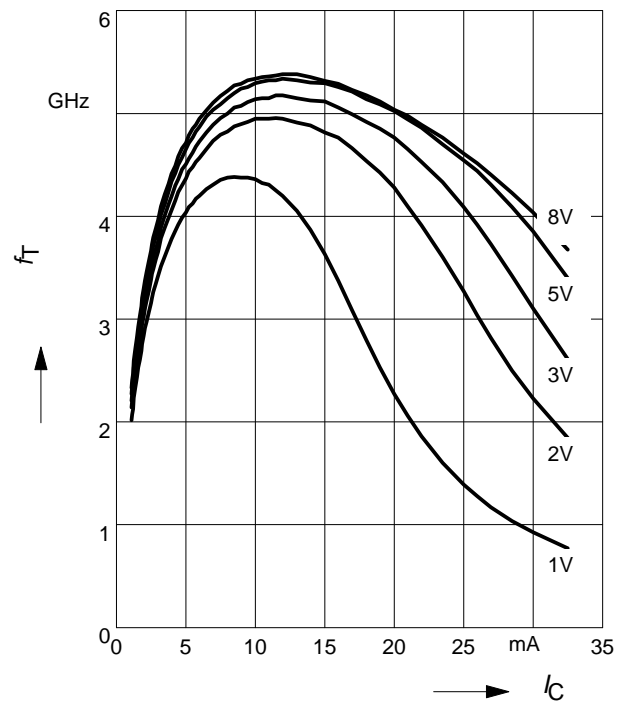

**Power Gain  $G_{ma}, G_{ms} = f(I_C)$**

$f = 0.9\text{GHz}$

$V_{CE} = \text{Parameter}$

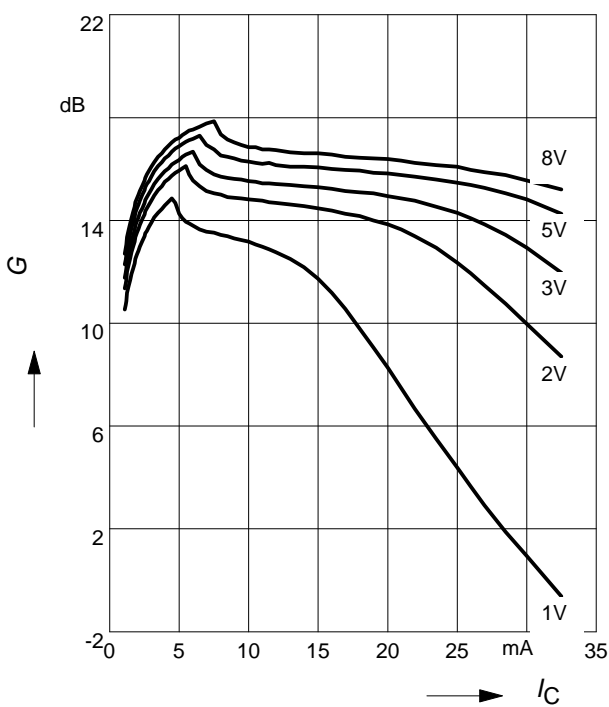

**Power Gain  $G_{ma}, G_{ms} = f(I_C)$**

$f = 1.8\text{GHz}$

$V_{CE} = \text{Parameter}$

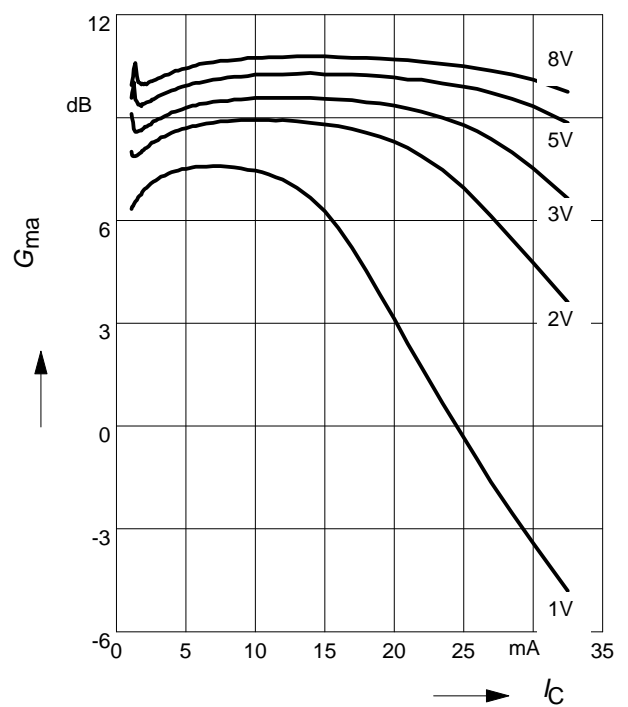

**Power Gain**  $G_{ma}, G_{ms} = f(V_{CE})$ : \_\_\_\_\_

$|S_{21}|^2 = f(V_{CE})$ : - - - - -

$f$  = Parameter

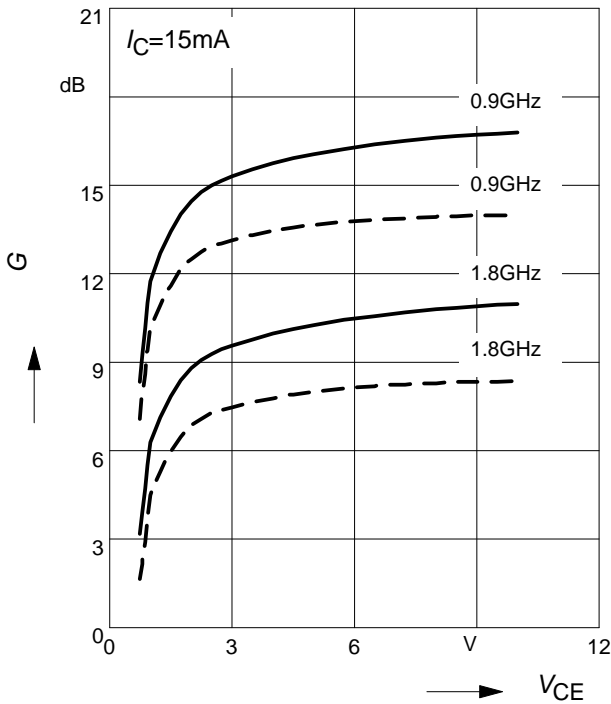

**Intermodulation Intercept Point**  $IP_3 = f(I_C)$

(3rd order, Output,  $Z_S = Z_L = 50\Omega$ )

$V_{CE}$  = Parameter,  $f = 900\text{MHz}$

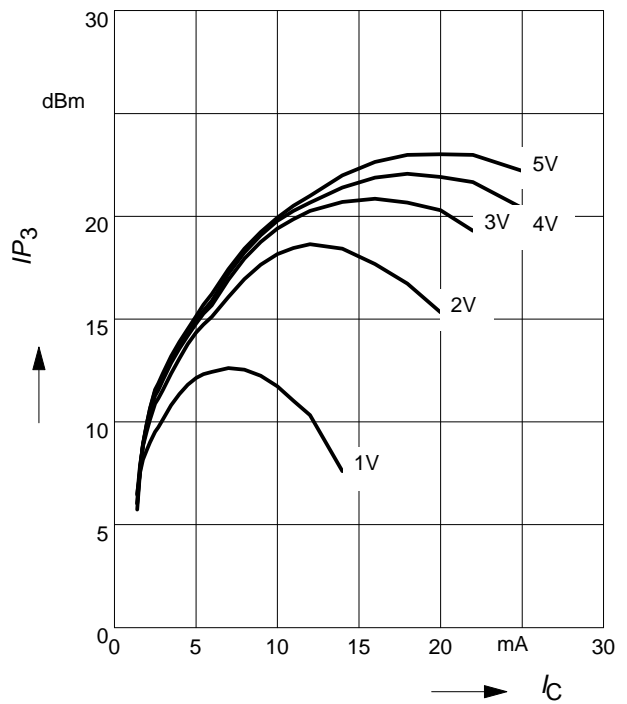

**Power Gain**  $G_{ma}, G_{ms} = f(f)$

$V_{CE}$  = Parameter

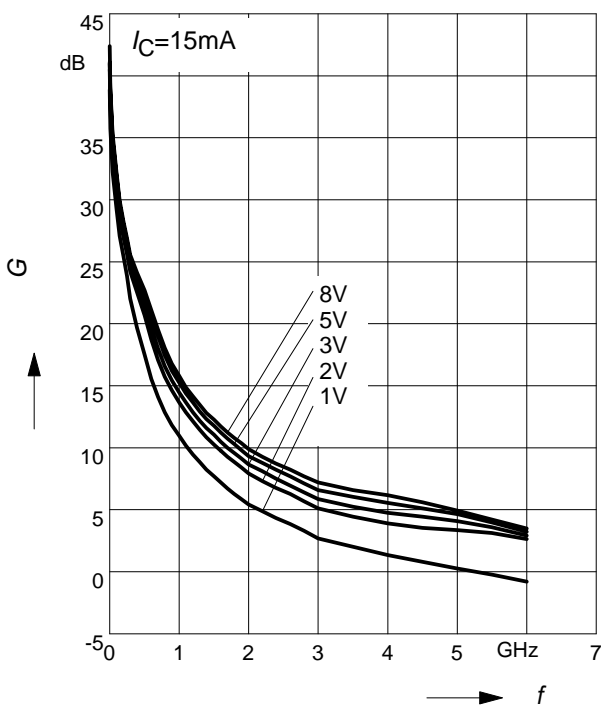

**Power Gain**  $|S_{21}|^2 = f(f)$

$V_{CE}$  = Parameter

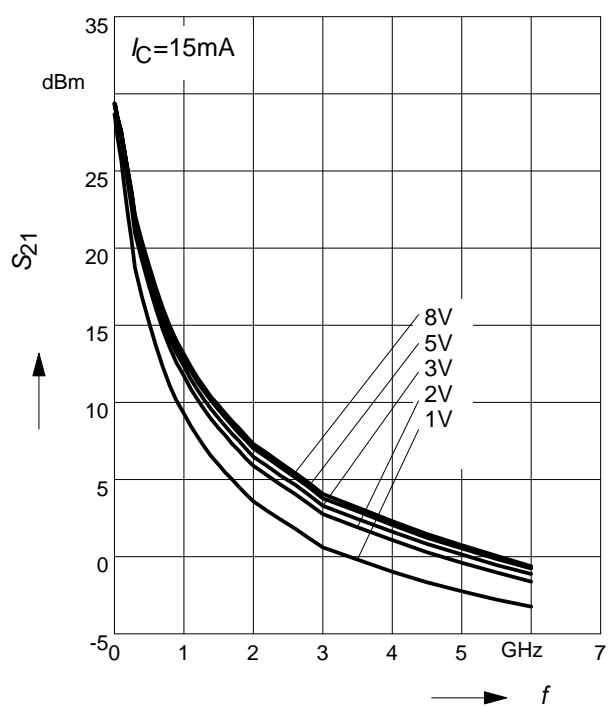



LittleDiode supplies new, hard to find or obsolete electronic components and semiconductors all over the world.

With over two million different components listed you are sure to find the part you need.

Feel free to visit us today at our online store:

[LittleDiode.com](http://LittleDiode.com)

Looking forward to providing you with the best possible service.