

**NPN Silicon Germanium RF Transistor\***

- High gain low noise RF transistor
- Small package 1.4 x 0.8 x 0.59 mm
- Outstanding noise figure  $F = 0.7$  dB at 1.8 GHz  
Outstanding noise figure  $F = 1.3$  dB at 6 GHz
- Maximum stable gain  
 $G_{ms} = 21$  dB at 1.8 GHz  
 $G_{ma} = 10$  dB at 6 GHz
- Gold metallization for extra high reliability

\*Short-term description

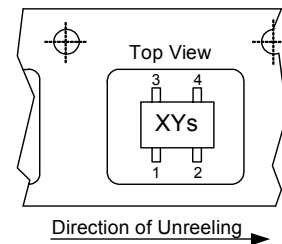
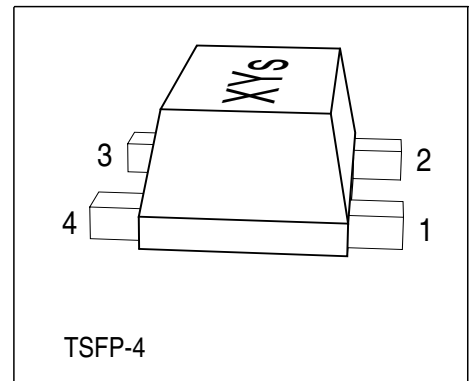

**ESD: Electrostatic discharge sensitive device, observe handling precaution!**

Type	Marking	Pin Configuration						Package
BFP620F	R2s	1=B	2=E	3=C	4=E	-	-	TSFP-4

**Maximum Ratings**

Parameter	Symbol	Value	Unit
Collector-emitter voltage	$V_{CEO}$		V
$T_A > 0$ °C		2.3	
$T_A \leq 0$ °C		2.1	
Collector-emitter voltage	$V_{CES}$	7.5	
Collector-base voltage	$V_{CBO}$	7.5	
Emitter-base voltage	$V_{EBO}$	1.2	
Collector current	$I_C$	80	mA
Base current	$I_B$	3	
Total power dissipation <sup>1)</sup>	$P_{tot}$	185	mW
$T_S \leq 96$ °C			
Junction temperature	$T_j$	150	°C
Ambient temperature	$T_A$	-65 ... 150	
Storage temperature	$T_{stg}$	-65 ... 150	

<sup>1</sup> $T_S$  is measured on the collector lead at the soldering point to the pcb

**Thermal Resistance**

Parameter	Symbol	Value	Unit
Junction - soldering point <sup>1)</sup>	$R_{thJS}$	$\leq 290$	K/W

**Electrical Characteristics at  $T_A = 25^\circ\text{C}$ , unless otherwise specified**

Parameter	Symbol	Values			Unit
		min.	typ.	max.	

**DC Characteristics**

Collector-emitter breakdown voltage $I_C = 1 \text{ mA}, I_B = 0$	$V_{(BR)CEO}$	2.3	2.8	-	V
Collector-emitter cutoff current $V_{CE} = 7.5 \text{ V}, V_{BE} = 0$	$I_{CES}$	-	-	10	$\mu\text{A}$
Collector-base cutoff current $V_{CB} = 5 \text{ V}, I_E = 0$	$I_{CBO}$	-	-	100	nA
Emitter-base cutoff current $V_{EB} = 0.5 \text{ V}, I_C = 0$	$I_{EBO}$	-	-	3	$\mu\text{A}$
DC current gain $I_C = 50 \text{ mA}, V_{CE} = 1.5 \text{ V}$ , pulse measured	$h_{FE}$	110	180	270	-

<sup>1)</sup>For calculation of  $R_{thJA}$  please refer to Application Note Thermal Resistance

**Electrical Characteristics at  $T_A = 25^\circ\text{C}$ , unless otherwise specified**

Parameter	Symbol	Values			Unit
		min.	typ.	max.	
<b>AC Characteristics (verified by random sampling)</b>					
Transition frequency $I_C = 50\text{ mA}$ , $V_{CE} = 1.5\text{ V}$ , $f = 1\text{ GHz}$	$f_T$	-	65	-	GHz
Collector-base capacitance $V_{CB} = 2\text{ V}$ , $f = 1\text{ MHz}$	$C_{cb}$	-	0.12	0.2	pF
Collector emitter capacitance $V_{CE} = 2\text{ V}$ , $f = 1\text{ MHz}$	$C_{ce}$	-	0.2	-	
Emitter-base capacitance $V_{EB} = 0.5\text{ V}$ , $f = 1\text{ MHz}$	$C_{eb}$	-	0.45	-	
Noise figure $I_C = 5\text{ mA}$ , $V_{CE} = 1.5\text{ V}$ , $f = 1.8\text{ GHz}$ , $Z_S = Z_{Sopt}$ $I_C = 5\text{ mA}$ , $V_{CE} = 1.5\text{ V}$ , $f = 6\text{ GHz}$ , $Z_S = Z_{Sopt}$	$F$	-	0.7 1.3	-	dB
Power gain, maximum stable <sup>1)</sup> $I_C = 50\text{ mA}$ , $V_{CE} = 1.5\text{ V}$ , $Z_S = Z_{Sopt}$ , $Z_L = Z_{Lopt}$ , $f = 1.8\text{ GHz}$	$G_{ms}$	-	21	-	dB
Power gain, maximum available <sup>1)</sup> $I_C = 50\text{ mA}$ , $V_{CE} = 1.5\text{ V}$ , $Z_S = Z_{Sopt}$ , $Z_L = Z_{Lopt}$ , $f = 6\text{ GHz}$	$G_{ma}$	-	10	-	dB
Transducer gain $I_C = 50\text{ mA}$ , $V_{CE} = 1.5\text{ V}$ , $Z_S = Z_L = 50\ \Omega$ , $f = 1.8\text{ GHz}$ $I_C = 50\text{ mA}$ , $V_{CE} = 1.5\text{ V}$ , $Z_S = Z_L = 50\ \Omega$ , $f = 6\text{ GHz}$	$ S_{21e} ^2$	-	19.5 9.5	-	dB
Third order intercept point at output <sup>2)</sup> $V_{CE} = 2\text{ V}$ , $I_C = 50\text{ mA}$ , $f = 1.8\text{ GHz}$ , $Z_S = Z_L = 50\ \Omega$	$IP_3$	-	25	-	dBm
1dB Compression point at output $I_C = 50\text{ mA}$ , $V_{CE} = 2\text{ V}$ , $Z_S = Z_L = 50\ \Omega$ , $f = 1.8\text{ GHz}$	$P_{-1dB}$	-	14	-	

<sup>1</sup> $G_{ma} = |S_{21e} / S_{12e}| (k - (k^2 - 1)^{1/2})$ ,  $G_{ms} = |S_{21e} / S_{12e}|$ 
<sup>2</sup> $IP_3$  value depends on termination of all intermodulation frequency components.  
Termination used for this measurement is  $50\ \Omega$  from 0.1 MHz to 6 GHz

**SPICE Parameter (Gummel-Poon Model, Berkley-SPICE 2G.6 Syntax):**
**Transistor Chip Data:**

IS =	0.22	fA	BF =	425	-	NF =	1.025	-
VAF =	1000	V	IKF =	0.25	A	ISE =	21	fA
NE =	2	-	BR =	50	-	NR =	1	-
VAR =	2	V	IKR =	10	mA	ISC =	18	pA
NC =	2	-	RB =	3.129	$\Omega$	IRB =	1.522	mA
RBM =	2.707	$\Omega$	RE =	0.6	-	RC =	2.364	$\Omega$
CJE =	250.7	fF	VJE =	0.75	V	MJE =	0.3	-
TF =	1.43	ps	XTF =	10	-	VTF =	1.5	V
ITF =	2.4	A	PTF =	0	deg	CJC =	124.9	fF
VJC =	0.6	V	MJC =	0.5	-	XCJC =	1	-
TR =	0.2	ns	CJS =	128.1	fF	VJS =	0.52	V
MJS =	0.5	-	NK =	-1.42	-	EG =	1.078	eV
XTI =	3	-	FC =	0.8	-	TNOM	298	K
AF =	2	-	KF =	7.291E-11	-			
TITF1	-0.0065	-	TITF2	1.0E-5	-			

All parameters are ready to use, no scaling is necessary.

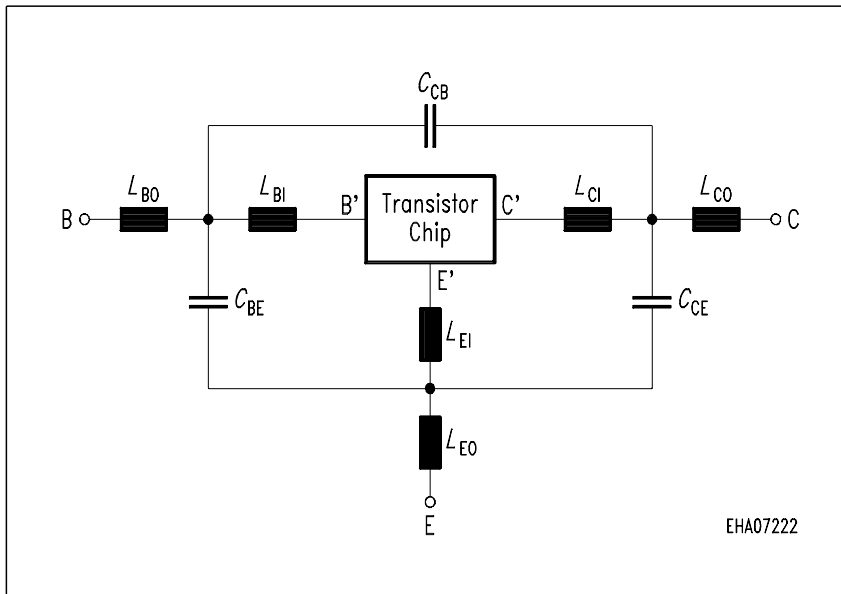
**Package Equivalent Circuit:**

To avoid high complexity of the package equivalent circuit, both emitter leads of TSFP-4 are combined in one electrical connection.  $R_{Lx}$  are series resistors for the inductances  $L_{x1}$  and  $K_{xa-yb}$  are the coupling coefficients between the inductances  $L_{xa}$  and  $L_{yb}$ .

$L_{B0}$ =	0.22	nH
$L_{E0}$ =	0.28	nH
$L_{C0}$ =	0.22	nH
$K_{B0-E0}$ =	0.1	-
$K_{B0-C0}$ =	0.01	-
$K_{E0-C0}$ =	0.11	-
$C_{BE}$ =	34	fF
$C_{BC}$ =	2	fF
$C_{CE}$ =	33	fF
$L_{BI}$ =	0.42	nH
$R_{LBI}$ =	0.15	$\Omega$
$L_{EI}$ =	0.26	nH
$R_{LEI}$ =	0.11	$\Omega$
$L_{CI}$ =	0.35	nH
$R_{LI}$ =	0.13	$\Omega$
$K_{BI-EI}$ =	-0.05	-
$K_{BI-CI}$ =	-0.08	-
$K_{EI-CI}$ =	0.2	-

Valid up to 6GHz

**Total power dissipation  $P_{tot} = f(T_S)$**

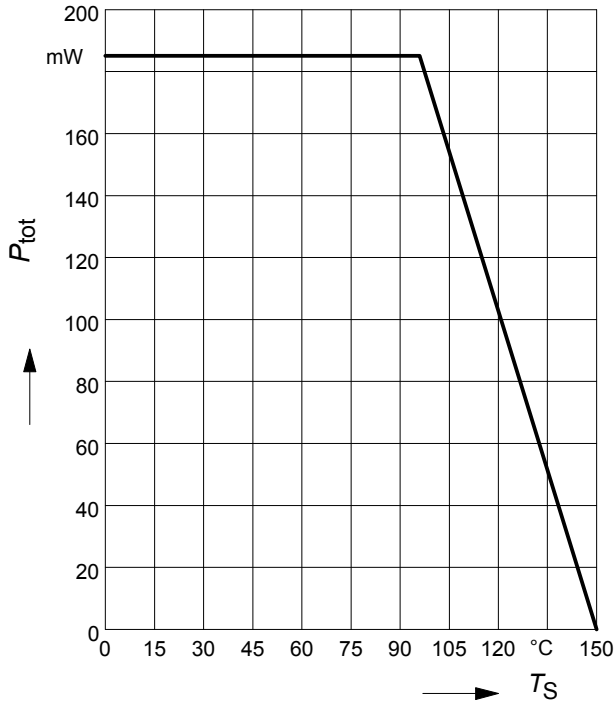

**Permissible Pulse Load  $R_{thJS} = f(t_p)$**

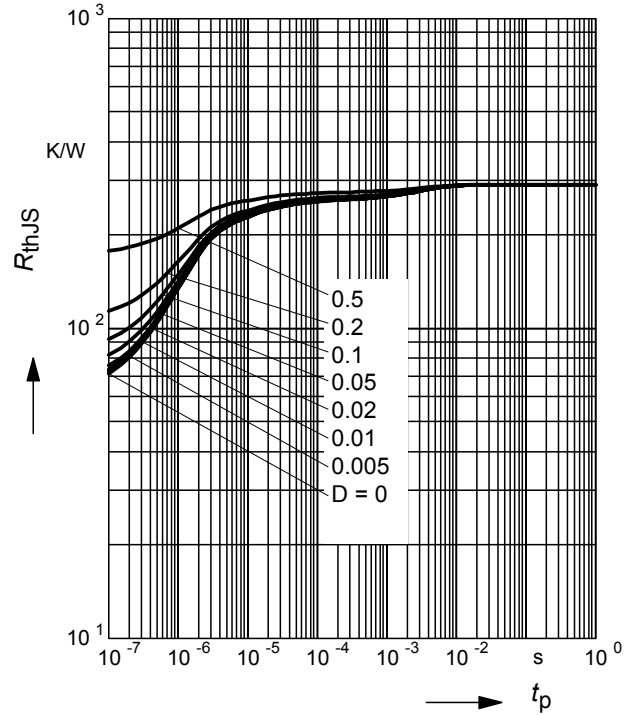

**Permissible Pulse Load**

$P_{totmax}/P_{totDC} = f(t_p)$

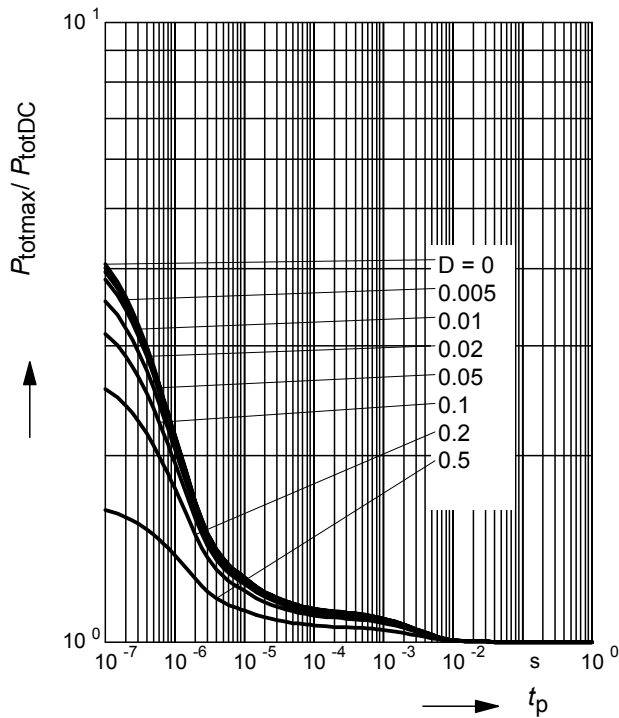

**Collector-base capacitance  $C_{cb} = f(V_{CB})$**

$f = 1\text{MHz}$

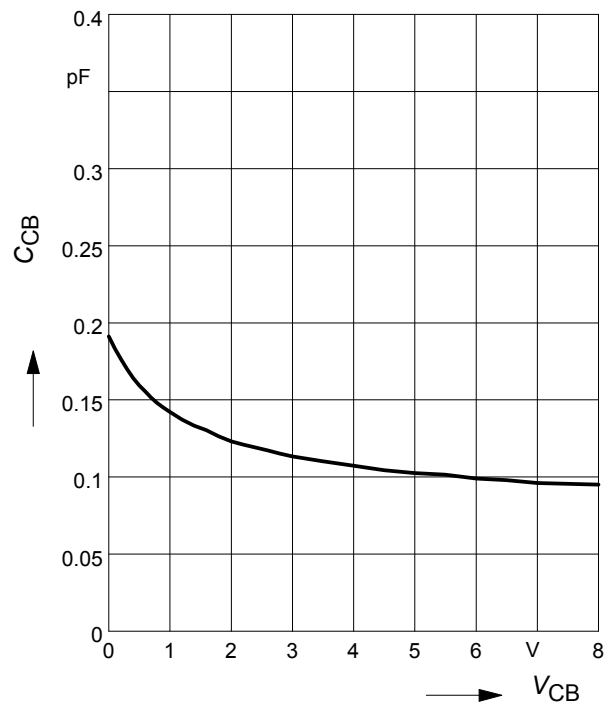

**Transition frequency  $f_T = f(I_C)$**

$f = 1\text{GHz}$

$V_{CE} = \text{Parameter in V}$

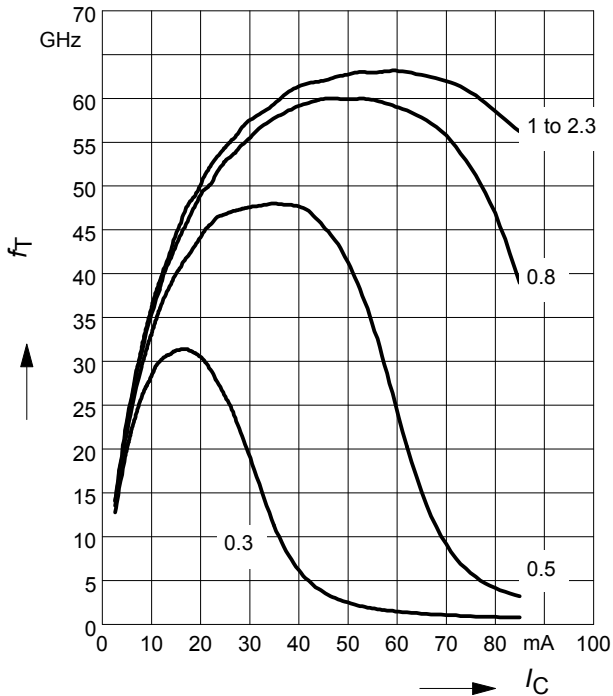

**Power gain  $G_{ma}, G_{ms} = f(I_C)$**

$V_{CE} = 1.5\text{V}$

$f = \text{Parameter in GHz}$

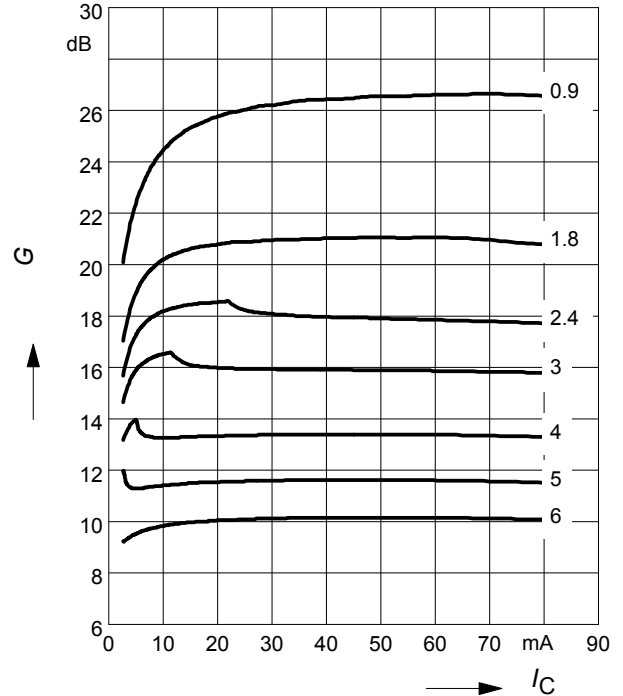

**Power Gain  $G_{ma}, G_{ms} = f(f)$ ,**

$|S_{21}|^2 = f(f)$

$V_{CE} = 1.5\text{V}, I_C = 50\text{mA}$

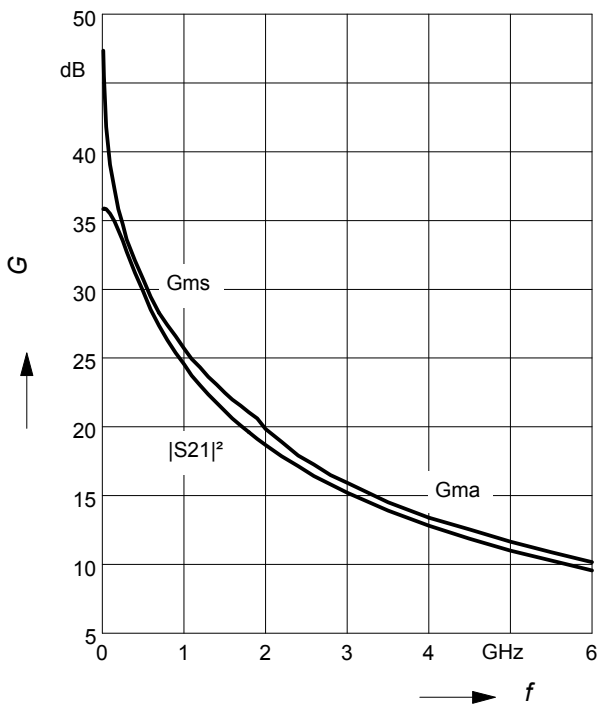

**Power gain  $G_{ma}, G_{ms} = f(V_{CE})$**

$I_C = 50\text{mA}$

$f = \text{Parameter in GHz}$

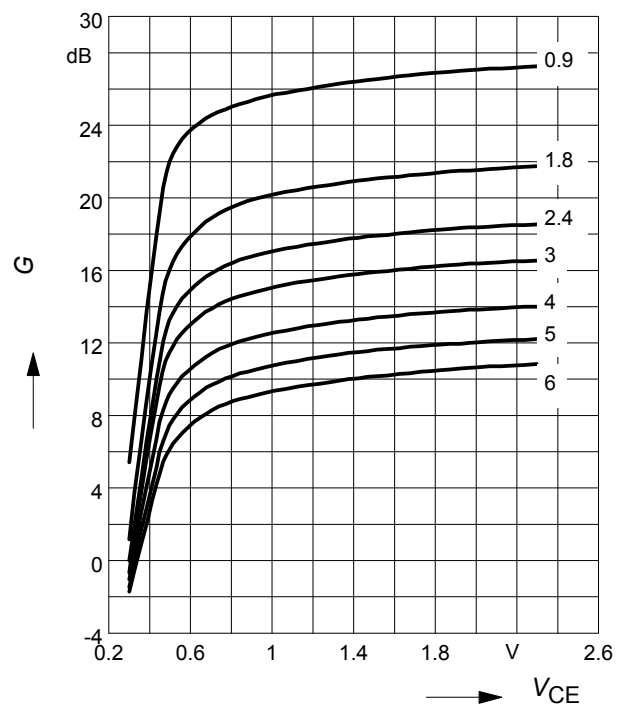

This datasheet has been downloaded from:

[www.DatasheetCatalog.com](http://www.DatasheetCatalog.com)

Datasheets for electronic components.



LittleDiode supplies new, hard to find or obsolete electronic components and semiconductors all over the world.

With over two million different components listed you are sure to find the part you need.

Feel free to visit us today at our online store:

[LittleDiode.com](http://LittleDiode.com)

Looking forward to providing you with the best possible service.