

NPN Silicon RF Transistor
Preliminary data

- For highest gain low noise amplifier at 1.8 GHz and 2 mA / 2 V

Outstanding $G_{ms} = 23$ dB

Noise Figure $F = 0.95$ dB

- For oscillators up to 15 GHz
- Transition frequency $f_T = 45$ GHz
- Gold metallization for high reliability
- **SIEGET® 45 - Line**
45 GHz f_T - Line

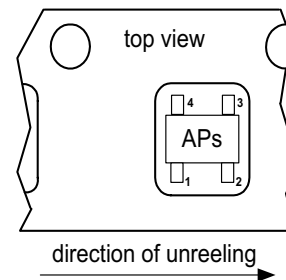
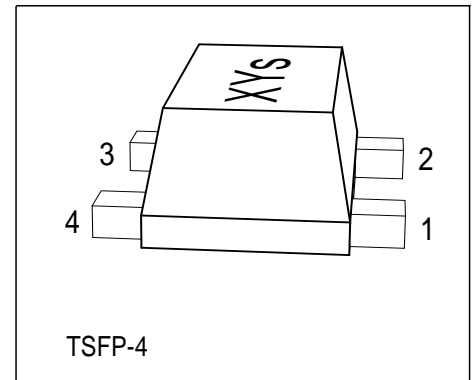

ESD: Electrostatic discharge sensitive device, observe handling precaution!

Type	Marking	Pin Configuration				Package
BFP520F	APs	1 = B	2 = E	3 = C	4 = E	TSFP-4

Maximum Ratings

Parameter	Symbol	Value	Unit
Collector-emitter voltage	V_{CEO}	2.5	V
Collector-base voltage	V_{CBO}	10	
Emitter-base voltage	V_{EBO}	1	
Collector current	I_C	40	mA
Base current	I_B	4	
Total power dissipation $T_S \leq 107^\circ\text{C}$	P_{tot}	100	mW
Junction temperature	T_j	150	°C
Ambient temperature	T_A	-65 ... 150	
Storage temperature	T_{stg}	-65 ... 150	

Thermal Resistance

Junction - soldering point ¹⁾	R_{thJS}	≤ 430	K/W
--	------------	------------	-----

¹⁾For calculation of R_{thJA} please refer to Application Note Thermal Resistance

Electrical Characteristics at $T_A = 25^\circ\text{C}$, unless otherwise specified.

Parameter	Symbol	Values			Unit
		min.	typ.	max.	
DC characteristics					
Collector-emitter breakdown voltage $I_C = 1 \text{ mA}, I_B = 0$	$V_{(BR)CEO}$	2.5	3	3.5	V
Collector-base cutoff current $V_{CB} = 5 \text{ V}, I_E = 0$	I_{CBO}	-	-	200	nA
Emitter-base cutoff current $V_{EB} = 1 \text{ V}, I_C = 0$	I_{EBO}	-	-	35	μA
DC current gain $I_C = 20 \text{ mA}, V_{CE} = 2 \text{ V}$	h_{FE}	70	110	200	-
AC characteristics (verified by random sampling)					
Transition frequency $I_C = 30 \text{ mA}, V_{CE} = 2 \text{ V}, f = 2 \text{ GHz}$	f_T	-	45	-	GHz
Collector-base capacitance $V_{CB} = 2 \text{ V}, f = 1 \text{ MHz}$	C_{cb}	-	0.07	-	pF
Collector-emitter capacitance $V_{CE} = 2 \text{ V}, f = 1 \text{ MHz}$	C_{ce}	-	0.25	-	
Emitter-base capacitance $V_{EB} = 0.5 \text{ V}, f = 1 \text{ MHz}$	C_{eb}	-	0.31	-	
Noise figure $I_C = 2 \text{ mA}, V_{CE} = 2 \text{ V}, Z_S = Z_{Sopt}, f = 1.8 \text{ GHz}$	F	-	0.95	-	dB
Power gain, maximum stable ¹⁾ $I_C = 20 \text{ mA}, V_{CE} = 2 \text{ V}, Z_S = Z_{Sopt}, Z_L = Z_{Lopt}, f = 1.8 \text{ GHz}$	G_{ms}	-	23	-	
Insertion power gain $I_C = 20 \text{ mA}, V_{CE} = 2 \text{ V}, f = 1.8 \text{ GHz}, Z_S = Z_L = 50\Omega$	$ S_{21} ^2$	-	20.5	-	dBm
Third order intercept point at output ²⁾ $V_{CE} = 2 \text{ V}, f = 1.8 \text{ GHz}, Z_S = Z_L = 50\Omega, I_C = 20 \text{ mA}$	IP_3	-	23.5	-	
1dB compression point ³⁾ $V_{CE} = 2 \text{ V}, f = 1.8 \text{ GHz}, Z_S = Z_L = 50\Omega, I_C = 20 \text{ mA}$	P_{-1dB}	-	10.5	-	

$$^1G_{ms} = |S_{21} / S_{12}|$$

² IP_3 value depends on termination of all intermodulation frequency components. Termination used for this measurement is 50Ω from 0.1MHz to 6GHz.

³DC current at no input power

SPICE Parameters (Gummel-Poon Model, Berkley-SPICE 2G.6 Syntax) :
Transistor Chip Data

IS =	15	aA	BF =	235	-	NF =	1	-
VAF =	25	V	IKF =	0.4	A	ISE =	25	fA
NE =	2	-	BR =	1.5	-	NR =	1	-
VAR =	2	V	IKR =	0.01	A	ISC =	20	fA
NC =	2	-	RB =	11	Ω	IRB =	-	A
RBM =	7.5	Ω	RE =	0.6		RC =	7.6	Ω
CJE =	235	fF	VJE =	0.958	V	MJE =	0.335	-
TF =	1.7	ps	XTF =	10	-	VTF =	5	V
ITF =	0.7	mA	PTF =	50	deg	CJC =	93	fF
VJC =	0.661	V	MJC =	0.236	-	XCJC =	1	-
TR =	50	ns	CJS =	0	fF	VJS =	0.75	V
MJS =	0.333	-	XTB =	-0.25	-	EG =	1.11	eV
XTI =	0.035	-	FC =	0.5	-	TNOM	298	K

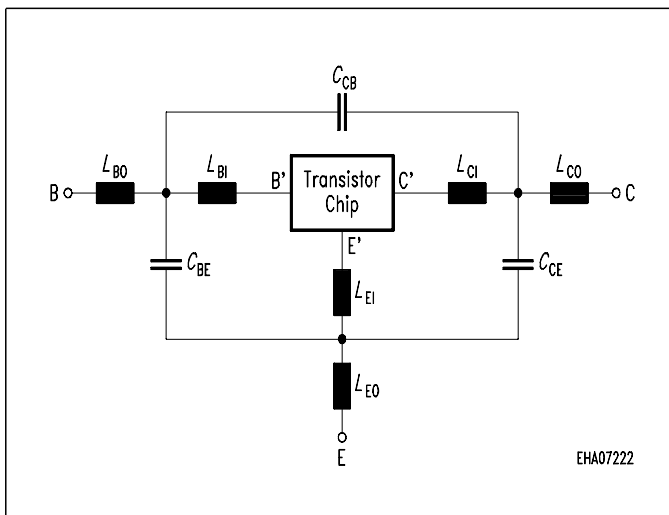
Package Equivalent Circuit:

$L_{BO} =$	0.22	nH	$L_{BI} =$	0.42	nH
$L_{EO} =$	0.28	nH	$R_{LBI} =$	0.15	Ω
$L_{CO} =$	0.22	nH	$L_{EI} =$	0.26	nH
$K_{BO-EO} =$	0.10	-	$R_{LEI} =$	0.11	Ω
$K_{BO-CO} =$	0.01	-	$L_{CI} =$	0.35	nH
$K_{EO-CO} =$	0.11	-	$R_{LCI} =$	0.13	Ω
$C_{BE} =$	34	fF	$K_{CI-EI} =$	-0.05	-
$C_{BC} =$	2	fF	$K_{BI-CI} =$	-0.08	-
$C_{CE} =$	33	fF	$K_{BI-EI} =$	0.20	-

Valid up to 6GHz

The TSFP-4 package has two emitter leads. To avoid high complexity of the package equivalent circuit, both leads are combined in one electrical connection.

R_{LXI} are series resistors for the inductances L_{XI} and K_{xa-yb} are the coupling coefficients between the inductances L_{xa} and L_{yb} . The referencepins for the coupled ports are B, E, C, B', E', C'.

For examples and ready to use parameters please contact your local Infineon Technologies distributor or sales office to obtain a Infineon Technologies CD-ROM or see Internet:
<http://www.infineon.com/silicondiscretetes>



LittleDiode supplies new, hard to find or obsolete electronic components and semiconductors all over the world.

With over two million different components listed you are sure to find the part you need.

Feel free to visit us today at our online store:

LittleDiode.com

Looking forward to providing you with the best possible service.