

Darlington Complementary Silicon Power Transistors

...designed for general purpose and low speed switching applications.

- High DC Current Gain – $h_{FE} = 2500$ (typ.) @ $I_C = 5.0$ Adc.
- Collector Emitter Sustaining Voltage @ 30 mAdc:
 - $V_{CEO(sus)} = 80$ Vdc (min.) — BDW46
 - 100 Vdc (min.) — BDW42/BDW47
- Low Collector Emitter Saturation Voltage
 - $V_{CE(sat)} = 2.0$ Vdc (max.) @ $I_C = 5.0$ Adc
 - 3.0 Vdc (max.) @ $I_C = 10.0$ Adc
- Monolithic Construction with Built-In Base Emitter Shunt resistors
- TO-220AB Compact Package

MAXIMUM RATINGS

Rating	Symbol	BDW46	BDW42 BDW47	Unit
Collector–Emitter Voltage	V_{CEO}	80	100	Vdc
Collector–Base Voltage	V_{CB}	80	100	Vdc
Emitter–Base Voltage	V_{EB}	5.0		Vdc
Collector Current — Continuous	I_C	15		Adc
Base Current	I_B	0.5		Adc
Total Device Dissipation @ $T_C = 25^\circ\text{C}$ Derate above 25°C	P_D	85 0.68		Watts W/ $^\circ\text{C}$
Operating and Storage Junction Temperature Range	T_J, T_{stg}	–55 to +150		$^\circ\text{C}$

THERMAL CHARACTERISTICS

Characteristic	Symbol	Max	Unit
Thermal Resistance, Junction to Case	$R_{\theta JC}$	1.47	$^\circ\text{C/W}$

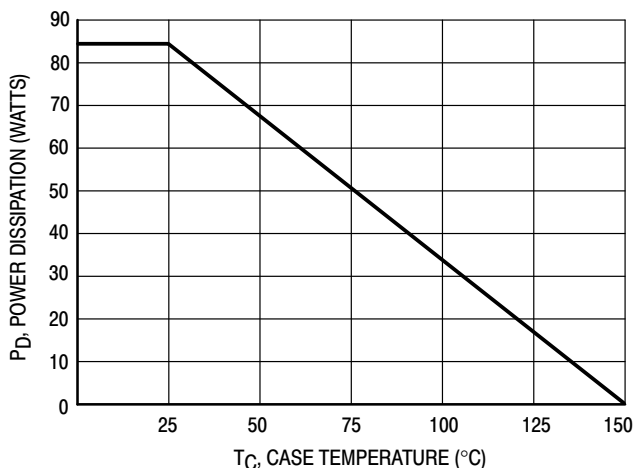
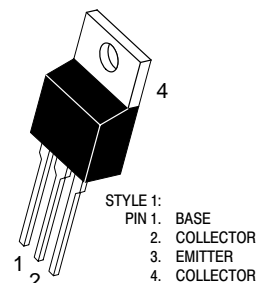

Figure 1. Power Temperature Derating Curve

**NPN
BDW42***
**PNP
BDW46**
BDW47*

*ON Semiconductor Preferred Device

**DARLINGTON
15 AMPERE
COMPLEMENTARY
SILICON
POWER TRANSISTORS
80–100 VOLTS
85 WATTS**



**CASE 221A-09
TO-220AB**

Preferred devices are ON Semiconductor recommended choices for future use and best overall value.

BDW42 BDW46 BDW47

ELECTRICAL CHARACTERISTICS ($T_C = 25^\circ\text{C}$ unless otherwise noted)

Characteristic	Symbol	Min	Max	Unit	
OFF CHARACTERISTICS					
Collector Emitter Sustaining Voltage (1) ($I_C = 30\text{ mAdc}$, $I_B = 0$)	BDW46 BDW42/BDW47	$V_{CEO(sus)}$	80 100	— —	Vdc
Collector Cutoff Current ($V_{CE} = 40\text{ Vdc}$, $I_B = 0$) ($V_{CE} = 50\text{ Vdc}$, $I_B = 0$)	BDW46 BDW42/BDW47	I_{CEO}	— —	2.0 2.0	mAdc
Collector Cutoff Current ($V_{CB} = 80\text{ Vdc}$, $I_E = 0$) ($V_{CB} = 100\text{ Vdc}$, $I_E = 0$)	BDW41/BDW46 BDW42/BDW47	I_{CBO}	— —	1.0 1.0	mAdc
Emitter Cutoff Current ($V_{BE} = 5.0\text{ Vdc}$, $I_C = 0$)		I_{EBO}	—	2.0	mAdc
ON CHARACTERISTICS (1)					
DC Current Gain ($I_C = 5.0\text{ Adc}$, $V_{CE} = 4.0\text{ Vdc}$) ($I_C = 10\text{ Adc}$, $V_{CE} = 4.0\text{ Vdc}$)		h_{FE}	1000 250	— —	
Collector–Emitter Saturation Voltage ($I_C = 5.0\text{ Adc}$, $I_B = 10\text{ mAdc}$) ($I_C = 10\text{ Adc}$, $I_B = 50\text{ mAdc}$)		$V_{CE(sat)}$	— —	2.0 3.0	Vdc
Base–Emitter On Voltage ($I_C = 10\text{ Adc}$, $V_{CE} = 4.0\text{ Vdc}$)		$V_{BE(on)}$	—	3.0	Vdc
SECOND BREAKDOWN (2)					
Second Breakdown Collector Current with Base Forward Biased BDW42 BDW46/BDW47	$V_{CE} = 28.4\text{ Vdc}$ $V_{CE} = 40\text{ Vdc}$ $V_{CE} = 22.5\text{ Vdc}$ $V_{CE} = 36\text{ Vdc}$	$I_{S/b}$	3.0 1.2 3.8 1.2	— — — —	Adc
DYNAMIC CHARACTERISTICS					
Magnitude of common emitter small signal short circuit current transfer ratio ($I_C = 3.0\text{ Adc}$, $V_{CE} = 3.0\text{ Vdc}$, $f = 1.0\text{ MHz}$)		f_T	4.0	—	MHz
Output Capacitance ($V_{CB} = 10\text{ Vdc}$, $I_E = 0$, $f = 0.1\text{ MHz}$)	BDW42 BDW46/BDW47	C_{ob}	— —	200 300	pF
Small–Signal Current Gain ($I_C = 3.0\text{ Adc}$, $V_{CE} = 3.0\text{ Vdc}$, $f = 1.0\text{ kHz}$)		h_{fe}	300	—	

(1) Pulse Test: Pulse Width = 300 μs , Duty Cycle = 2.0%.

(2) Pulse Test non repetitive: Pulse Width = 250 ms.

BDW42 BDW46 BDW47

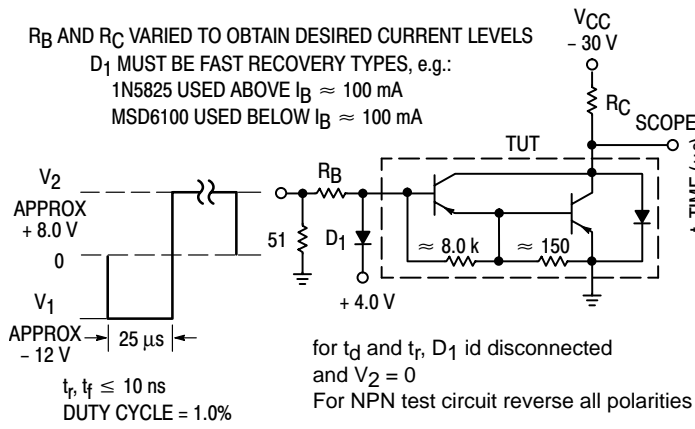

Figure 2. Switching Times Test Circuit

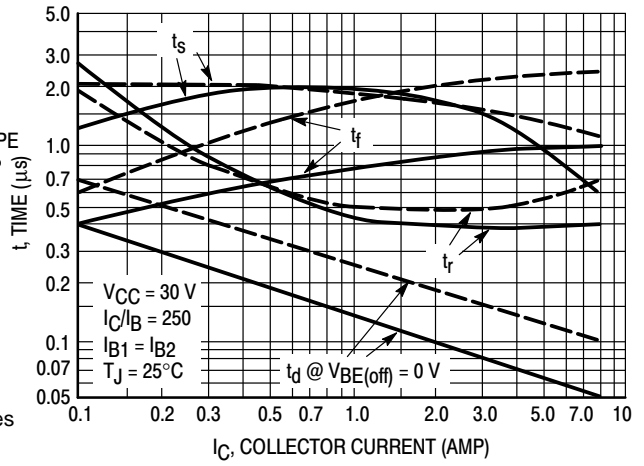

Figure 3. Switching Times

BDW42 BDW46 BDW47

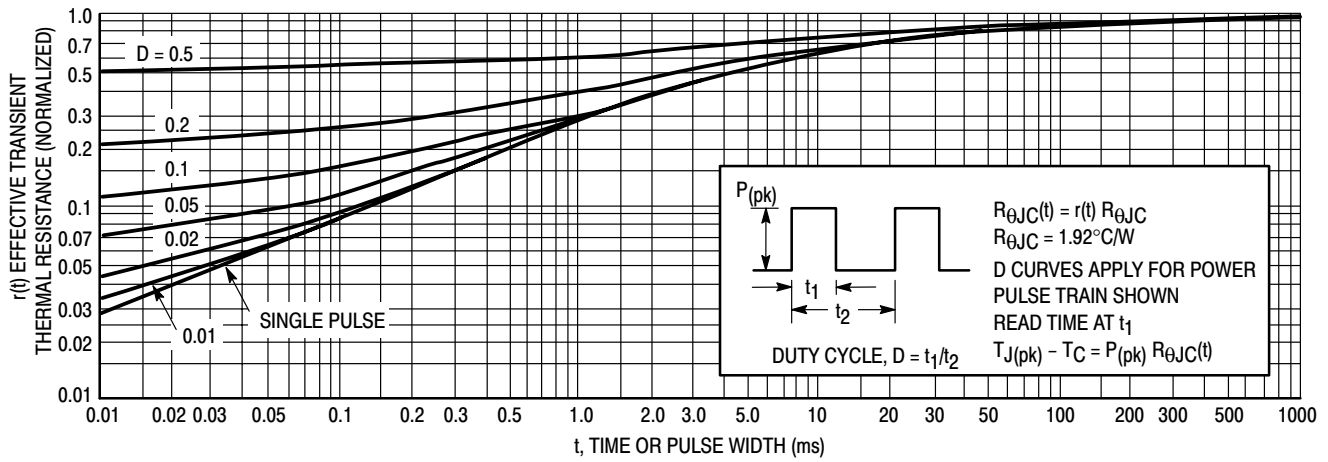

Figure 4. Thermal Response

ACTIVE-REGION SAFE OPERATING AREA

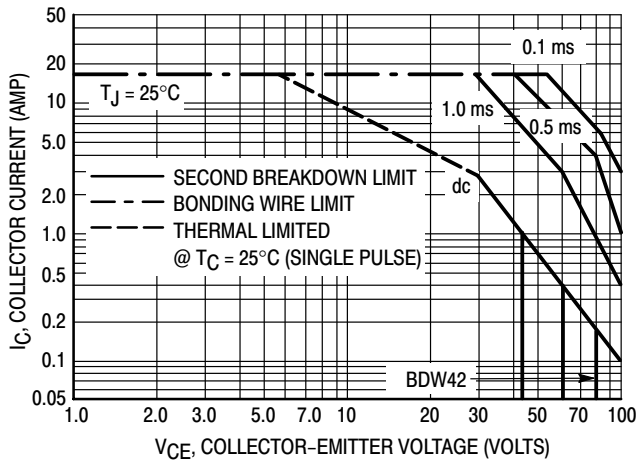

Figure 5. BDW42

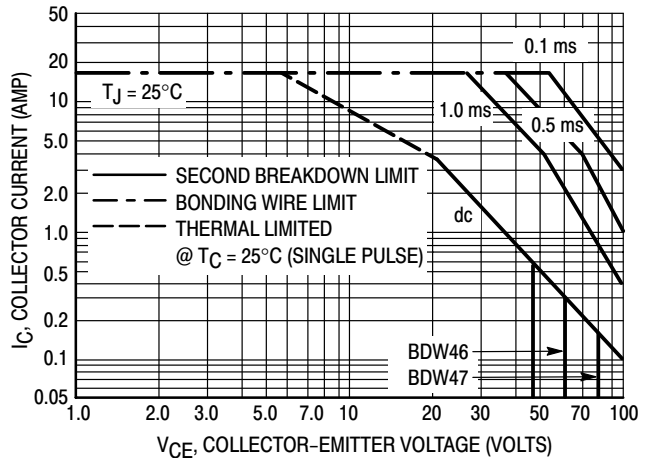

Figure 6. BDW46 and BDW47

There are two limitations on the power handling ability of a transistor: average junction temperature and second breakdown. Safe operating area curves indicate $I_C - V_{CE}$ limits of the transistor that must be observed for reliable operation; i.e., the transistor must not be subjected to greater dissipation than the curves indicate. The data of Figure 5 and 6 is based on $T_{J(pk)} = 200^\circ\text{C}$; T_C is variable depending on conditions.

Second breakdown pulse limits are valid for duty cycles to 10% provided $T_{J(pk)} \leq 200^\circ\text{C}$. $T_{J(pk)}$ may be calculated from the data in Figure 4. At high case temperatures, thermal limitations will reduce the power that can be handled to values less than the limitations imposed by second breakdown.

*Linear extrapolation

BDW42 BDW46 BDW47

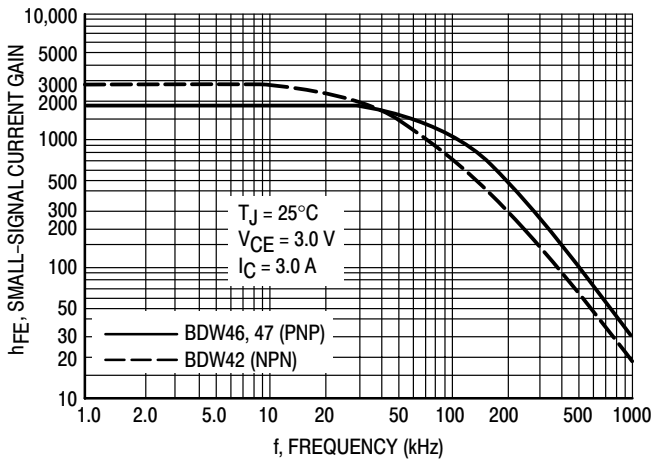

Figure 7. Small-Signal Current Gain

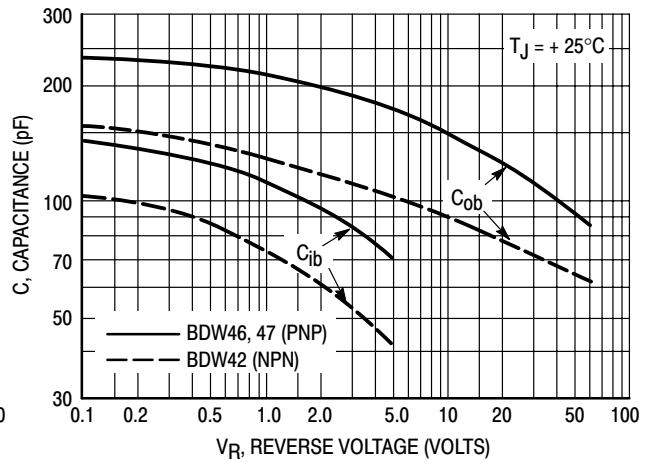
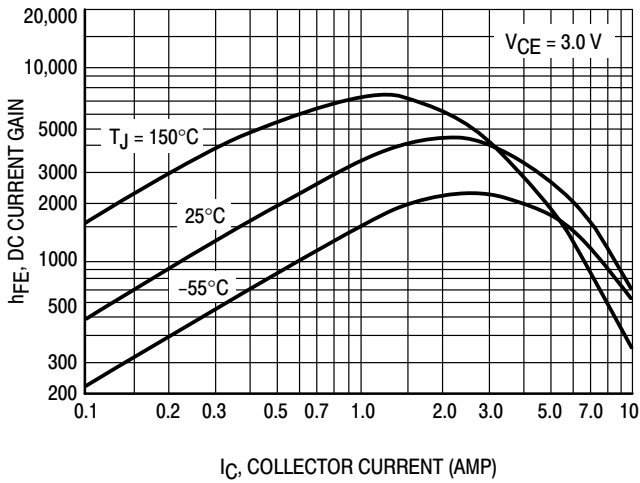

Figure 8. Capacitance

BDW40, 41, 42 (NPN)



BDW45, 46, 47 (PNP)

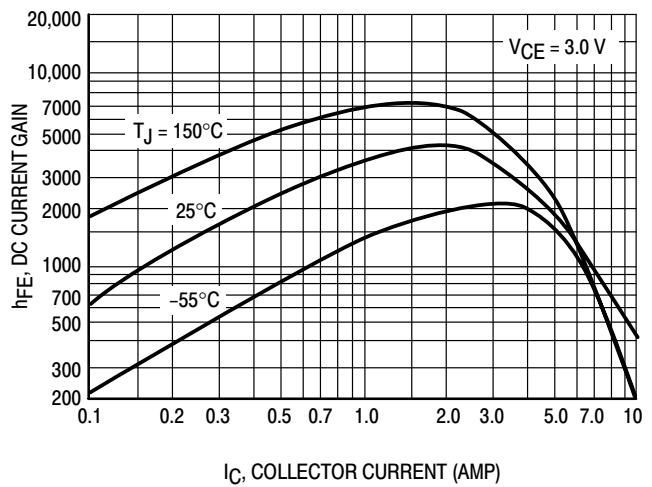

Figure 9. DC Current Gain

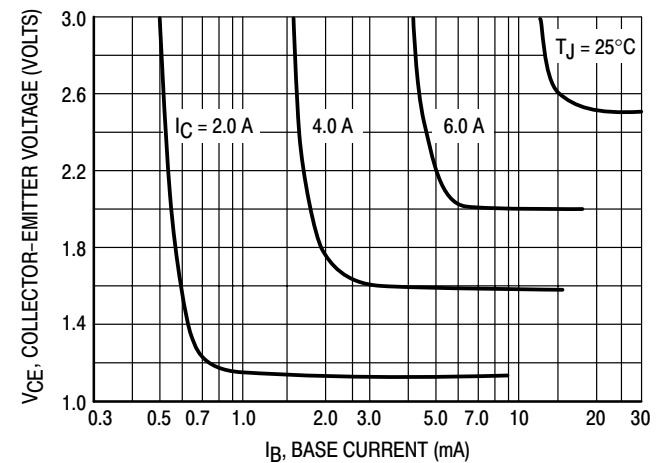
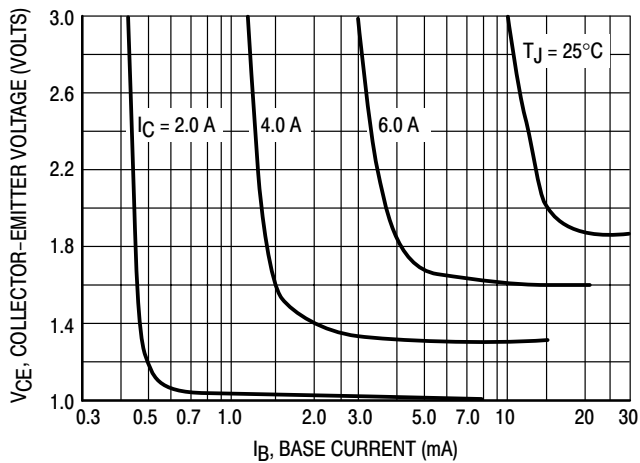
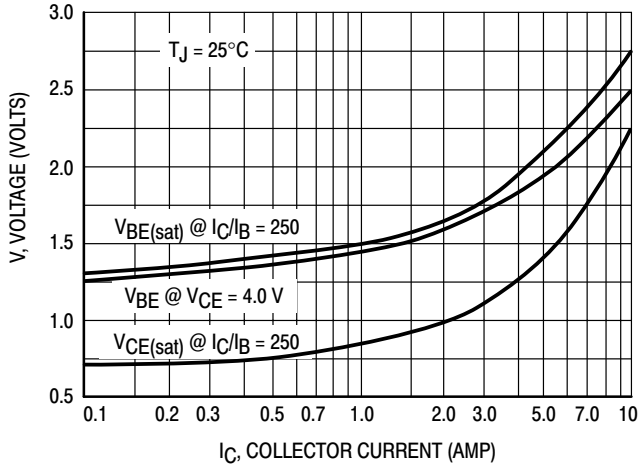

Figure 10. Collector Saturation Region

BDW42 BDW46 BDW47

BDW40, 41, 42 (NPN)



BDW45, 46, 47 (PNP)

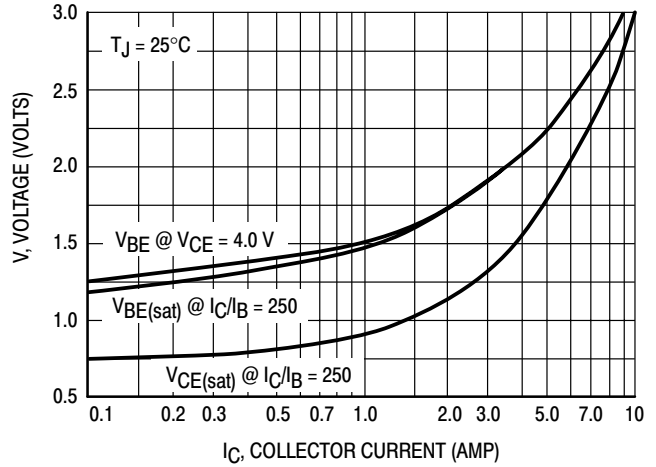

Figure 11. "On" Voltages

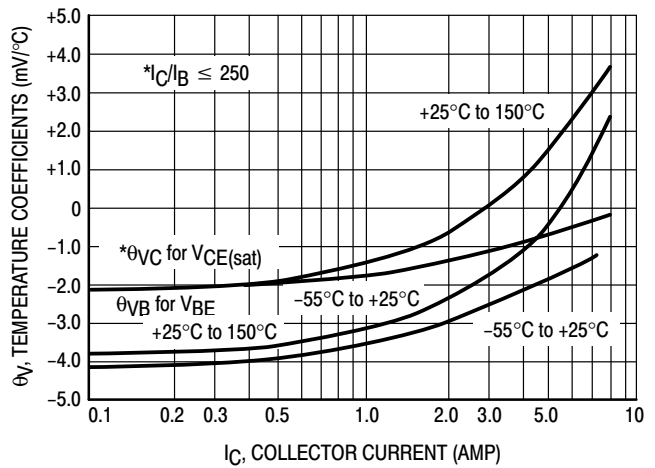
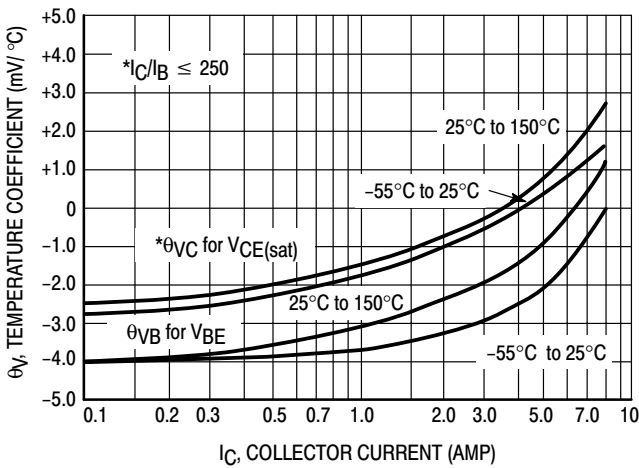

Figure 12. Temperature Coefficients

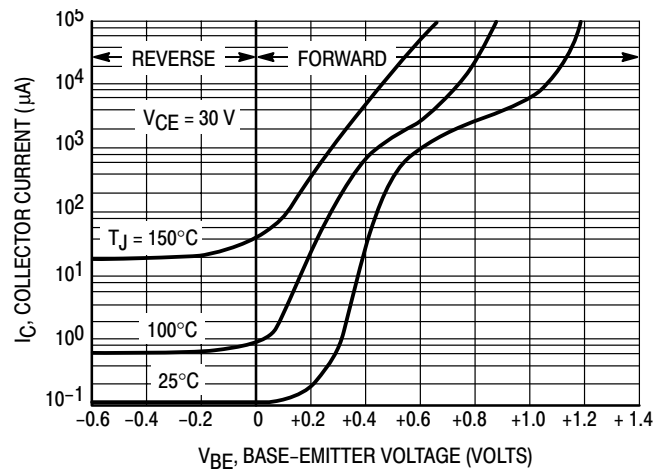
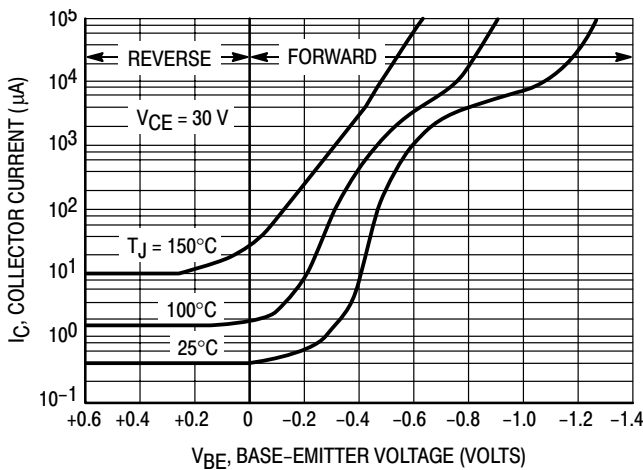

Figure 13. Collector Cut-Off Region

BDW42 BDW46 BDW47

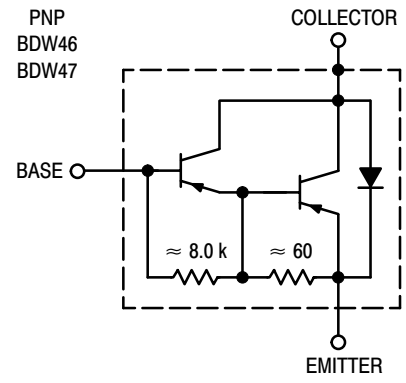
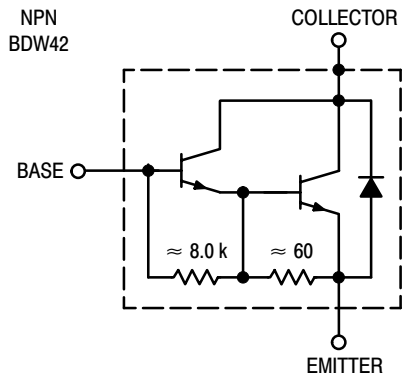
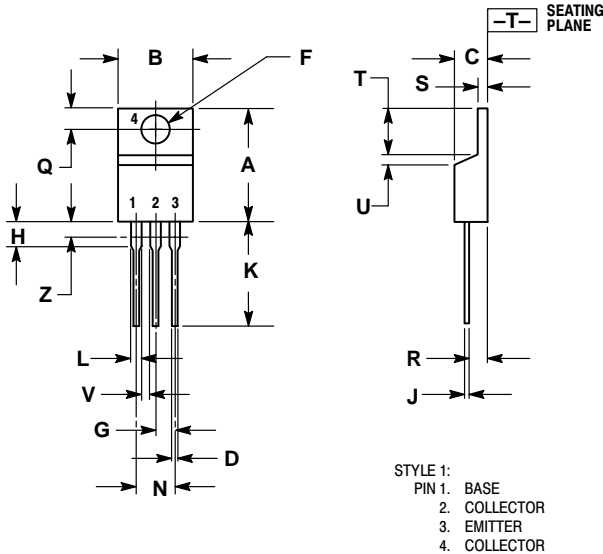

Figure 14. Darlington Schematic

BDW42 BDW46 BDW47

PACKAGE DIMENSIONS

TO-220AB CASE 221A-09 ISSUE AB



NOTES:

1. DIMENSIONING AND TOLERANCING PER ANSI Y14.5M, 1982.
2. CONTROLLING DIMENSION: INCH.
3. DIMENSION Z DEFINES A ZONE WHERE ALL BODY AND LEAD IRREGULARITIES ARE ALLOWED.

DIM	INCHES		MILLIMETERS	
	MIN	MAX	MIN	MAX
A	0.570	0.620	14.48	15.75
B	0.380	0.405	9.66	10.28
C	0.160	0.190	4.07	4.82
D	0.025	0.035	0.64	0.88
F	0.142	0.147	3.61	3.73
G	0.095	0.105	2.42	2.66
H	0.110	0.155	2.80	3.93
J	0.018	0.025	0.46	0.64
K	0.500	0.562	12.70	14.27
L	0.045	0.060	1.15	1.52
N	0.190	0.210	4.83	5.33
Q	0.100	0.120	2.54	3.04
R	0.080	0.110	2.04	2.79
S	0.045	0.055	1.15	1.39
T	0.235	0.255	5.97	6.47
U	0.000	0.050	0.00	1.27
V	0.045	----	1.15	----
Z	----	0.080	----	2.04

ON Semiconductor and  are registered trademarks of Semiconductor Components Industries, LLC (SCILLC). SCILLC reserves the right to make changes without further notice to any products herein. SCILLC makes no warranty, representation or guarantee regarding the suitability of its products for any particular purpose, nor does SCILLC assume any liability arising out of the application or use of any product or circuit, and specifically disclaims any and all liability, including without limitation special, consequential or incidental damages. "Typical" parameters which may be provided in SCILLC data sheets and/or specifications can and do vary in different applications and actual performance may vary over time. All operating parameters, including "Typicals" must be validated for each customer application by customer's technical experts. SCILLC does not convey any license under its patent rights nor the rights of others. SCILLC products are not designed, intended, or authorized for use as components in systems intended for surgical implant into the body, or other applications intended to support or sustain life, or for any other application in which the failure of the SCILLC product could create a situation where personal injury or death may occur. Should Buyer purchase or use SCILLC products for any such unintended or unauthorized application, Buyer shall indemnify and hold SCILLC and its officers, employees, subsidiaries, affiliates, and distributors harmless against all claims, costs, damages, and expenses, and reasonable attorney fees arising out of, directly or indirectly, any claim of personal injury or death associated with such unintended or unauthorized use, even if such claim alleges that SCILLC was negligent regarding the design or manufacture of the part. SCILLC is an Equal Opportunity/Affirmative Action Employer.

PUBLICATION ORDERING INFORMATION

Literature Fulfillment:

Literature Distribution Center for ON Semiconductor
P.O. Box 5163, Denver, Colorado 80217 USA
Phone: 303-675-2175 or 800-344-3860 Toll Free USA/Canada
Fax: 303-675-2176 or 800-344-3867 Toll Free USA/Canada
Email: ONlit@hibbertco.com

N. American Technical Support: 800-282-9855 Toll Free USA/Canada

JAPAN: ON Semiconductor, Japan Customer Focus Center
4-32-1 Nishi-Gotanda, Shinagawa-ku, Tokyo, Japan 141-0031
Phone: 81-3-5740-2700
Email: r14525@onsemi.com

ON Semiconductor Website: <http://onsemi.com>

For additional information, please contact your local Sales Representative.



LittleDiode supplies new, hard to find or obsolete electronic components and semiconductors all over the world.

With over two million different components listed you are sure to find the part you need.

Feel free to visit us today at our online store:

LittleDiode.com

Looking forward to providing you with the best possible service.