

5-channel Switching Regulator Controller BD9730KV

● Description

The BD9730KV is a 5-channel switching regulator controller IC designed for digital still cameras. This IC can be operated at 2.5V. (Min.). The 5-channel (4 channel for step-down and 1 channel for step-up) switching regulator controllers are integrated into a VQFP48 package. This IC can operate both external Bipolar and FET transistors. A triangle wave oscillator, a reference voltage, PWM comparator, a CMOS type driver, and a short protection circuit are all integrated in this single IC.

● Dimension (Unit : mm)

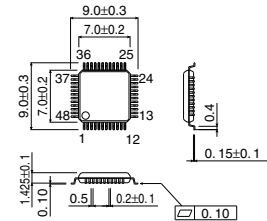

● Features

- 1) Operates at a supply voltage of 2.5V (Min.)
- 2) High-precision reference voltage of $1.0V \pm 1.2\%$
- 3) Can operate both external transistors of FET and Bipolar (Base current can be set by resistance.)
- 4) All channels have dead time control
- 5) Built-in output shutdown circuit (timer latch) when overloaded
- 6) Channels 1 and 5 can externally set the reference voltage
- 7) Channels 1, 4 and 5 can control independently the ON/OFF

VQFP48

● Applications

Digital still camera, portable DVD player, digital movie camera, PDA, W-CDMA

● Absolute Maximum Ratings (Ta=25°C)

Parameter	Symbol	Limits	Unit
Maximum applied voltage	Vmax	-0.3 ~ +12	V
Power dissipation	Pd	400 ^{*1}	mW
		900 ^{*2}	
Operating temperature range	Topr	-20 ~ +85	°C
Storage temperature range	Tstg	-55 ~ +125	°C

*1 When only IC is used. Derating : 4.0mW/°C for operation above Ta=25°C

*2 PCB (70mmx70mm, t=1.6mm) glass epoxy mounting.
Derating : 9.0mW/°C for operation above Ta=25°C

● Recommended Operating Conditions (Ta=25°C)

Parameter	Symbol	Min.	Typ.	Max.	Unit
Supply voltage ^{*3}	Vcc	2.5	—	11	V
Oscillating frequency	fosc	100	—	700	kHz
Output current	IOUT	—	—	30	mA

*3 REG output voltage is derated when Vcc is less than 2.6V-2.5V.

● Electrical characteristics (Unless otherwise noted; Ta=25°C, Vcc=6V, fosc=0.20MHz, STB1~5=3V)

Parameter	Symbol	Min.	Typ.	Max.	Unit	Conditions
Circuit current at standby	Ist	—	—	10	μA	STB1~5=0V
Circuit current at operating	Icc	—	4.8	9.5	mA	
(Reference voltage)						
Output voltage	Vref	0.988	1.0	1.012	V	Iref=-1mA
(Internal regulator)						
Output voltage REGA	VREGA	2.4	2.5	2.6	V	Ireg=-1mA
(Shutdown at overload)						
CH1~5 threshold voltage	Vsc1~5	0.90	1.0	1.10	V	VSCP1~5=1.5V~0.5V
(Protection circuit)						
SCP pin detection voltage	Vtsc	0.90	1.0	1.10	V	VSCP=0V~1.5V
Triangular oscillator						
Oscillating frequency	fosc1	0.179	0.200	0.221	MHz	RT=24kΩ, CT=220pF
(Output)						
Output voltage "H" at operating	VSATH	Vcc-0.4	Vcc-0.2	—	V	Io=10mA
Output voltage "L" at operating	VSATL	—	0.2	0.4	V	Io=-10mA
Maximum output source current	Iosource	30	—	—	mA	
Maximum output sink current	Iosink	—	—	-30	mA	
(STB1~5)						
STB pin control voltage	Operating	VSTBL	2.0	—	—	V
	Non-operating	VSTBH	-0.3	—	0.3	V

● Application Circuit

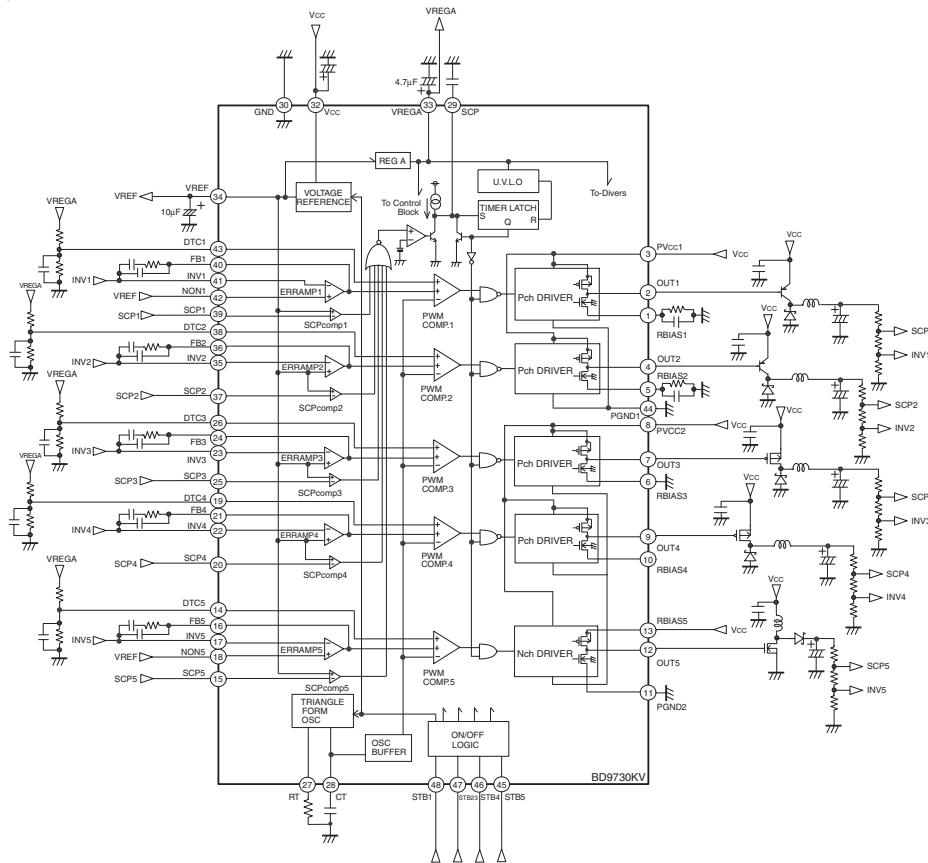



LittleDiode supplies new, hard to find or obsolete electronic components and semiconductors all over the world.

With over two million different components listed you are sure to find the part you need.

Feel free to visit us today at our online store:

LittleDiode.com

Looking forward to providing you with the best possible service.