

6CH Power Driver for CD-ROM, DVD-ROM

BD7902CFS

BD7902CFS is a 6-channel driver IC that integrates all drivers necessary for CD-ROM, and DVD-ROM systems into a single chip. The built-in 2-channel sled motor driver is used for the stepping motor. Low heat operation can be achieved by applying the PWM driving system for sled and spindle motor drivers.

●Applications

CD-ROM, DVD-ROM

●Features

- 1) 3channel BTL driver, 2channel PWM driver and 3phase motor driver.
 - ALL of the motor and actuator for CD-ROM, DVD-ROM etc.
- 2) These mode is able to be selected by the two control terminals.
 - ON/OFF of loading, and other 5channels, brake mode select of spindle driver and standby mode.
- 3) Built-in triangular-wave generator.
- 4) Package SSOP-A54 has large power dissipation.
- 5) Built in thermal-shut-down circuit.

〈 Spindle driver 〉

- Efficient drive by current feedback PWM drive.
- Built in current limit, hall bias, short brake, FG output and reverse protection circuit.
- Low ON-Resistor. (RON=0.95Ω)

〈 Sled motor driver 〉

- Efficient drive by current feedback PWM drive.
- Built in 2channel for stepping motor.

〈 Actuator driver, Loading driver 〉

- Linear BTL drive system.

Optical disc ICs

●Absolute maximum ratings (Ta=25°C)

Parameter	Symbol	Limits	Unit
POWER MOS power supply voltage	SPVM1,2,SLRNF1,2	15*1	V
Preblock/BTL powerblock power supply voltage	V _{cc} ,SLVDD,AVM	15	V
PWM control block power supply voltage	DV _{cc}	7	V
Power dissipation	P _d	2.6*2	W
Operating temperature range	Topr	-35~+85	°C
Storage temperature	Tstg	-55~+150	°C

*1 POWER MOS output terminals (9, 11, 18, 34-37pin) is contained.

*2 PCB (70mm×70mm×1.6mm glass epoxy) mounting.

Reduced by 20.8mW for each increase in Ta of 1°C over 25°C.

●Recommended operating conditions (Ta=25°C)

(Set the power supply voltage taking allowable dissipation into considering)

Parameter	Symbol	Min.	Typ.	Max.	Unit
POWER MOS Power supply voltage 1	SPVM1, 2	–	V _{cc} *3	–	V
POWER MOS Power supply voltage 2	SLRNF1, 2	–	SLVDD*3	–	V
Preblock Power supply voltage	SLVDD, V _{cc}	AVM	12	14	V
Power block Power supply voltage	AVM	4.3	5.0	V _{cc}	V
PWM control block Power supply voltage	DV _{cc}	4.3	5.0	6.0	V
Spindle output current	I _{osp}	–	1.2	2.5*4	A
SL/FO/TR/LO output current	I _{oo}	–	0.5	0.8	A

*3 Set the same supply voltage to V_{cc} and SPVM1, 2 to SLVDD and SLRNF1, 2.

*4 The current is guaranteed 3.0A in case of the current is turned on/off in a duty-ratio of less than 1/10 with a maximum on-time of 5msec.

Optical disc ICs

●Block diagram

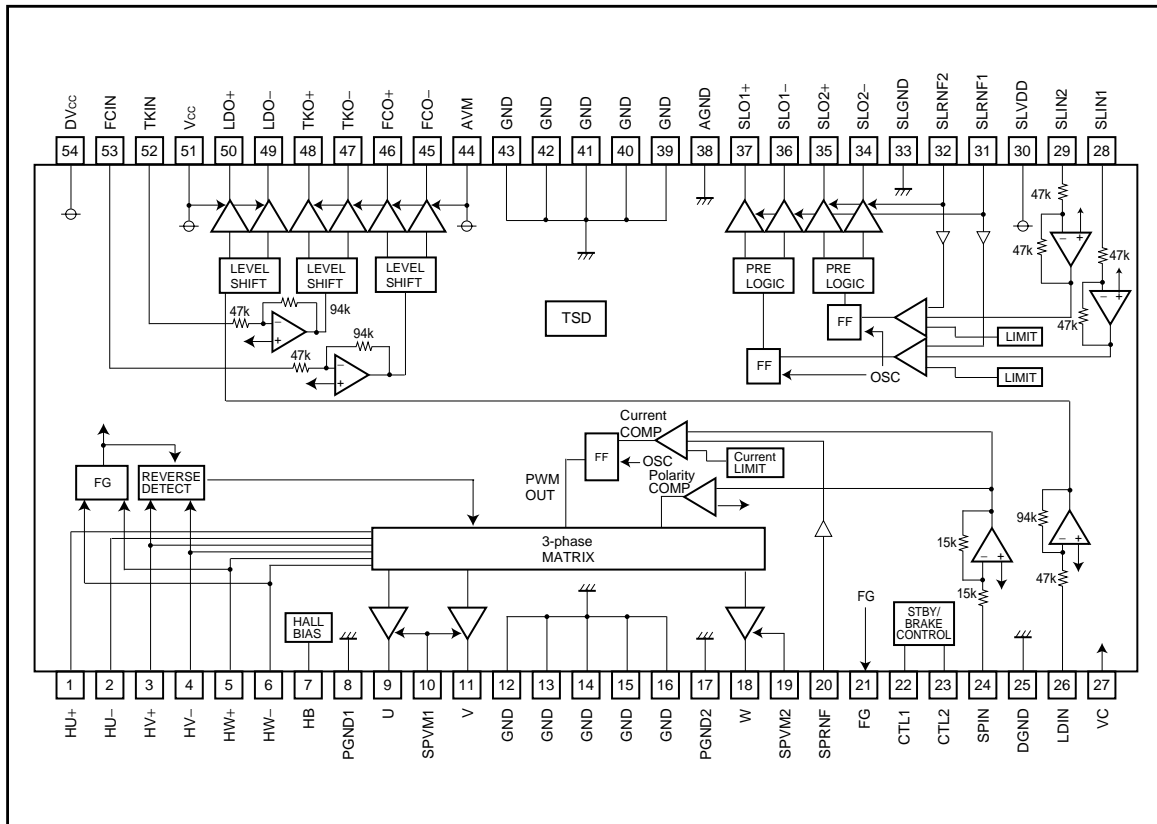

Optical disc ICs

●Pin descriptions

Pin No.	Pin name	Function	Pin No.	Pin name	Function
1	HU+	Hall amp. U positive input	28	SLIN1	Sled driver 1 input
2	HU-	Hall amp. U negative input	29	SLIN2	Sled driver 2 input
3	HV+	Hall amp. V positive input	30	SLVDD	Sled driver PowerMOS pre-supply
4	HV-	Hall amp. V negative input	31	SLRNF1	Sled driver 1 current sense
5	HW+	Hall amp. W positive input	32	SLRNF2	Sled driver 2 current sense
6	HW-	Hall amp. W negative input	33	SLGND	Sled driver power ground
7	HB	Hall bias	34	SLO2-	Sled driver 2 negative output
8	PGND1	Spindle driver power ground 1	35	SLO2+	Sled driver 2 positive output
9	U	Spindle driver output U	36	SLO1-	Sled driver 1 negative output
10	SPVM1	Spindle driver power supply 1	37	SLO1+	Sled driver 1 positive output
11	V	Spindle driver output V	38	AGND	Ground
12	GND	GND	39	GND	GND
13	GND	GND	40	GND	GND
14	GND	GND	41	GND	GND
15	GND	GND	42	GND	GND
16	GND	GND	43	GND	GND
17	PGND2	Spindle driver power ground 2	44	AVM	Actuator driver block power supply
18	W	Spindle driver output W	45	FCO-	Focus driver negative output
19	SPVM2	Spindle driver power supply 2	46	FCO+	Focus driver positive output
20	SPRNF	Spindle driver current sense	47	TKO-	Tracking driver negative output
21	FG	Frequency generator output	48	TKO+	Tracking driver positive output
22	CTL1	Driver logic control input 1	49	LDO-	Loading driver negative output
23	CTL2	Driver logic control input 2	50	LDO+	Loading driver positive output
24	SPIN	Spindle driver input	51	Vcc	BTL pre and Loading power supply
25	DGND	PWM block pre-ground	52	TKIN	Tracking driver input
26	LDIN	Loading driver input	53	FCIN	Focus driver input
27	VC	Reference voltage input	54	DVcc	PWM block control power supply

* Positive/negative of the output terminals are determined in reference to those of the input terminals.

Optical disc ICs

●Input output circuit

<p>Three-phase motor driver output</p>	<p>Spindle driver current detection input</p>	<p>Hall bias</p>
<p>Hall signal input</p>		<p>FG signal output</p>
<p>PWM driver output SLED1, 2</p>	<p>BTL driver output FO, TK</p>	<p>BTL driver output LD</p>
<p>BTL driver input FO, TK, LD</p>	<p>PWM driver input SLED1, 2</p>	<p>PWM driver input Spindle</p>
<p>Control signal reference voltage input</p>		<p>Control signal input</p>

Optical disc ICs

●Electrical characteristics

(unless otherwise noted, Ta=25°C, SLVDD=V_{CC}=12V, DV_{CC}=AVM=5V, VC=1.65V, SPRNF=0.33Ω, SLRNF=0.5Ω)

Parameter	Symbol	Min.	Typ.	Max.	Unit	Conditions	Circuit
Circuit current							
Quiescent current 1	IQ1	–	12	20	mA	V _{CC} (Loading OFF)	Fig1, 2
Quiescent current 2	IQ2	–	9	16	mA	V _{CC} (Loading ON)	Fig1, 2
Quiescent current 3	IQ3	–	2.7	4.9	mA	DV _{CC}	Fig1, 2
Standby-on current 1	IST1	–	0.09	0.2	mA	V _{CC}	Fig1, 2
Standby-on current 2	IST2	–	0	0.1	mA	DV _{CC}	Fig1, 2
Sled driver block							
Input dead zone (one side)	VDZSL	15	40	65	mV		Fig1, 2
Input output gain	gmSL	0.8 (0.4)	1.0 (0.5)	1.2 (0.6)	A/V (V/V)	SLRNF=0.5Ω	Fig1, 2
Output ON resistor (upper)	RONUSL	–	1.8	2.3	Ω	IL=500mA	Fig1, 2
Output ON resistor (lower)	RONLSL	–	0.85	1.5	Ω	IL=-500mA	Fig1, 2
Output limit current	ILIMSL	0.8 (0.4)	0.94 (0.47)	1.08 (0.54)	A (V)	SLRNF=0.5Ω	Fig1, 2
PWM frequency	fosc	–	100	–	kHz		Fig1, 2
Spindle driver block (Hall bias)							
Hall bias voltage	VHB	0.7	1.15	1.6	V	IHB=10mA	Fig1, 2
Spindle driver block (Hall amplifier)							
Input bias current	IHIB	–	1	5	μA		Fig1, 2
Minimum input level	VHIM	50	–	–	mV _{PP}		Fig1, 2
Common mode input Range	VHICM	1	–	4	V		Fig1, 2
Spindle driver block (Torque control)							
Input dead zone (one side)	VDZSP	20	50	90	mV		Fig1, 2
Input output gain	gmSP	2.4 (0.8)	3.0 (1.0)	3.6 (1.2)	A/V (V/V)	SPRNF=0.33Ω	Fig1, 2
Output ON resistor (upper)	RONUSP	–	0.6	1.0	Ω	IL=500mA	Fig1, 2
Output ON resistor (lower)	RONLSP	–	0.35	0.7	Ω	IL=-500mA	Fig1, 2
Output limit current	ILIMSP	1.2 (0.4)	1.42 (0.47)	1.64 (0.54)	A (V)	SPRNF=0.33Ω	Fig1, 2
PWM frequency	fosc	–	100	–	kHz		Fig1, 2
Spindle driver block (FG output)							
High voltage	VFGH	–	4.9	–	V	100kΩ pull up to DV _{CC}	Fig1, 2
Low voltage	VFGL	–	0.1	–	V		Fig1, 2
Actuator driver block							
Output offset voltage	VOFFT	-50	0	50	mV		Fig1, 2
Output saturation voltage "H"	VOHFT	–	0.45	0.8	V	IL=500mA	Fig1, 2
Output saturation voltage "L"	VOLFT	–	0.45	0.8	V	IL=-500mA	Fig1, 2
Voltage gain	GVFT	16.0	17.5	19.0	dB		Fig1, 2

© This product is not designed for protection against radioactive rays.

Optical disc ICs

Parameter	Symbol	Min.	Typ.	Max.	Unit	Conditions	Circuit
Loading driver block							
Output offset voltage	VOFLD	-50	0	50	mV		Fig1, 2
Output saturation voltage "H"	VOHLD	-	1.1	1.4	V	IL=500mA	Fig1, 2
Output saturation voltage "L"	VOLL	-	0.45	0.8	V	IL=-500mA	Fig1, 2
Voltage gain	GVLD	16.0	17.5	19.0	dB		Fig1, 2
CTL1, CTL2							
Input high voltage	VIH	2.0	-	-	V		Fig1, 2
Input low voltage	VIL	-	-	0.5	V		Fig1, 2
Others							
VC drop-muting	VMVC	0.4	0.7	1.0	V		Fig1, 2
Vcc drop-muting	VMVcc	3.4	3.8	4.2	V		Fig1, 2

© This product is not designed for protection against radioactive rays.

Optical disc ICs

● Measurement circuits

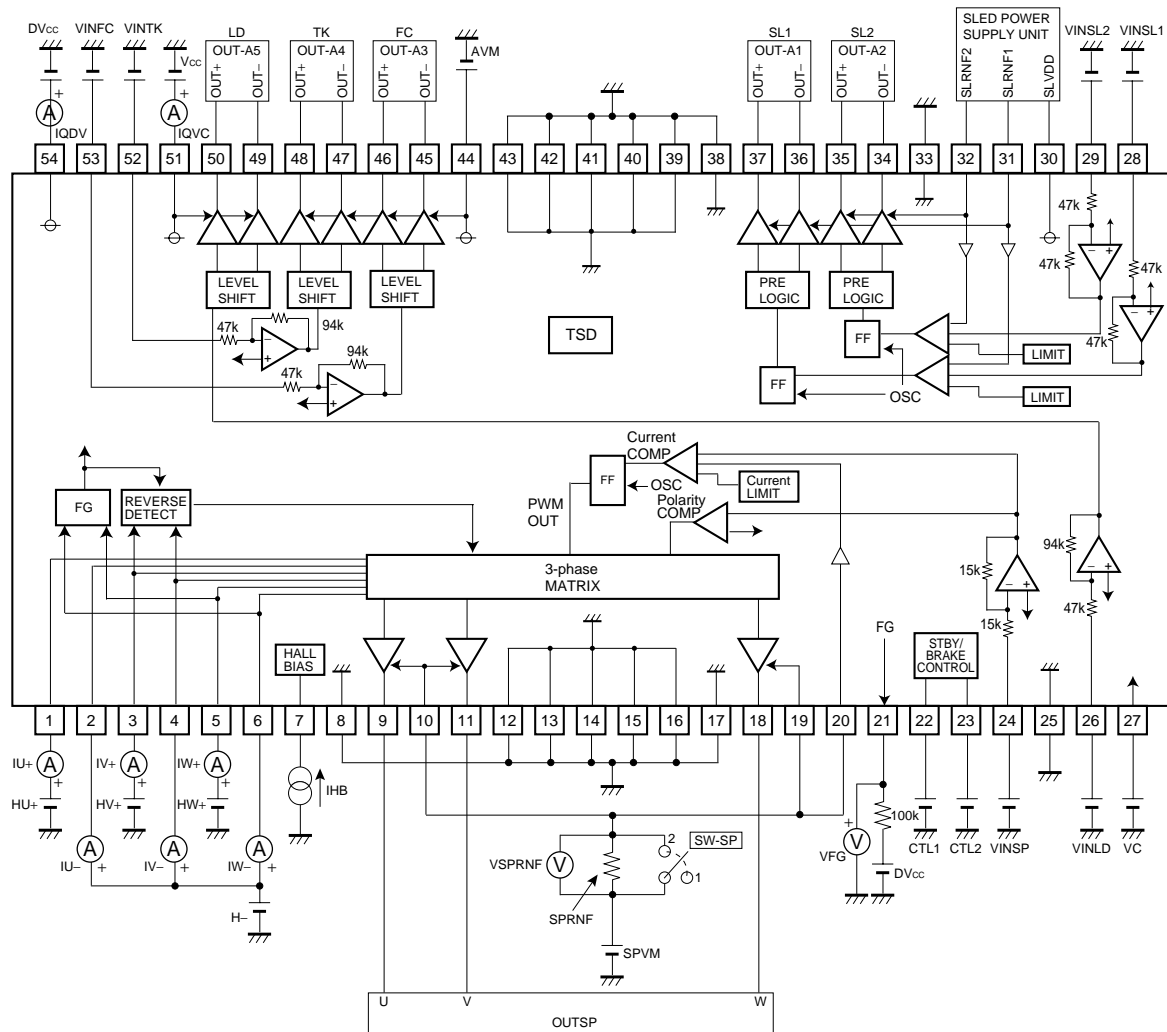
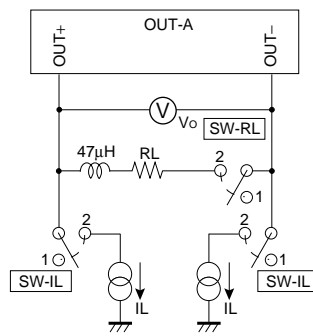
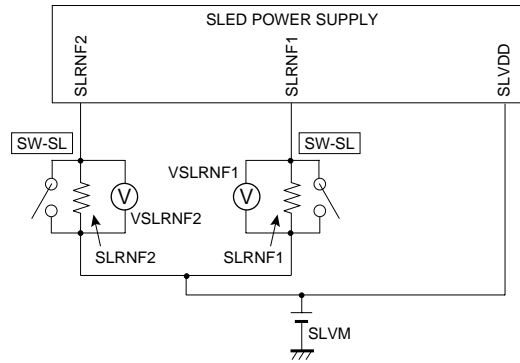

Fig.1



*A3, A4 and A5 require no coil. (47µH)

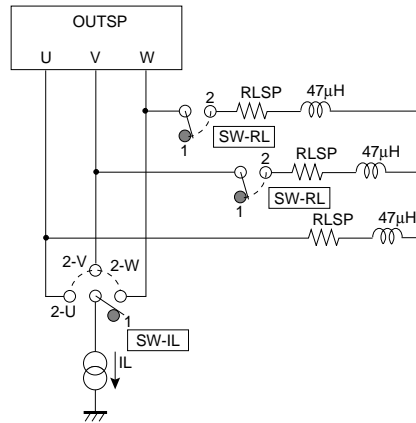

Fig.2

Optical disc ICs

●Table of measure circuit switches position 1

(V_{CC}=SPVM=SLVM=12V, DV_{CC}=AVM=5V, VC=1.65V, RL (act) =8Ω, RL (SL) =8Ω+47μH, RL (SP) =2Ω+47μH, SLRNF=0.5Ω, SPRNF=0.33Ω, H₋=2.5V, HU₊=2.6V, HV₊=HW₊=2.4V)

Designation	INPUT	CTL		SWITCH				Conditions	Measure point
	VIN	1	2	RL	SP	SL	IL		
Circuit current									
IQ1	-	L	H	1	1	1	1		IQVC
IQ2	-	H	L	1	1	1	1		IQVC
IQ3	-	L	H	1	1	1	1		IQDV
IST1	-	L	L	1	1	1	1		IQVC
IST2	-	L	L	1	1	1	1		IQDV
Sled driver block									
VDZSL	*1	H	H	2	1	1	1	*1 Check VSLRNF with no output at VIN=VC±15mV Check VSLRNF with output at VIN=VC±65mV	VSLRNF
gmSL	*2	H	H	2	1	1	1	See bellow	VSLRNF
RONUSL	3.3V (0V)	H	H	1	1	2	2	ILSL=500mA RON= $\frac{12V - VOSL + (-)}{0.5A}$	OUT+ (-)
RONLSL	0V (3.3V)	H	H	1	1	2	2	ILSL=-500mA RON= $\frac{VOSL + (-)}{0.5A}$	OUT+ (-)
ILIMSL	3.3V (0V)	H	H	2	1	1	1		VSLRNF
fosc	1.45	H	H	2	1	1	1		VOSL+

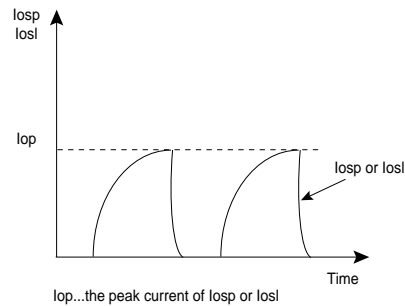
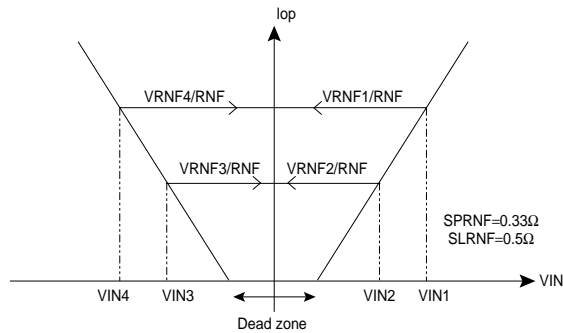

*2 Sled driver

VIN1=240mV, VIN2=140mV
VIN3=-140mV, VIN=-240mV

$$gm (+) = \left(\frac{VSLRNF1 - VSLRNF2}{240mV - 140mV} \right) / 0.5\Omega$$

$$gm (-) = \left(\frac{VSLRNF4 - VSLRNF3}{240mV - 140mV} \right) / 0.5\Omega$$

*4 Spindle driver

VIN1=150mV, VIN2=100mV
VIN3=-100mV, VIN=-150mV

$$gm (+) = \left(\frac{VSPRNF1 - VSPRNF2}{150mV - 100mV} \right) / 0.33\Omega$$

$$gm (-) = \left(\frac{VSPRNF4 - VSPRNF3}{150mV - 100mV} \right) / 0.33\Omega$$

Optical disc ICs

●Table of measure circuit switches position 2

(V_{CC}=SPVM=SLVM=12V, DV_{CC}=AVM=5V, VC=1.65V, RL (act) =8Ω, RL (SL) =8Ω+47μH, RL (SP) =2Ω+47μH, SLRNF=0.5Ω, SPRNF=0.33Ω, H₋=2.5V, HU₊=2.6V, HV₊=HW₊=2.4V)

Designation	INPUT	CTL		SWITCH				Conditions	Measure point
	VIN	1	2	RL	SP	SL	IL		
Spindle driver block									
〈 Hall bias 〉									
VHB	1.65V	H	H	1	1	1	1	IHB=10mA	Pin 7
〈 Hall amplifier 〉									
IHIB	1.65V	H	H	1	1	1	1	Current flowing in each terminal at H ₋ =2.5V, HW ₊ =2.7V (2.3V), HV=2.5V	IU ₊ (-), IV ₊ (-), IW ₊ (-)
〈 Torque command 〉									
VDZSP	*3	L	H	2	1	1	1	*2 Check VRNF with no output at VIN=VC±20mV Check VRNF with output at VIN=VC±90mV	VSPRNF
gmSP	*4	L	H	2	1	1	1	See 15 of 20	VSPRNF
RONUSP	3.3V	H	H	1	2	1	2	ILSP=500mA $RON = \frac{12V - VOSP}{0.5A}$	OUTU, V, W
RONLSP	3.3V	H	H	1	2	1	2	ILSP=-500mA $RON = \frac{VOSP}{0.5A}$	OUTU, V, W
ILIMSP	3.3V	H	H	2	1	1	1		VSPRNF
fosc	1.85	H	H	2	1	1	1		VOSPU
〈 FG 〉									
VFGH	1.65V	H	H	1	1	1	1	HW ₊ =2.4V	VFG
VFGL	1.65V	H	H	1	1	1	1	HW ₊ =2.6V	VFG

*5 Condition of input

HU ₊	HV ₊	HW ₊	U	V	W	Condition	Measure point
2.4V	2.6V	2.6V	Source	Hi-Z	Sink	IOSPU=500mA	VOSPU
2.6V	2.4V	2.6V	Sink	Source	Hi-Z	IOSPV=500mA	VOSPV
2.6V	2.6V	2.4V	Hi-Z	Sink	Source	IOSPW=500mA	VOSPW
2.6V	2.4V	2.4V	Sink	Hi-Z	Source	IOSPU=-500mA	VOSPU
2.4V	2.6V	2.4V	Source	Sink	Hi-Z	IOSPV=-500mA	VOSPV
2.4V	2.4V	2.6V	Hi-Z	Source	Sink	IOSPW=-500mA	VOSPW

Optical disc ICs

●Table of measure circuit switches position 3

(V_{CC}=SPVM=SLVM=12V, DV_{CC}=AVM=5V, VC=1.65V, RL (act) =8Ω, RL (SL) =8Ω+47μH, RL (SP) =2Ω+47μH, SLRNF=0.5Ω, SPRNF=0.33Ω, H₋=2.5V, HU₊=2.6V, HV₊=HW₊=2.4V)

Designation	INPUT	CTL		SWITCH				Conditions	Measure point
	VIN	1	2	RL	SP	SL	IL		
Actuator driver block									
VOFFT	1.65V	H	H	2	1	1	1		VO
VOHFT	3.3V (0V)	H	H	1	1	1	2	IL=500mA	5-OUT+ (-)
VOLFT	0V (3.3V)	H	H	1	1	1	2	IL=-500mA	OUT+ (-)
GVFT	±0.25V	H	H	2	1	1	1	20log (VO - VOFFT) / ±0.25	VO
Loading driver block									
VOFLD	1.65V	H	L	2	1	1	1		VO
VOHLD	3.3V (0V)	H	L	1	1	1	2	IL=500mA	12-OUT+ (-)
VOLL	0V (3.3V)	H	L	1	1	1	2	IL=-500mA	OUT+ (-)
GVLD	±0.25V	H	L	2	1	1	1	20log (VO - VOFFT) / ±0.25	VO
CTL1, CTL2									
VIH	1.65V	L	L	2	1	1	1	Check active at "H"=2.0	IQVC
VIL	1.65V	H	H	2	1	1	1	Check stand-by at "L"=0.5	IQVC
CTL1, CTL2									
VMVC	1.65V	H	H	1	1	1	1	Check all output at VC=0.7V	OUTPUT
VMV _{CC}	1.65V	H	H	1	1	1	1	Check all output at V _{CC} =3.8V	OUTPUT

●Circuit operation

1. Driver control terminal 1 and 2 (pin22 and pin23)

All the drivers and spindle-drive braking mode can be switched on/off by inputting combinations of H-level signal (higher than 2V) and L-level signal (lower than 0.5V) to these terminals.

CTL1 (Pin22)	CTL2 (Pin23)	Spindle	Sled	Focus	Tracking	Loading	
L	L	×	×	×	×	×	1)
H	L	×	×	×	×	○	2)
-	H	○	○	○	○	×	○... ON ×... OFF

CTL1 (Pin22)	CTL2 (Pin23)	SPIN > VC	SPIN < VC	
L	H	Forward-rotation mode	Reverse-rotation braking mode	3)
H	H	Forward-rotation mode	Short-circuit braking mode	4)

1) Standby mode

The IC is brought into standby state, and its power dissipation can be limited.

2) Drivers muting

All the output channels except the loading are muted and their outputs are turn off.

Optical disc ICs

3) Reverse-rotation braking mode (spindle)

A reverse-rotation torque is applied when $SPIN < VC$.

Reverse-rotation is detected with SPIN input and Hall input. If the spindle detects reverse rotation when $SPIN < VC$, all the outputs are shorted out to GND.

4) Short-circuit braking mode (spindle)

All the spindle driver outputs are shorted out to GND when $SPIN < VC$.

2. Input/output timing chart

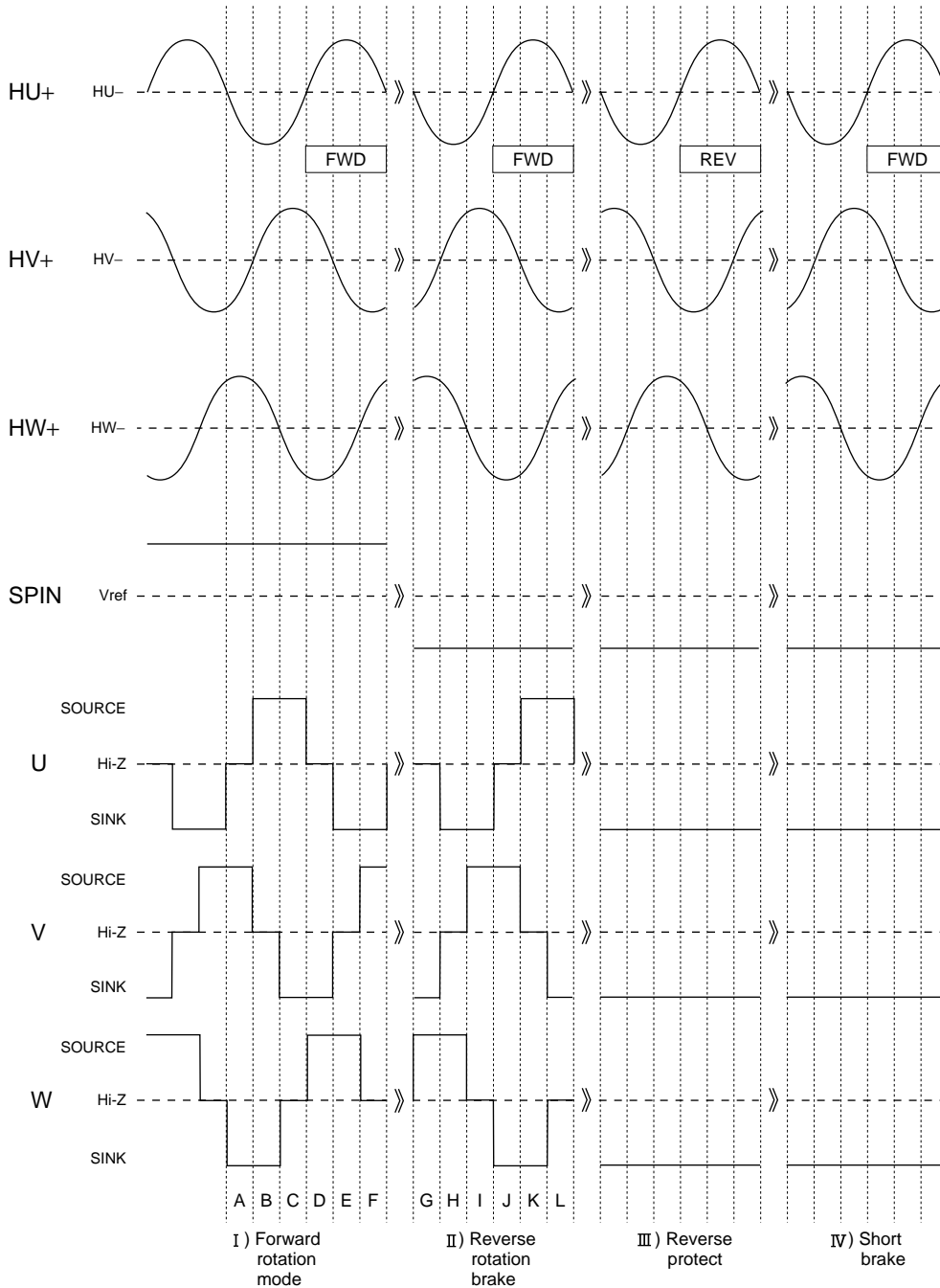

Optical disc ICs

I) Forward-rotation mode

In this mode, the disc rotation is started and accelerated.

When forward-rotation signal inputs from the Hall elements to the positive spindle-drive input terminals (SPIN > VC), the spindle-drive output terminals output forward torque signal.

	Hall amplifier input (forward rotation)						SPIN > VC		
	HU+	HU-	HV+	HV-	HW+	HW-	U	V	W
A	L	H	L	H	H	L	Hi-Z	Source	Sink
B	L	H	H	L	H	L	Source	Hi-Z	Sink
C	L	H	H	L	L	H	Source	Sink	Hi-Z
D	H	L	H	L	L	H	Hi-Z	Sink	Source
E	H	L	L	H	L	H	Sink	Hi-Z	Source
F	H	L	L	H	H	L	Sink	Source	Hi-Z

Source=PWM

II, III) Braking mode

In this mode, the disc rotation is decelerated and stopped.

< Reverse-rotation braking >

When the forward-rotation signal inputs from the Hall elements to the negative spindle-drive input terminals (SPIN < VC), the spindle-drive output terminals output reverse torque signal.

	Hall amplifier input (forward rotation)						SPIN < VC		
	HU+	HU-	HV+	HV-	HW+	HW-	U	V	W
G	L	H	L	H	H	L	Hi-Z	Sink	Source
H	L	H	H	L	H	L	Sink	Hi-Z	Source
I	L	H	H	L	L	H	Sink	Source	Hi-Z
J	H	L	H	L	L	H	Hi-Z	Source	Sink
K	H	L	L	H	L	H	Source	Hi-Z	Sink
L	H	L	L	H	H	L	Source	Sink	Hi-Z

Source=PWM

3. Hall inputs (pin 1 to 6) and Hall bias (pin 7) (Spindle)

Hall elements can be connected either in series or in parallel. Set the Hall input voltage to 1.0 to 4.0V.

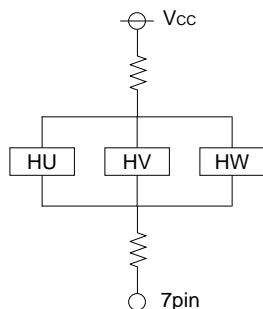

< Parallel connection >

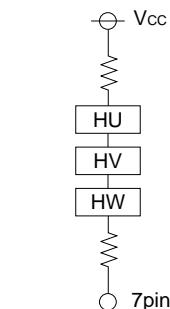

< Series connection >

Optical disc ICs

4. Torque command (spindle: pin 24, sled motor: pin 28 and 29) / output current detection terminals (spindle: pin 20, sled motor: pin 31 and 32)

The relation between the torque command input and the output current detection terminals input is expressed as shown below:

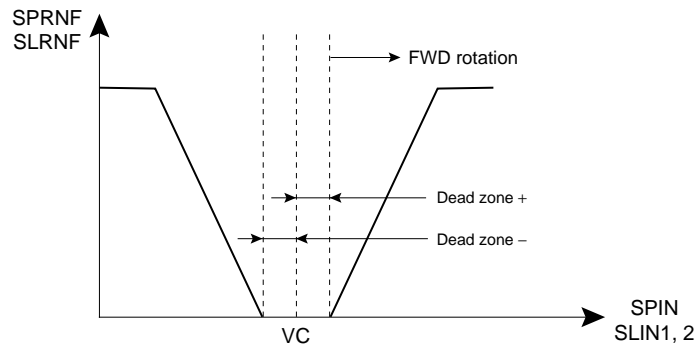

The input-output gain (g_m) and the output-limit current (I_{lim}) depend on the resistance of RNF (output current detection resistor). Please refer to the following expression.

The gain to drive the spindle or the sled motor can be decreased by connecting a resistor in series to each input terminal.

● Gain expression

	Spindle	Sled
Input-output gain g_m (A/V)	$1.0/RNF$	$0.5/RNF$
Output-limit current I_{lim} (A)	$0.47/RNF$	$0.47/RNF$
Gain with the added resistor g_m (A/V)	$15k/\{SPRNF \times (Rin + 15k)\}$	$0.5 \times 47k/\{SLRNF \times (Rin + 47k)\}$

Rin : added series resistor

5. PWM oscillation frequency

The PWM oscillation for driving the spindle and sled is free running. The oscillating frequency is 100kHz (typ.).

6. Muting functions

- a) VC-drop muting

When the voltage at VC terminal (pin 27) drops to a value lower than 0.7V (typ.), the outputs of all the channels are turned off. Set the VC terminal voltage to larger than 1.0V.

- b) V_{CC} -drop muting

When the voltages at DV_{CC} terminal (pin 54) and V_{CC} terminal (pin 51) drop to lower than 3.8V (typ.), the outputs of all the channels are turned off.

- c) Over voltage protection circuit

When the voltages at V_{CC} terminal (pin 51) drop to upper than 15.5V (typ.), the output of only the spindle block is turned off.

7. Thermal-shutdown

A thermal-shutdown circuit (over-temperature protection circuit) is built in to prevent the IC from thermal breakdown. Use the IC under the thermal loss allowed to the package. In case the IC is left running over the allowable loss, the junction temperature rises, and the thermal-shutdown circuit works at the junction temperature of 175°C (typ.) (the outputs of all the channels are turned off). When the junction temperature drops to 150°C (typ.), the IC start operating again.

Optical disc ICs

●Application example

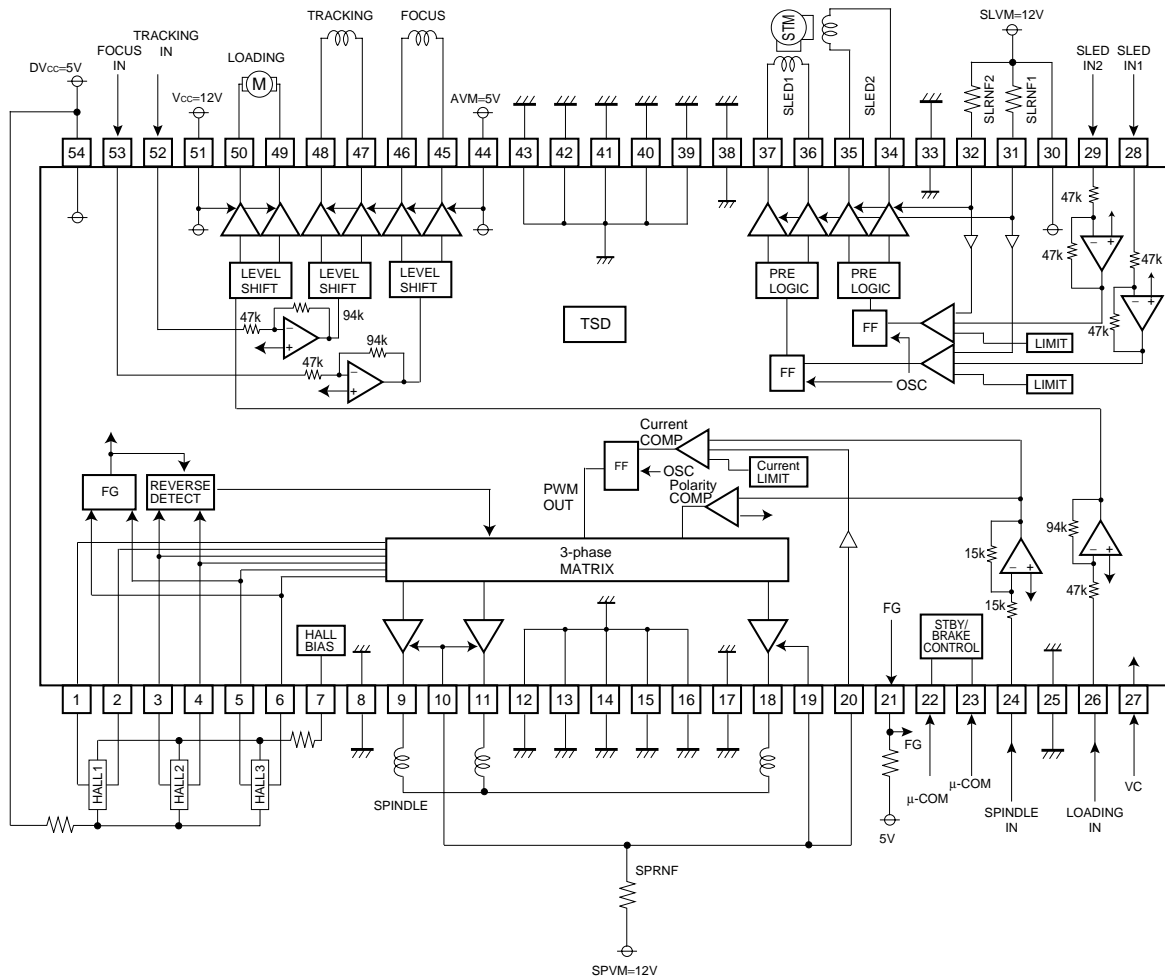

Fig.3

●Operation notes

(1) Wiring for SPRNF and SLRNF

Considering the wiring resistance, connect each detecting resistor as close as possible to the current detection terminals for the spindle drive SPRNF (pin 20) and the sled motor drive SLRNF 1 and 2 (pin 31 and 32) of the IC.

(2) Current detection reference voltage

The detection of current in the spindle and sled involves the detection of voltage between the detection resistances, but as the reference voltage of internal circuit, the voltage applied to V_{CC} (pin 51) is used by the spindle and that applied to $SLVDD$ (pin 30) by the sled.

For this reason, be sure to apply V_{CC} (pin 51) to the spindle and $SLVDD$ (pin 30) to the sled according to the corresponding power supply voltages to prevent voltage differences.

Optical disc ICs

(3) Reverse-rotation braking

In the case of reverse-rotation braking from high speed rotation, pay good attention to reverse electromotive force. Furthermore, fully check the voltage to be applied to the output terminal and consider the revolutions applied to the reverse-rotation brake.

(4) Bypass capacitor

Please connect a bypass capacitor (0.1μF) across the supply voltage lines close to the IC pins.

(5) Supply fault, ground fault, and short-circuit between output terminals

Do not short-circuit between any output pin and supply pin (supply fault) or ground (ground fault), or between any output pins (load short-circuit). When mounting the IC on the circuit board, be extremely cautious about the orientation of the IC. If the orientation is mistaken, the IC may break down, and produce smoke in some cases.

●Electrical characteristic curves

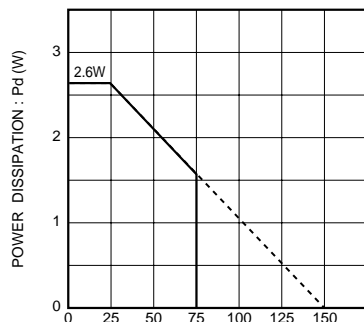

AMBIENT TEMPERATURE : Ta (°C)
 * On less than 25.7% (percentage occupied by copper foil),
 70×70mm², t=1.6mm glass epoxy mounting.

Fig.4 Power dissipation

●External dimensions (Units : mm)

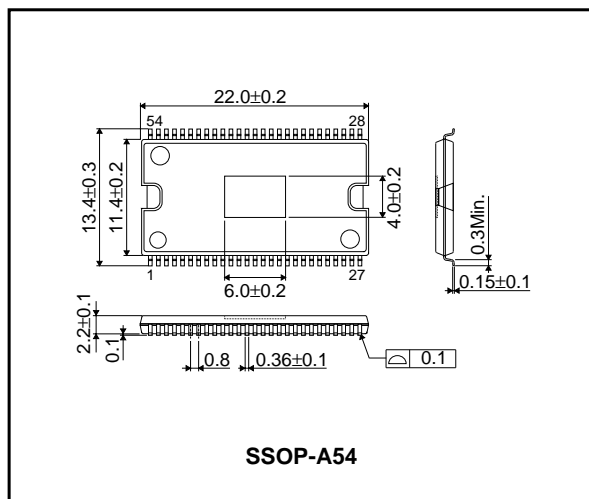



LittleDiode supplies new, hard to find or obsolete electronic components and semiconductors all over the world.

With over two million different components listed you are sure to find the part you need.

Feel free to visit us today at our online store:

LittleDiode.com

Looking forward to providing you with the best possible service.