

# Plastic Darlington Complementary Silicon Power Transistors

... designed for general purpose amplifier and high-speed switching applications.

- High DC Current Gain  
 $h_{FE} = 1400$  (Typ) @  $I_C$   
 $= 2.0$  Adc
- Collector–Emitter Sustaining Voltage — @ 10 mAdc  
 $V_{CEO(sus)} = 45$  Vdc (Min) — BD776  
 $= 60$  Vdc (Min) — BD777, 778  
 $= 80$  Vdc (Min) — BD780
- Reverse Voltage Protection Diode
- Monolithic Construction with Built–in Base–Emitter output Resistor

## MAXIMUM RATINGS

Rating	Symbol	BD776	BD777 BD778	BD780	Unit
Collector–Emitter Voltage	$V_{CEO}$	45	60	80	Vdc
Collector–Base Voltage	$V_{CB}$	45	60	80	Vdc
Emitter–Base Voltage	$V_{EB}$	5.0			Vdc
Collector Current — Continuous Peak	$I_C$	4.0 6.0			Adc
Base Current	$I_B$	100			mAdc
Total Device Dissipation $T_C = 25^\circ\text{C}$ – Derate above $25^\circ\text{C}$	$P_D$	15 0.12			Watts W/ $^\circ\text{C}$
Operating and Storage Junction Temperature Range	$T_J, T_{stg}$	–65 to +150			$^\circ\text{C}$

## THERMAL CHARACTERISTICS

Characteristics	Symbol	Max	Unit
Thermal Resistance, Junction to Case	$R_{\theta JC}$	8.34	$^\circ\text{C}/\text{W}$
Thermal Resistance, Junction to Ambient	$R_{\theta JA}$	83.3	$^\circ\text{C}/\text{W}$

**NPN  
BD777  
PNP  
BD776**

**BD778**

**BD780\***

\*ON Semiconductor Preferred Device

**DARLINGTON  
4-AMPERE  
COMPLEMENTARY  
SILICON  
POWER TRANSISTORS  
45, 60, 80 VOLTS  
15 WATTS**

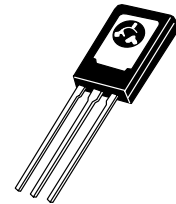

**CASE 77–08  
TO–225AA TYPE**

Preferred devices are ON Semiconductor recommended choices for future use and best overall value.

# BD777 BD776 BD778 BD780

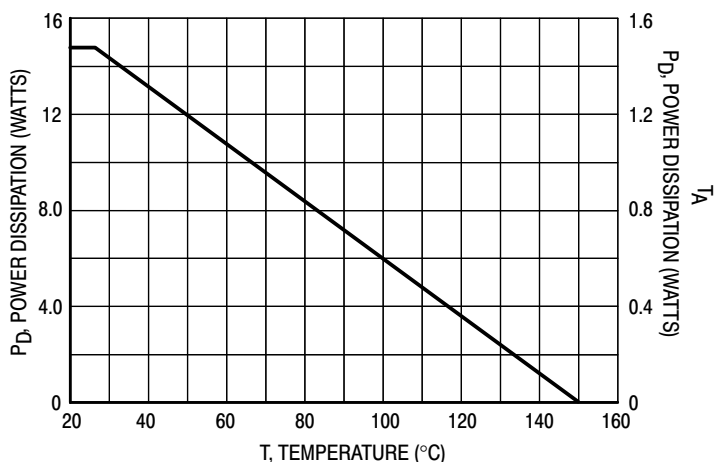

**Figure 1. Power Derating**

**ELECTRICAL CHARACTERISTICS** ( $T_C = 25^\circ\text{C}$  unless otherwise noted)

Characteristic	Symbol	Min	Max	Unit	
<b>OFF CHARACTERISTICS</b>					
Collector–Emitter Sustaining Voltage (1) ( $I_C = 10\text{ mAdc}$ , $I_B = 0$ )	BD776 BD777, BD778 BD780	$V_{CEO(sus)}$	45 60 80	— — —	Vdc
Collector Cutoff Current ( $V_{CE} = 20\text{ Vdc}$ , $I_B = 0$ ) ( $V_{CE} = 30\text{ Vdc}$ , $I_B = 0$ ) ( $V_{CE} = 40\text{ Vdc}$ , $I_B = 0$ )	BD776 BD777, BD778 BD780	$I_{CEO}$	— — —	100 100 100	$\mu\text{A dc}$
Collector Cutoff Current ( $V_{CB} = \text{Rated}$ , $V_{CEO(sus)}$ , $I_E = 0$ ) ( $V_{CB} = \text{Rated}$ , $V_{CEO(sus)}$ , $I_E = 0$ , $I_C = 100^\circ\text{C}$ )		$I_{CBO}$	— —	1.0 100	$\mu\text{A dc}$
Emitter Cutoff Current ( $V_{BE} = 5.0\text{ Vdc}$ , $I_C = 0$ )		$I_{EBO}$	—	1.0	$\mu\text{A dc}$
<b>ON CHARACTERISTICS</b>					
DC Current Gain ( $I_C = 2.0\text{ Adc}$ , $V_{CE} = 3.0\text{ Vdc}$ )		$H_{FE}$	750	—	
Collector–Emitter Saturation Voltage ( $I_C = 1.5\text{ Adc}$ , $I_B = 6\text{ mA dc}$ )		$V_{CE(Sat)}$	—	1.5	Vdc
Base Emitter Saturation Voltage ( $I_C = 1.5\text{ Adc}$ , $I_B = 6\text{ mA dc}$ )		$V_{BE(Sat)}$	—	2.5	Vdc
Base–Emitter On Voltage ( $I_C = 1.5\text{ Adc}$ , $V_{CE} = 3\text{ Vdc}$ )		$V_{BE(On)}$	—	2.3	Vdc
Output Diode Voltage Drop ( $I_{EC} = 2.0\text{ Adc}$ )		$V_{EC}$	—	2.0	Vdc
<b>DYNAMIC CHARACTERISTICS</b>					
Current Gain Bandwidth Product ( $I_C = 1.0\text{ Adc}$ , $V_{CE} = 2.0\text{ Vdc}$ )		$f_T$	20	—	MHz
		<b>Symbol</b>	<b>Min</b>	<b>Typ</b>	<b>Unit</b>
Turn–On Time ( $I_C = 250\text{ mA}$ , $V_{CE} = 2\text{ V}$ )	BD775–777 BD776–778–780	$t_{on}$	—	250 150	ns
Turn–Off Time ( $I_C = 250\text{ mA}$ , $V_{CE} = 2\text{ V}$ )	BD775–777 BD776–778–780	$t_{off}$	—	600 400	ns

# BD777 BD776 BD778 BD780

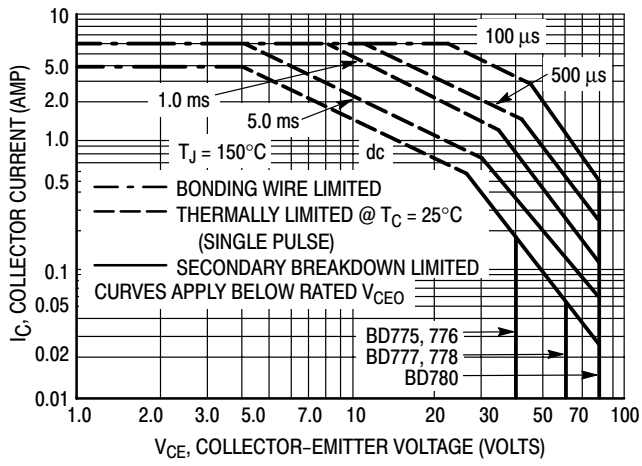

Figure 2. Active Region Safe Operating Area

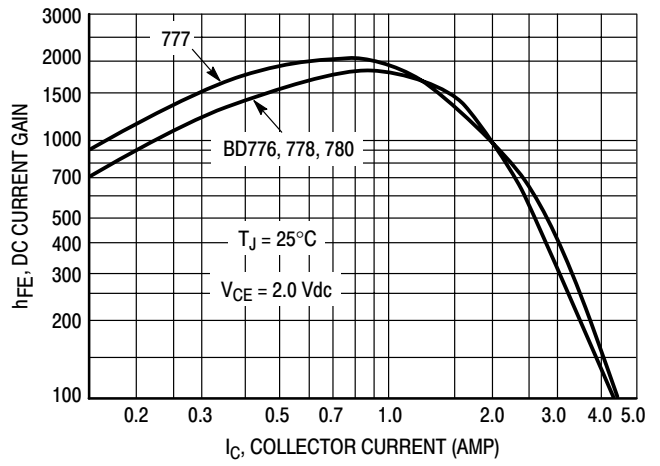

Figure 3. Typical DC Current Gain

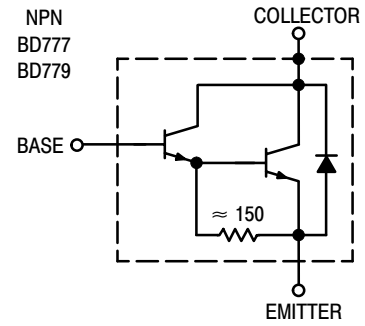
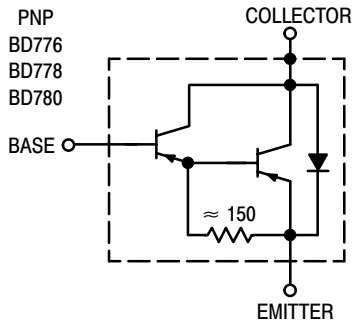
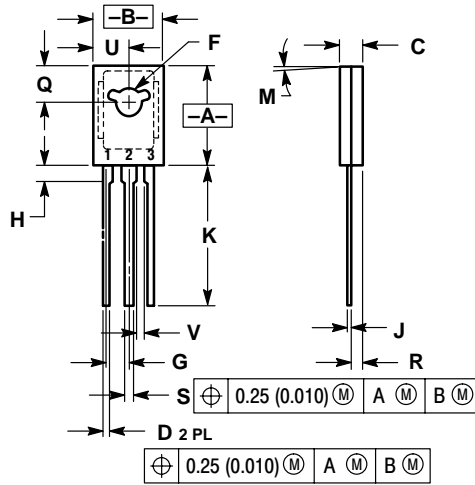

Figure 4. Darlington Circuit Schematic

# BD777 BD776 BD778 BD780

## PACKAGE DIMENSIONS

### CASE 77-08 TO-225AA TYPE ISSUE V



- NOTES:  
1. DIMENSIONING AND TOLERANCING PER ANSI Y14.5M, 1982.  
2. CONTROLLING DIMENSION: INCH.

DIM	INCHES		MILLIMETERS	
	MIN	MAX	MIN	MAX
A	0.425	0.435	10.80	11.04
B	0.295	0.305	7.50	7.74
C	0.095	0.105	2.42	2.66
D	0.020	0.026	0.51	0.66
F	0.115	0.130	2.93	3.30
G	0.094 BSC		2.39 BSC	
H	0.050	0.095	1.27	2.41
J	0.015	0.025	0.39	0.63
K	0.575	0.655	14.61	16.63
M	5° TYP		5° TYP	
Q	0.148	0.158	3.76	4.01
R	0.045	0.055	1.15	1.39
S	0.025	0.035	0.64	0.88
U	0.145	0.155	3.69	3.93
V	0.040	---	1.02	---

- STYLE 1:  
PIN 1. EMITTER  
2. COLLECTOR  
3. BASE

**ON Semiconductor** and  are trademarks of Semiconductor Components Industries, LLC (SCILLC). SCILLC reserves the right to make changes without further notice to any products herein. SCILLC makes no warranty, representation or guarantee regarding the suitability of its products for any particular purpose, nor does SCILLC assume any liability arising out of the application or use of any product or circuit, and specifically disclaims any and all liability, including without limitation special, consequential or incidental damages. "Typical" parameters which may be provided in SCILLC data sheets and/or specifications can and do vary in different applications and actual performance may vary over time. All operating parameters, including "Typicals" must be validated for each customer application by customer's technical experts. SCILLC does not convey any license under its patent rights nor the rights of others. SCILLC products are not designed, intended, or authorized for use as components in systems intended for surgical implant into the body, or other applications intended to support or sustain life, or for any other application in which the failure of the SCILLC product could create a situation where personal injury or death may occur. Should Buyer purchase or use SCILLC products for any such unintended or unauthorized application, Buyer shall indemnify and hold SCILLC and its officers, employees, subsidiaries, affiliates, and distributors harmless against all claims, costs, damages, and expenses, and reasonable attorney fees arising out of, directly or indirectly, any claim of personal injury or death associated with such unintended or unauthorized use, even if such claim alleges that SCILLC was negligent regarding the design or manufacture of the part. SCILLC is an Equal Opportunity/Affirmative Action Employer.

## PUBLICATION ORDERING INFORMATION

### NORTH AMERICA Literature Fulfillment:

Literature Distribution Center for ON Semiconductor  
P.O. Box 5163, Denver, Colorado 80217 USA  
**Phone:** 303-675-2175 or 800-344-3860 Toll Free USA/Canada  
**Fax:** 303-675-2176 or 800-344-3867 Toll Free USA/Canada  
**Email:** ONlit@hibbertco.com  
Fax Response Line: 303-675-2167 or 800-344-3810 Toll Free USA/Canada

### N. American Technical Support: 800-282-9855 Toll Free USA/Canada

### EUROPE: LDC for ON Semiconductor – European Support

**German Phone:** (+1) 303-308-7140 (Mon-Fri 2:30pm to 7:00pm CET)  
**Email:** ONlit-german@hibbertco.com  
**French Phone:** (+1) 303-308-7141 (Mon-Fri 2:00pm to 7:00pm CET)  
**Email:** ONlit-french@hibbertco.com  
**English Phone:** (+1) 303-308-7142 (Mon-Fri 12:00pm to 5:00pm GMT)  
**Email:** ONlit@hibbertco.com

### EUROPEAN TOLL-FREE ACCESS\*: 00-800-4422-3781

\*Available from Germany, France, Italy, UK, Ireland

### CENTRAL/SOUTH AMERICA:

**Spanish Phone:** 303-308-7143 (Mon-Fri 8:00am to 5:00pm MST)  
**Email:** ONlit-spanish@hibbertco.com  
**Toll-Free from Mexico:** Dial 01-800-288-2872 for Access –  
then Dial 866-297-9322

### ASIA/PACIFIC: LDC for ON Semiconductor – Asia Support

**Phone:** 303-675-2121 (Tue-Fri 9:00am to 1:00pm, Hong Kong Time)  
**Toll Free from Hong Kong & Singapore:**  
**001-800-4422-3781**  
**Email:** ONlit-asia@hibbertco.com

### JAPAN: ON Semiconductor, Japan Customer Focus Center

4-32-1 Nishi-Gotanda, Shinagawa-ku, Tokyo, Japan 141-0031  
**Phone:** 81-3-5740-2700  
**Email:** r14525@onsemi.com

### ON Semiconductor Website: <http://onsemi.com>

For additional information, please contact your local Sales Representative.



LittleDiode supplies new, hard to find or obsolete electronic components and semiconductors all over the world.

With over two million different components listed you are sure to find the part you need.

Feel free to visit us today at our online store:

[LittleDiode.com](http://LittleDiode.com)

Looking forward to providing you with the best possible service.