

3Phase spindle motor driver for CD-ROM

BD6669FV

BD6669FV is a 3-phase spindle motor driver adopting 180° PWM direct driving system. Noise occurred from the motor driver when the disc is driven can be reduced. Low power consumption and low heat operation are achieved by using DMOS FET and driving directly.

●Applications

CD-ROM

●Features

- | | |
|--------------------------------------|-----------------------------------------|
| 1) Direct-PWM-Linear driving system. | 6) Built in reverse protection circuit. |
| 2) Built in power save circuit. | 7) Built in short brake circuit. |
| 3) Built in current limit circuit. | 8) Low consumption by MOS-FET. |
| 4) Built in FG-output. | 9) Built in capacitor for oscillator. |
| 5) Built in hall bias circuit. | 10) Built in rotation detect. |

●Absolute maximum ratings (Ta=25°C)

Parameter	Symbol	Limits	Unit
Power supply voltage	V _{CC}	7	V
Supply voltage for motor	V _M	7	V
VG pin voltage	V _G	20	V
Output current	I _{OMAX}	1000 *1	mA
Power dissipation	P _d	1020 *2	mW
Junction temperature	T _{JMAX}	150	°C
Operating temperature range	T _{opr}	-20~+75	°C
Storage temperature range	T _{stg}	-55~+150	°C

*1 However, do not exceed P_d, A_{SO} and T_J=150°C.

*2 70mm×70mm×1.6mm glass epoxy board.

Reduce power by 8.16mW for each degree above 25°C.

●Recommended operating conditions

Parameter	Symbol	Min.	Typ.	Max.	Unit
Power supply voltage	V _{CC}	4.5	–	5.5	V
Supply voltage for motor	V _M	3	–	6.5	V
VG pin voltage	V _G	7.5	–	14	V

This product described in this specification isn't judged whether it applies to cocom regulations.
Please confirm in case of export.

© This product is not designed for protection against radioactive rays.

Motor driver ICs

●Pin descriptions

Pin No.	Pin name	Function
1	A31	Output3 for motor
2	A32	Output3 for motor
3	A21	Output2 for motor
4	A22	Output2 for motor
5	A11	Output1 for motor
6	A12	Output1 for motor
7	VM1	Power supply fo driver
8	VH	Hall bias pin
9	H1 ⁺	Hall input AMP 1 positive input
10	H1 ⁻	Hall input AMP 1 negative input
11	H2 ⁺	Hall input AMP 2 positive input
12	H2 ⁻	Hall input AMP 2 negative input
13	H3 ⁺	Hall input AMP 3 positive input
14	H3 ⁻	Hall input AMP 3 negative input
15	GND	GND
16	CP1	Capacitor pin 1 for charge pump
17	CP2	Capacitor pin 2 for charge pump
18	VPUMP	Capacitor connection pin for charge pump
19	CNF	Capacitor connection pin for phase compensation
20	SB	Short brake pin
21	RNF2	Resistor connection pin for current sense
22	VCC	Power supply for signal division
23	VM2	Power supply for driver
24	ECR	Torque control standard voltage input terminal
25	EC	Torque control voltage input terminal
26	FG	FG output pin
27	PS	Power save pin
28	RNF1	Resistor connection pin for current sense

Motor driver ICs

● Input output circuits

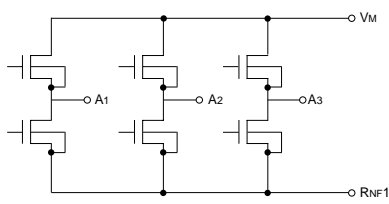
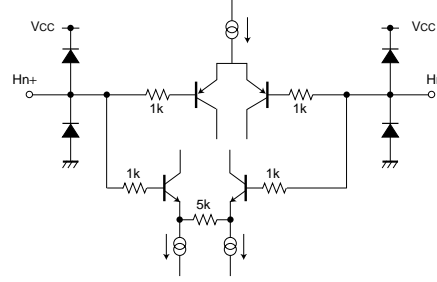
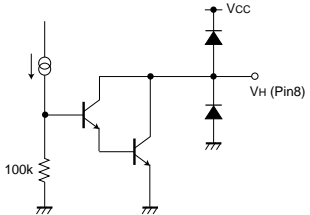
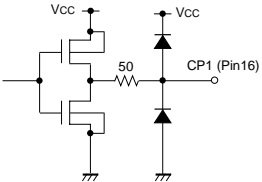
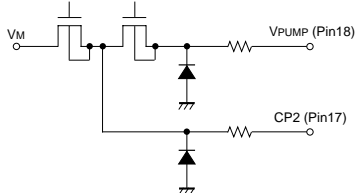
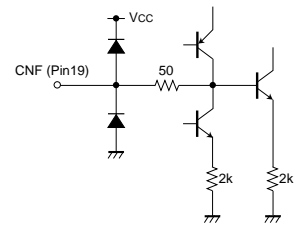
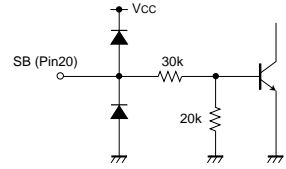
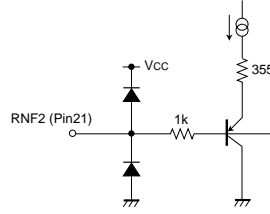
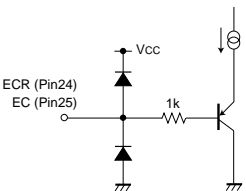
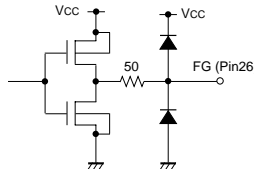
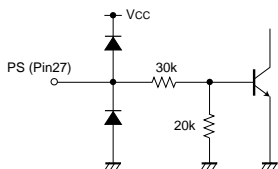
<p>Output pins A1 : Pin1, 2, A2 : Pin3, 4, A3 : Pin5, 6</p> 		<p>Hall input H1+ : Pin9, H1- : Pin10, H2+ : Pin11, H2- : Pin12, H3+ : Pin13, H3- : Pin14</p> 		
<p>Hall bias Pin8</p> 	<p>CP1 output Pin16</p> 	<p>CP2 / VPUMP output CP2 : Pin17, VPUMP : Pin18</p> 		
<p>CNF Pin19</p> 	<p>Short brake Pin20</p> 		<p>RNF2 Pin21</p> 	
<p>Torque amplifier ECR : Pin24, EC : Pin25</p> 		<p>FG output FG : Pin26</p> 		<p>Power save Pin27</p> 

Motor driver ICs

●Electrical characteristics (unless otherwise noted, Ta=25°C, VCC=5V, VM=5V)

Parameter	Symbol	Min.	Typ.	Max.	Unit	Conditions	Test Circuit
<Total>							
Circuit current 1	I _{CC1}	–	–	5	μA	Sutand by mode	Fig.2
Circuit current 2	I _{CC2}	5	11	17	mA		Fig.2
<Power save>							
ON voltage range	V _{PSON}	–	–	1.0	V	Sutand by mode	Fig.2
OFF voltage range	V _{PSOFF}	2.5	–	–	V		Fig.2
<Hall bias>							
Hall bias voltage	V _{HB}	0.6	1.0	1.4	V	I _{HB} =10mA	Fig.2
<Hall AMP>							
Input bias current	I _{HA}	–8.0	–2.0	–	μA		Fig.4
In-phase input voltage range	V _{HAR}	1.4	–	3.6	V		Fig.4
Minimum input level	V _{INH}	100	–	–	mV _{PP}	Hall input Amp	Fig.4
Hall hysteresis level (+)	V _{HYS+}	5	20	40	mV		Fig.8
Hall hysteresis level (–)	V _{HYS–}	–40	–20	–5	mV		Fig.8
<Torque control>							
Input voltage range	E _C , E _{CR}	0	–	5	V	Linear range 0.5V~3.3V	Fig.6
Offset voltage (+)	E _{cofs+}	5	50	100	mV		Fig.6
Offset voltage (–)	E _{cofs–}	–100	–50	–5	mV		Fig.6
Input current	E _{CIN}	–12	–2.5	–	μA	E _C =E _{CR} =1.65V	Fig.6
<Short brake SW>							
ON voltage range	V _{SBON}	2.5	–	–	V	Short brake	Fig.7
OFF voltage range	V _{SBOFF}	–	–	1.0	V		Fig.7
<Output>							
Input / Output gain	G _{EC}	0.8	1.0	1.2	A/V		Fig.6
Output ON-resistance	R _{ON}	0.3	0.5	0.7	Ω	I _O =±600mA (Upper+Lower)	Fig.5
Torque limit voltage	V _{TL}	0.16	0.2	0.24	V		Fig.3
<FG output>							
High voltage	V _{FGH}	4.6	–	–	V	I _{FG} =–100μA	Fig.6
Low voltage	V _{FGL}	–	–	0.4	V	I _{FG} =+100μA	Fig.6
<Charge pump voltage>							
Charge pump output voltage	V _{pump}	6	10	14	V	V _{CC} =V _M =5V	Fig.9

●Measuring circuit

1. Value of resistor (Fig.2~Fig.9)

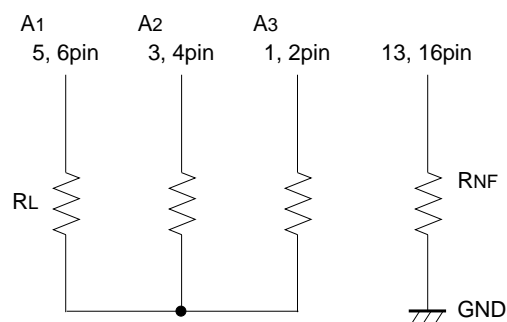

$$R_L=5\Omega, R_{NF}=0.33\Omega$$

Motor driver ICs

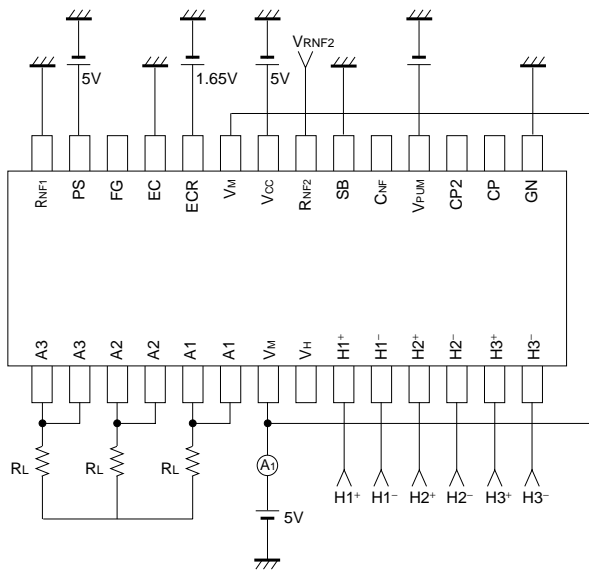

V_{TL} : Range of V_{RNF2} that V_m current (I_m) become 0A.
 $V_{PS}=5$ [V]

Fig.3

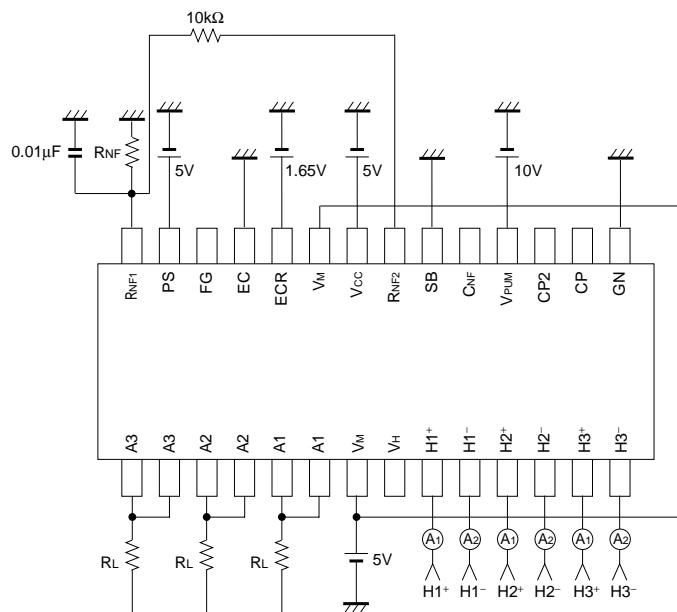

I_{HA} : Value of 'A1' ($H_n^+=2.5V, H_n^-=2.0V$)
 Value of 'A2' ($H_n^+=2.0V, H_n^-=2.5V$)
 $n=1, 2, 3$

V_{HAR} : HALL voltage range that output pins become input-output table.

V_{INH} : HALL input level that output pins become input-output table.

$$V_{INH} : \begin{cases} |H_n^+ - H_n^-| \\ H_n^- = 2.5V \end{cases}$$

Fig.4

Motor driver ICs

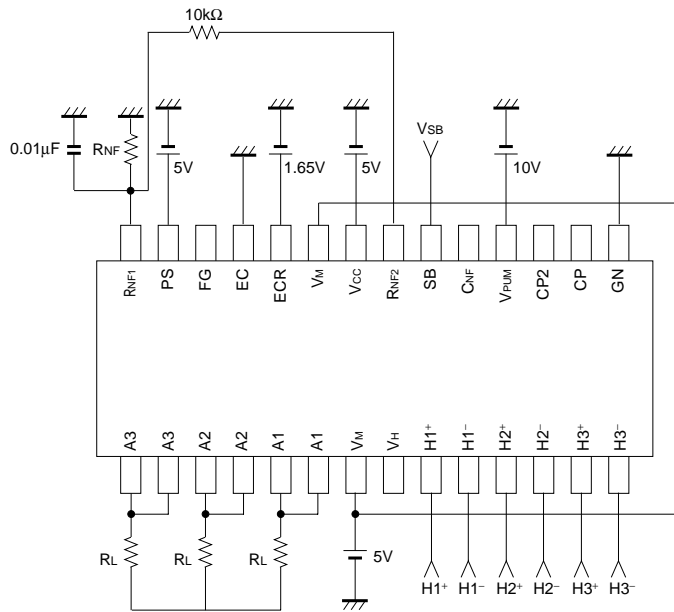

V_{SBON} : Voltage range of 'Vsb' that output pins become 'L'.

V_{SBOFF} : Range of 'Vsb' that output pins become input-output table.

Fig.7

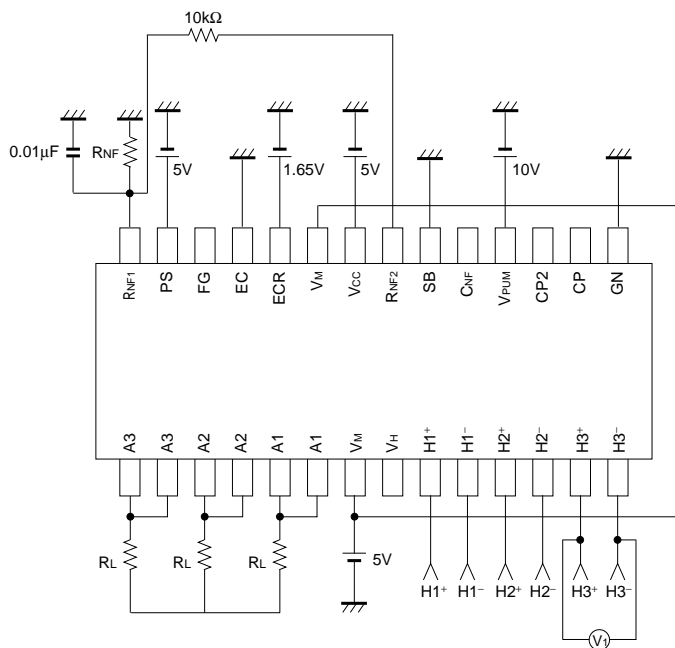

V_{HYS} : Voltage difference H3+ to H3- that FG voltage change V1.

Fig.8

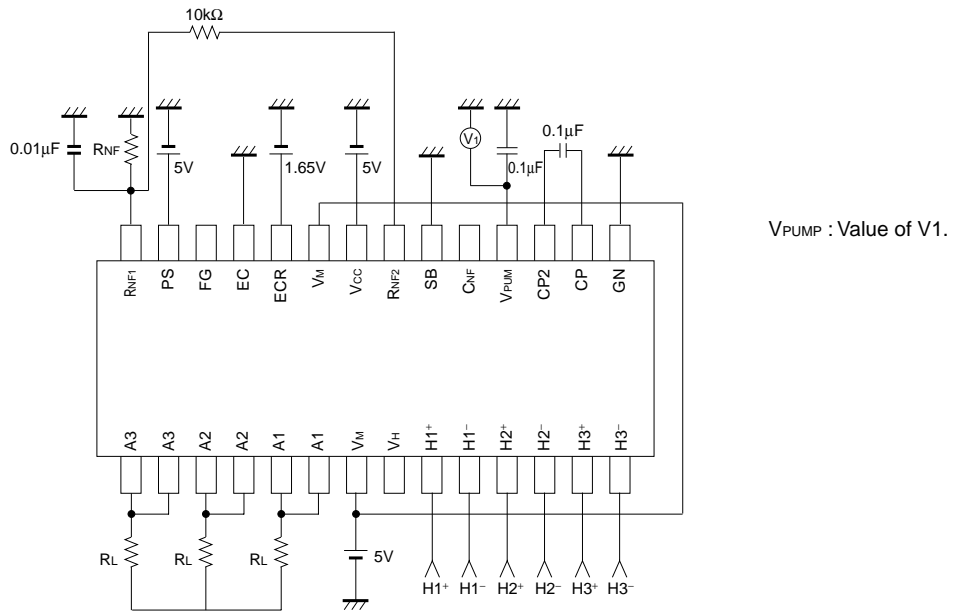

Fig.9

Motor driver ICs

●Circuit operation

1. Application

(1) Hall input

Hall element can be used with both series and parallel connection. Determining R1 and R2, make sure to leave an adequate margin for temperature and dispersion in order to satisfy in-phase input voltage range and minimum input level.

A motor doesn't reach the regular number of rotation, if hall input level decrease under high temperature.

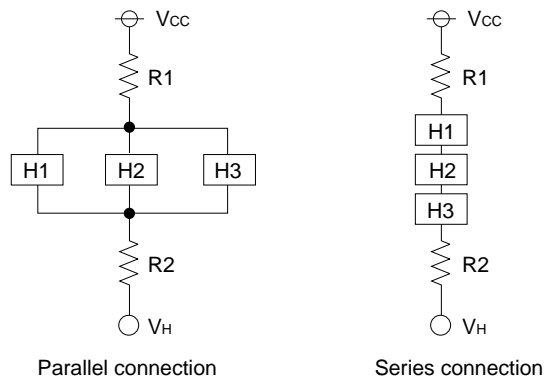

Fig.10

2. Torque voltage

By the voltage difference between EC and ECR, the current driving motor changes as shown in Fig.11 below.

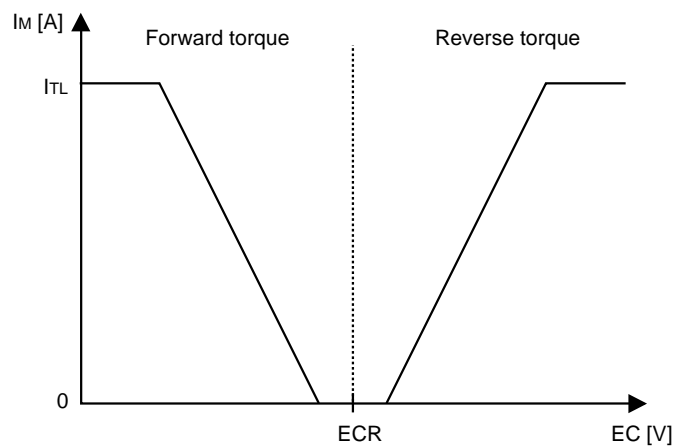

Fig.11

The gain of the current driving motor for the voltage of EC can be changed by the resistance of RNF.

Motor driver ICs

(3) Current limit

The maximum value of the current driving motor can be changed by the resistance of RNF.

$$I_{TL} = 0.2 / RNF \text{ (A)}$$

(4) Short brake

The short brake is switched by SB pin and its operation is shown in table below.

SB	EC < ECR	EC > ECR
L	Rotating forward	Reverse brake
H	Short brake	Short brake

Output upper (3phase) FET turn off and lower (3phase) FET turn on in short brake mode, as shown Fig.12.

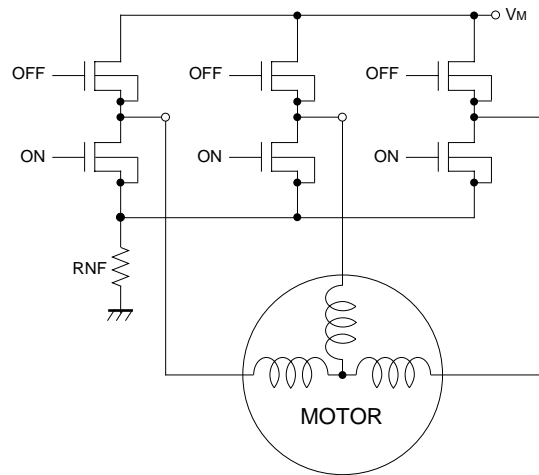

Fig.12

(5) Reverse detection

Reverse detection is constructed as shown in Fig.13. Output is opened when EC>ECR and the motor is rotating reverse.

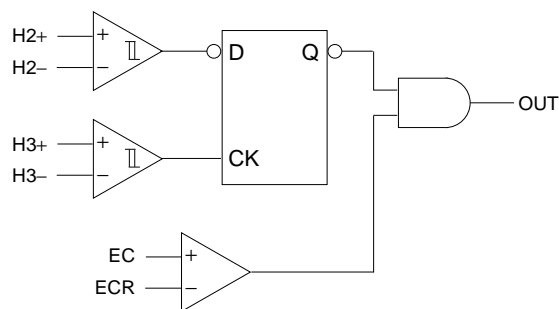
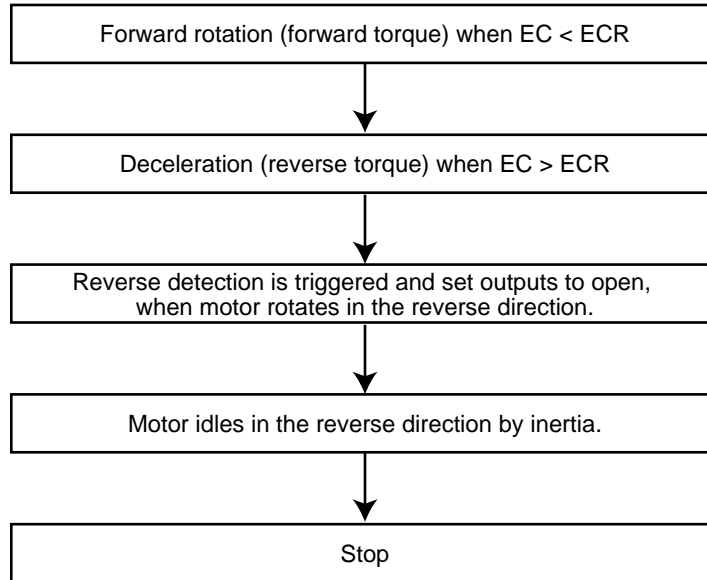

Fig.13

Motor rotation at reverse detection

Motor driver ICs

(6) Timing chart

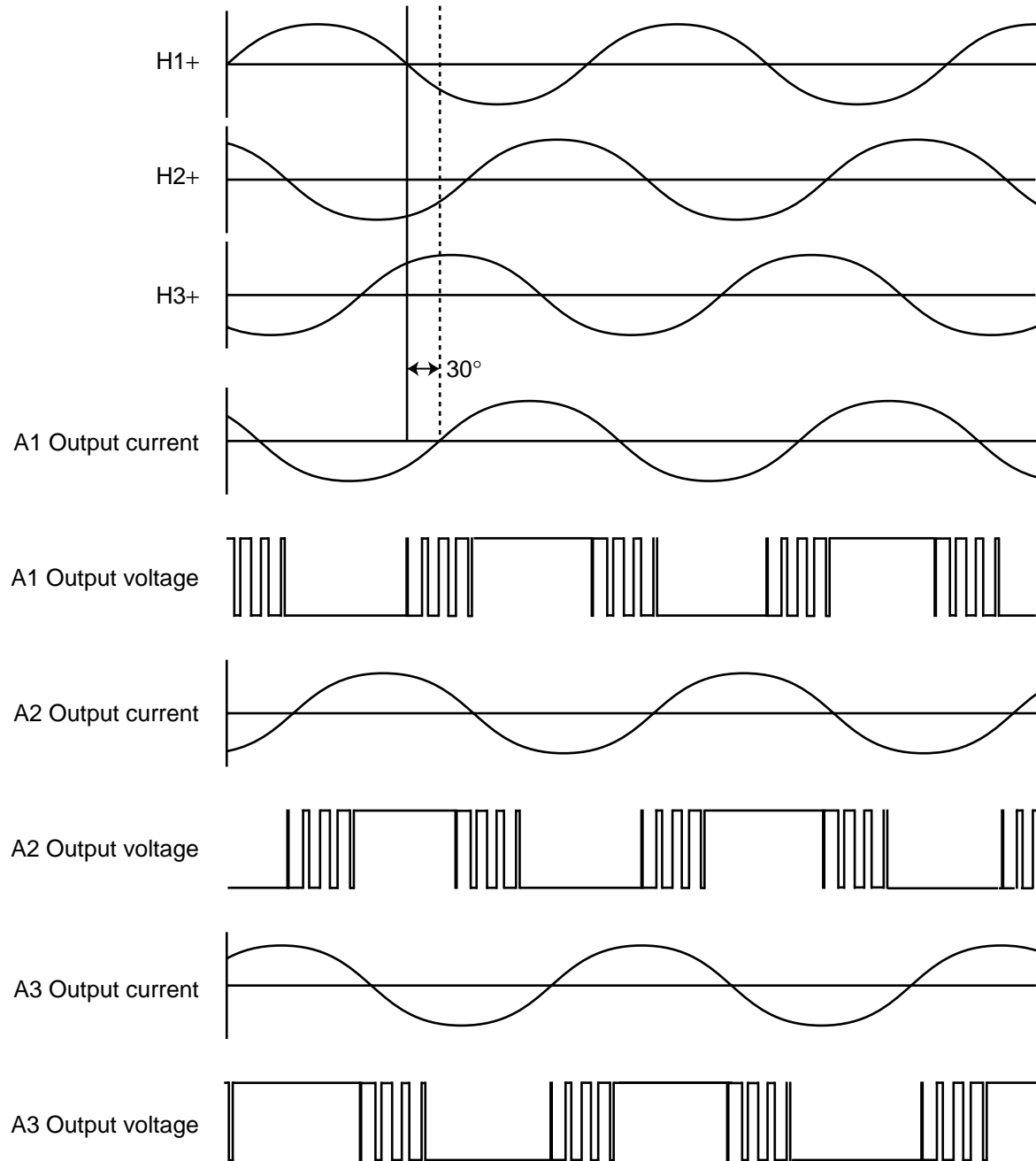

Fig.14

Motor driver ICs

●Application example

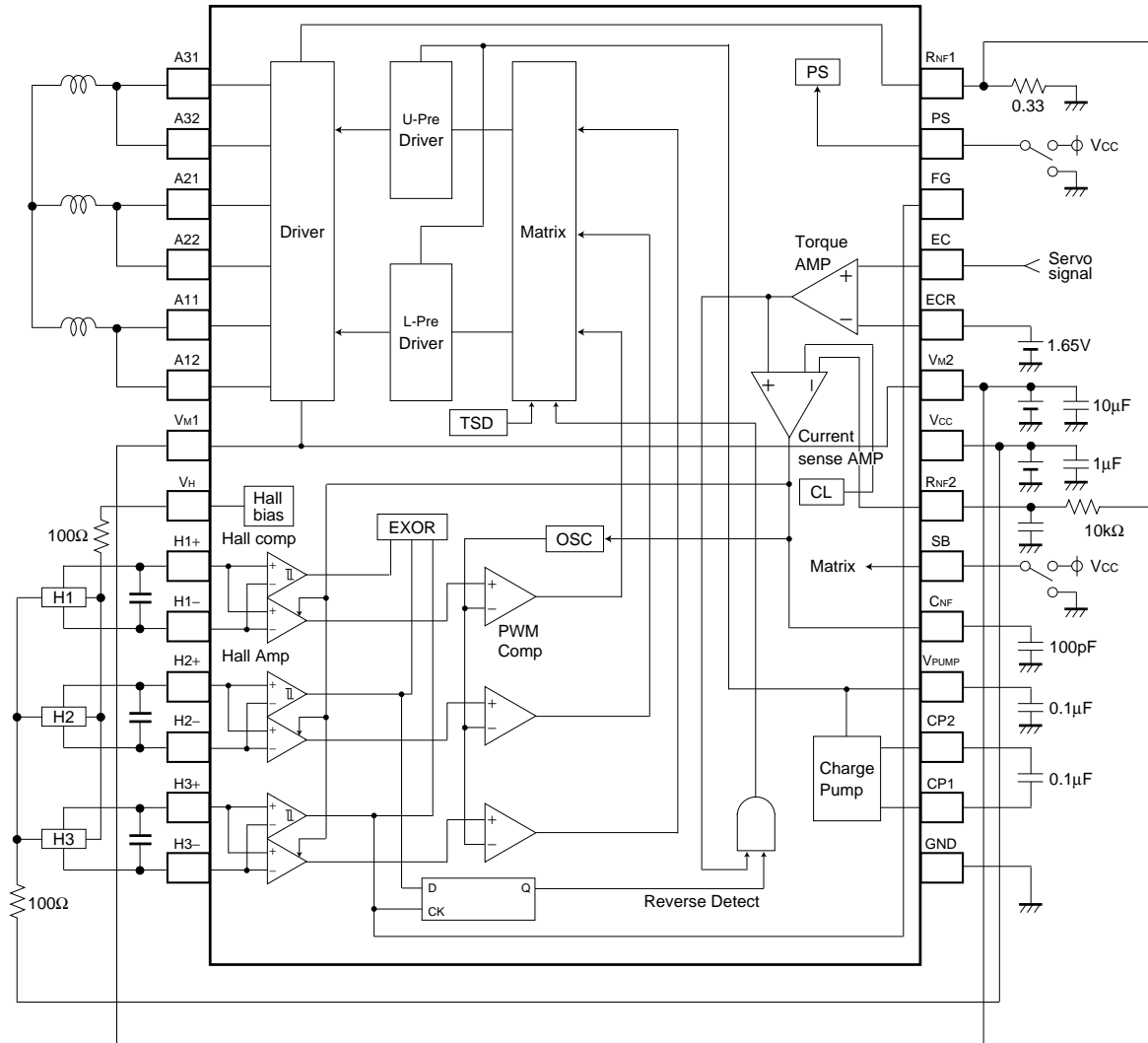

Fig.15

●Operation notes

1. Absolute maximum ratings

Absolute maximum ratings are those values which, if exceeded, may cause the life of a device to become significantly shortened. Moreover, the exact failure mode cannot be defined, such as a short or an open. Physical countermeasures, such as a fuse, need to be considered when using a device beyond its maximum ratings.

2. GND potential

The GND terminal should be the location of the lowest voltage on the chip. All other terminals should never go under this GND level, even in transition.

Motor driver ICs

3. Thermal design

The thermal design should allow enough margin for actual power dissipation.

4. Mounting failures

Mounting failures, such as misdirection or mismounts, may destroy the device.

5. Electromagnetic fields

A strong electromagnetic field may cause malfunctions.

6. Coil current flowing into VM

A coil current-flows from motor into VM when torque control input changes from EC<ECR into EC>ECR, and VM voltage rises if VM voltage source doesn't have an ability of current drain.

Make sure that surrounding circuits work correctly and aren't destroyed, when VM voltage rises.

Physical countermeasures, such as a diode for voltage clamp, need to be considered under these conditions.

7. CNF pin

An appropriate capacitor (100pF (typ.)) at CNF pin make motor current smooth. Make sure the motor current doesn't oscillate, even in transition.

●Electrical characteristics curve

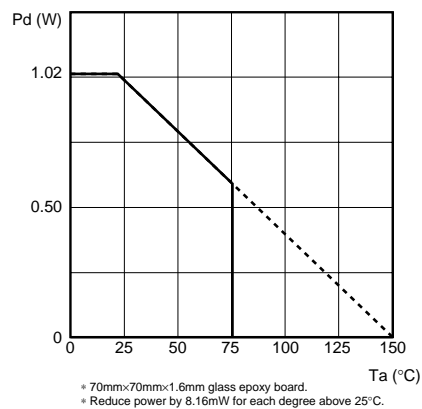
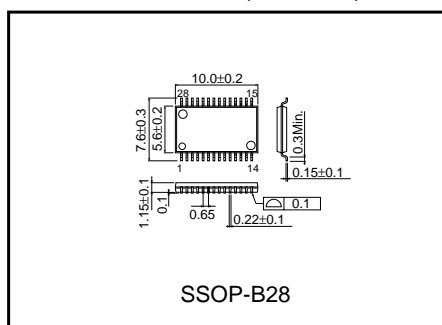

Fig.16 Power dissipation curve

●External dimensions (Units : mm)





LittleDiode supplies new, hard to find or obsolete electronic components and semiconductors all over the world.

With over two million different components listed you are sure to find the part you need.

Feel free to visit us today at our online store:

LittleDiode.com

Looking forward to providing you with the best possible service.