

System Motor Driver IC for PB/REC portable MD

BD6603KVT

●Description

The BD6603KVT is developed for motor drivers used in portable MD players. This IC includes : a 3-phase full-wave sensorless operating system, a 4-channel H-bridge driver for focus, a sled, tracking for the spindle motor and Head step-up, and a 2-channel half-bridge driver for VM PWM voltage control. VG step-up is accomplished through a charge-pump circuit.

●Dimension (Units : mm)

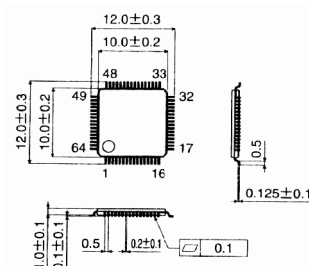

TQFP64V

●Features

- 1) Single chip and thin packaging allow for a smaller set design
- 2) Low power consumption due to low ON resistance power MOS output
- 3) Low voltage operating (2.3V min.)

●Applications

REC portable MD player, Data MD

●Absolute Maximum Ratings (Ta=25°C)

Parameter	Symbol	Limits	Unit
Control circuit supply voltage	V _{CC}	7	V
Supply voltage (Driver)	V _M	7	V
Supply voltage (Pre-driver)	V _G	15	V
Output current	I _{omax}	500 ¹	mA
Power dissipation	P _d	1250 ²	mW
Operating temperature range	T _{opr}	-25 ~ +75	°C
Storage temperature range	T _{stg}	-55 ~ +150	°C

¹ Derating : 10mW/°C for operation above Ta=25°C.

² 70mm 70mm 1.6mm glass epoxy board.

Do not, however exceed Pd, ASO

●Recommended Operating Conditions (Ta=25°C)

Parameter	Symbol	Min.	Typ.	Max.	Unit
Power supply voltage	V _{CC}	2.3	3.0	6.5	V
	V _M	—	—	6.5	V
	V _G	V _M +3	9	14	V
Pulse input frequency	f _{in}	—	—	200	KHz

●Electrical characteristics (Unless otherwise noted, Ta=25°C, Vcc=3V, VM=2.5V, fin=176KHz)

Parameter	Symbol	Min.	Typ.	Max.	Unit	Conditions
Circuit current	Icc	—	5.6	8.0	mA	(All blocks) operating
	IST	—	16	50	μA	(All blocks) stand-by
Output ON resistance	RON	—	0.8	1.2		ON resistance (upper+Lower) VG=10V
<Step-up circuit>						
Output voltage	VG1	7.5	8.9	10.0	V	Each input L
	VG2	6.0	7.3	9.5	V	(All blocks) operating
<Spindle (3-phase full-wave sensorless driver)>						
Position detection comparator offset	VCO	-10	—	+10	mV	
Detection comparator input range	VCD	0	—	Vcc-1.0	V	
Brake comparator input current	IBR	—	—	2.0	μA	BRK=VCC
Brake comparator input offset	VBO	-15	—	+15	mV	
Brake comparator input range	VBD	0	—	Vcc-1.5	V	
FG output L voltage	VOLF	—	0.2	0.3	V	Io=500μA
<Sled, focus/tracking, head step-up, PWM power supply (H bridge, half bridge driver)>						
Logic H level input voltage	VINH	Vcc-0.4	—	—	V	
Logic L level input voltage	VINL	—	—	0.4	V	
Logic H level input current	IINH1	—	—	1	μA	VIN=3V
	IINH2	—	350	600	μA	VIN=3V EXTCLK pin
Logic L level input current	IINL	-1	—	—	μA	VIN=0V
Output propagation delay time	TRISE	—	0.2	1	μsec	
	TFALL	—	0.1	0.7	μsec	

※This product is not designed for protection against radioactive rays.

●Application circuit

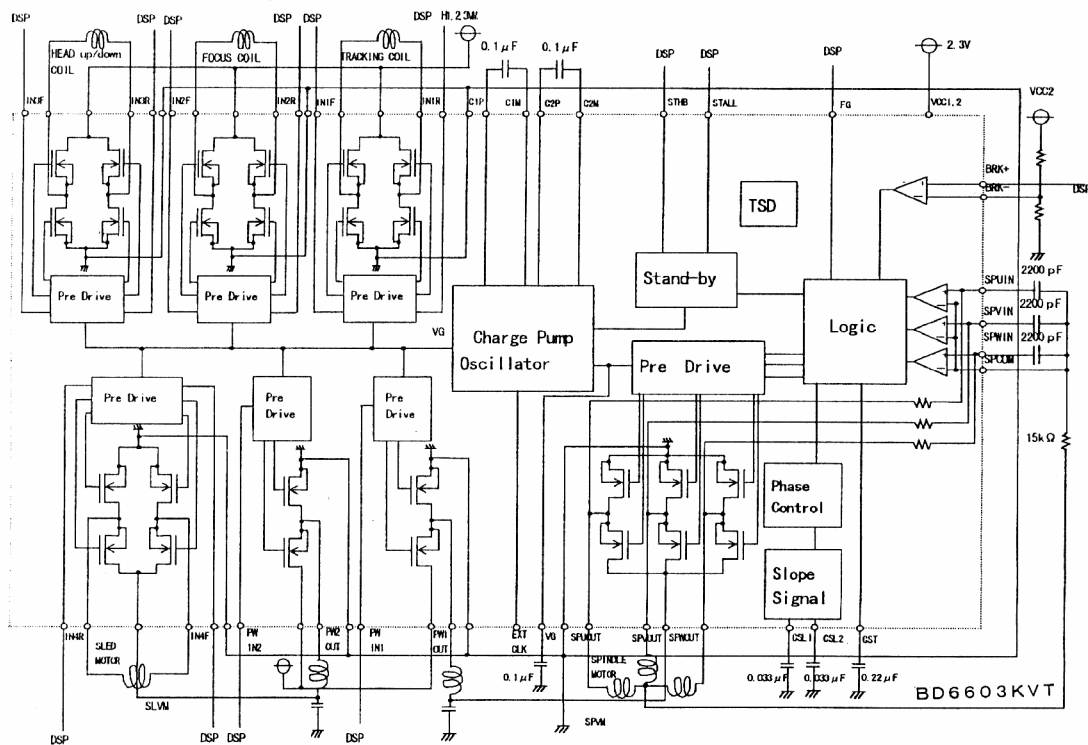



LittleDiode supplies new, hard to find or obsolete electronic components and semiconductors all over the world.

With over two million different components listed you are sure to find the part you need.

Feel free to visit us today at our online store:

LittleDiode.com

Looking forward to providing you with the best possible service.