

Power management switch BD6522F

●Description

BD6522F is a power management switch IC that includes Low ON resistance MOSFET. The built-in soft start circuit and the error detection circuit protect output. In addition, this IC includes discharge circuit that discharge residual voltage when the output is OFF.

●Dimension (Units : mm)

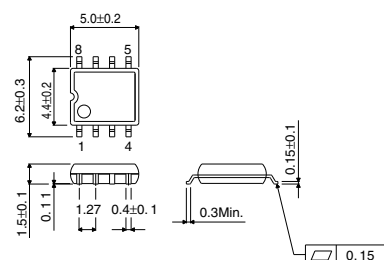

SOP8

●Features

- 1) Low ON resistance switch: Typ.=50mΩ
- 2) Output current capacity: 0~2 A
- 3) Reverse current prevention when the switch is OFF.
- 4) Built-in soft start circuit
- 5) UVLO
- 6) Temperature protection circuit with latch function
- 7) Built-in discharging circuit (When output is OFF.)

●Applications

Battery driven equipment such as notebook PC, PDA etc.

●Absolute Maximum Ratings (Ta=25°C)

Parameter	Symbol	Limits	Unit
Supply voltage	V _{DD}	-0.3 ~ +6.0	V
CTRL pin voltage	V _{CTRL}	-0.3 ~ +6.0	V
Output pin voltage	V _{OUT}	-0.3 ~ V _{DD} +0.3	V
Storage temperature range	T _{STG}	-55 ~ +125	°C
Power dissipation	P _d	450 *	mW

*Derating : 4.5mW/°C for operation above Ta=25°C

©This product is not designed for protection against radioactive rays.

● Recommended Operating Conditions (Ta=25°C)

Parameter	Symbol	Min.	Typ.	Max.	Unit
Operating voltage range	V _{DD}	3.0	—	5.5	V
Switch current	I _{SW}	0	—	2	A
Operating temperature range	T _{OPR}	—25	—	+85	°C

● Electrical characteristics (Unless otherwise noted : Ta=25°C, V_{DD}=5V)

Parameter	Symbol	Min.	Typ.	Max.	Unit	Conditions
ON resistance	R _{ON1}	—	50	70	mΩ	V _{DD} =5V, V _{CTRL} =5V
	R _{ON2}	—	60	85	mΩ	V _{DD} =3.3V, V _{CTRL} =3.3V
VDD operating current	I _{DD}	—	110	220	μA	V _{CTRL} =5V, OUT=OPEN
	I _{DDST}	—	—	2	μA	V _{CTRL} =0V, OUT=OPEN
CTRL input voltage	V _{CTRL_L}	—	—	0.7	V	V _{CTRL} =Low Level
	V _{CTRL_H}	2.5	—	—	V	V _{CTRL} =High Level
CTRL input current	I _{CTRL}	—1	0	1	μA	V _{CTRL} =L, H
OUT rise time	T _{ON}	—	1000	3500	μS	R _L =10Ω, SSCTL=OPEN CTRL=H->OUT=90%
OUT fall time	T _{OFF}	—	4	20	μS	R _L =10Ω, SSCTL=OPEN CTRL=L->OUT=10%
Switch discharge resistance	R _{SWDC}	—	350	600	Ω	V _{DD} =5V, V _{CTRL} =0V
UVLO detection voltage	V _{UVLO_H}	2.3	2.5	2.7	V	V _{DD} increasing
	V _{UVLO_L}	2.1	2.3	2.5	V	V _{DD} decreasing
UVLO hysteresis voltage	V _{HYS}	100	200	300	mV	V _{HYS} =V _{UVLO_H} —V _{UVLO_L}
Over temperature threshold	T _{TS}	—	135	—	°C	V _{CTRL} =5V

● Block Diagram

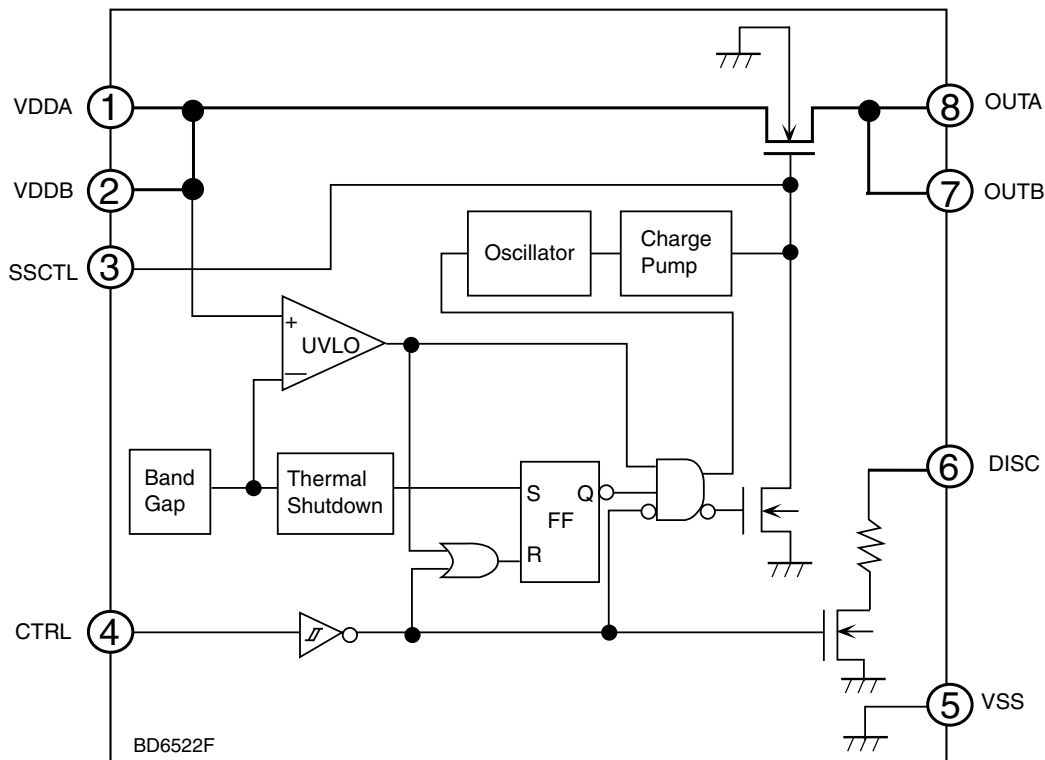



LittleDiode supplies new, hard to find or obsolete electronic components and semiconductors all over the world.

With over two million different components listed you are sure to find the part you need.

Feel free to visit us today at our online store:

LittleDiode.com

Looking forward to providing you with the best possible service.