

DC/DC converter for LCD back light

BD6155FVM

BD6155FVM is an ideal IC to drive white LED used for the LCD back light of cellular phones, and PDA etc. This IC incorporates charging pump step-up circuit to drive white LED with high V_F . It also integrates a driver to drive white LED with 4-step constant current. Only one external resistor can set the current value.

●Applications

Small portable appliances, such as cellular phones, PHS, PDA
Battery-powered equipments using the white LED.

●Features

- 1) Built-in charging pump step-up circuit.
- 2) Built-in constant current driver for LED. (Current value : 4 steps variable)
- 3) Ultra small MSOP8 package. (Height 0.9mm Max.)

●Absolute maximum ratings (Ta=25°C)

Parameter	Symbol	Limits	Unit
Maximum supply voltage	V _{BAT}	-0.3~+6.0	V
Maximum input voltage	V _{IN}	-0.3~+6.0	V
Power dissipation	P _d	350 *	mW
Operating temperature	T _{opr}	-25~+75	°C
Storage temperature	T _{stg}	-55~+125	°C

* Reduce to 3.5mW/°C when Ta=25°C or above.

●Recommended operating conditions (Ta=25°C)

Parameter	Symbol	Min.	Typ.	Max.	Unit
Power supply	V _{BAT}	2.9	-	5.5	V

Communication ICs

●Block diagram

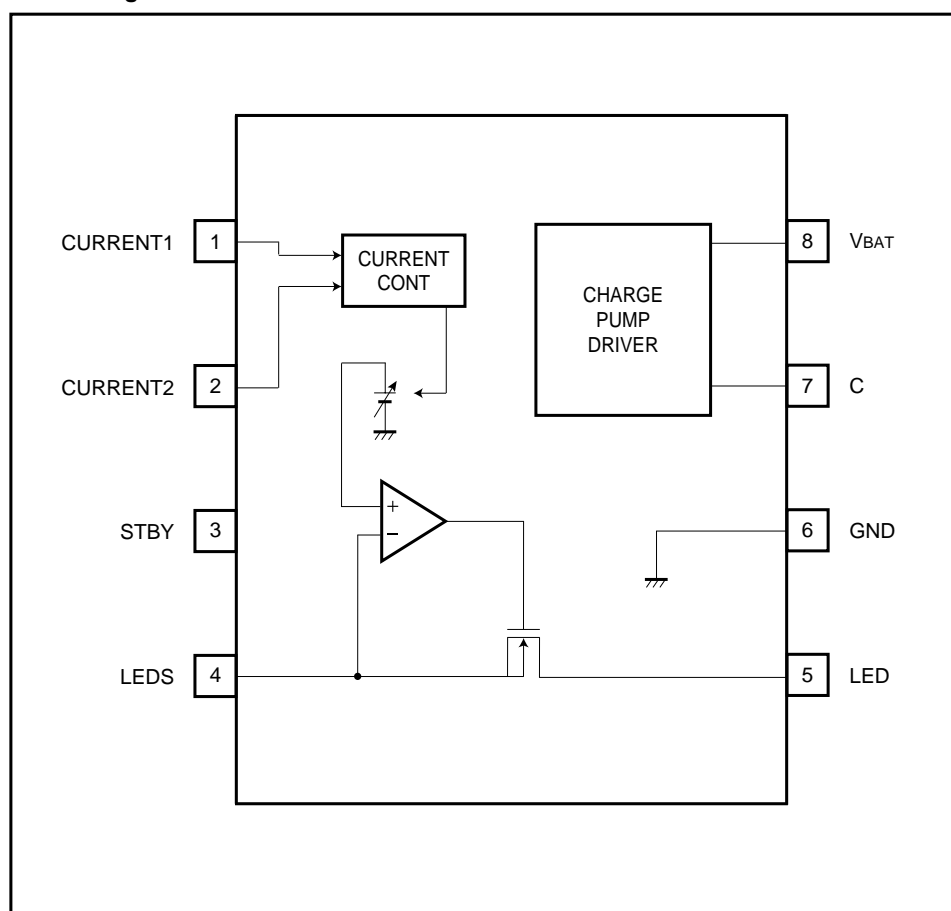

●Pin descriptions

Pin No.	Pin Name	Function
1	CURRENT1	Fixed current setup pin1.
2	CURRENT2	Fixed current setup pin2.
3	STBY	Stand-by pin (High:Operation, Low:No operation)
4	LEDS	LED driver current pin (Fixed current sink pin)
5	LED	LED cathode connection pin for charge pump
6	GND	Ground
7	C	Capacitor connection pin for charge pump
8	VBAT	Power supply voltage input pin

Communication ICs

●Electrical characteristics (unless otherwise noted, Ta=25°C, VBAT=3.6V, STBY=3.6V)

Parameter	Symbol	Min.	Typ.	Max.	Unit	Conditions
<LED+Charge pump block>						
Circuit current	Iq1	-	0.3	1.0	mA	No load
Standby current	Iq2	-	-	5	μA	No load, STBY=0V
<Fixed current driver for LED>						
LED max drive current	I _{LED} MAX	-	-	80	mA	
NMOS ON resistance	R _{on7}	-	3	7	Ω	Drive current 80mA
Current control setup voltage 1	ΔV _{LED1}	184	205	226	mV	CURRENT2=High, CURRENT1=High
Current control setup voltage 2	ΔV _{LED2}	131	155	179	mV	CURRENT2=High, CURRENT1=LOW
Current control setup voltage 3	ΔV _{LED3}	89	105	121	mV	CURRENT2=LOW, CURRENT1=High
Current control setup voltage 4	ΔV _{LED4}	42	55	68	mV	CURRENT2=LOW, CURRENT1=LOW
Fixed current setup pin control voltage	Hi	V _{IH}	2.0	-	-	V
	Low	V _{IL}	-0.3	-	0.3	V
<Charge pump>						
Oscillator frequency	fosc	-	120	-	kHz	
Output voltage 1	VDC1	4.8	5.6	-	V	VBAT=3.6V, I _o =80mA charge pump output monitor RB521-S30 use
Output voltage 2	VDC2	4.4	4.8	-	V	VBAT=3.2V, I _o =60mA charge pump output monitor RB521-S30 use
Stand-by pin pull down resistor	RSTBY	250	400	700	kΩ	
Stand-by pin control voltage	Active	V _{IH}	2.0	-	-	V
	Stand-by	V _{IL}	-0.3	-	0.3	V

© This product is not designed for protection against radioactive rays.

●Measurement circuit

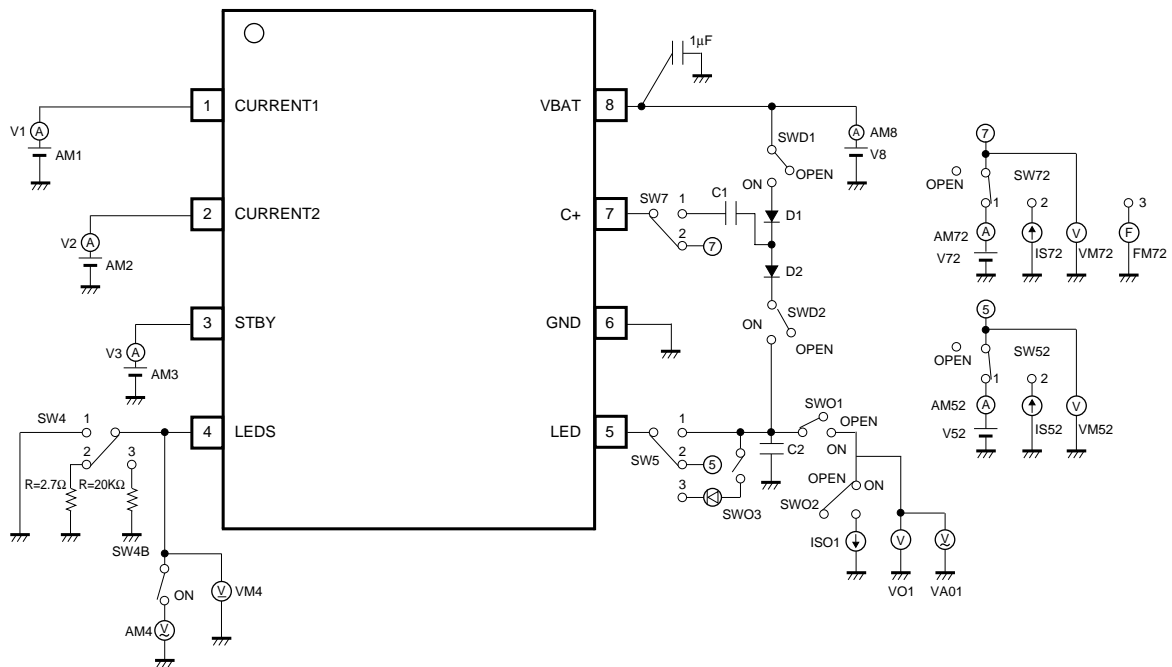

Fig.1

Communication ICs

●Circuit operation

1) Charge pump driver

Charge pump is consisted capacitor pin (pin7), external schotky diodes and capacitors.

Output voltage at no loading is 2VBAT-2VF. (VF is as same as schotky's VF)

Output voltage at loading is referred Fig2. As standard example, however it depends on external components.

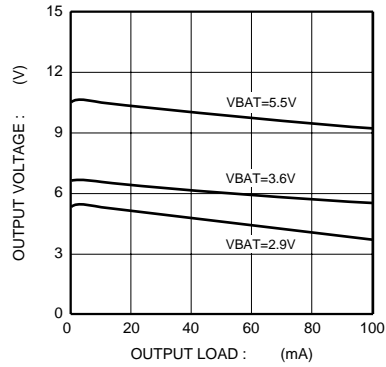
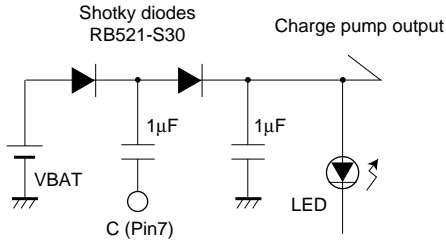

Fig.2 Charge pump loading characteristics (Typical operating characteristics)

2) Fixed current driver

LED driver fixed current is determined by resistor value between LED pin (pin4) and GND.

At current control set up voltage1 (Current1, 2=High) resistor value between LED-GND is set as 2.7Ω.

$$205\text{mV} \div 2.7\Omega = 75.9\text{mA} \dots (2 \text{ expressions})$$

The above current is loaded to LED as fixed current.

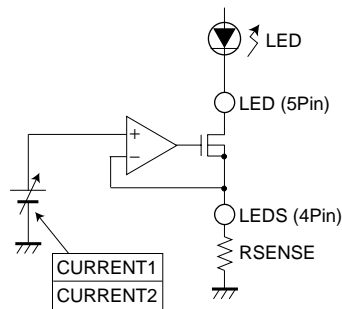

● LED drive current fix example

	LEDS pin voltage (mV)	LED drive current (mA)	
		RSENSE=2.7Ω	RSENSE=5.1Ω
Current control setup voltage 1 (Current 1=High Current 2=High)	205.0	75.9	40.2
Current control setup voltage 2 (Current 1=Low Current 2=High)	155.0	57.4	30.4
Current control setup voltage 3 (Current 1=High Current 2=Low)	105.0	38.9	20.6
Current control setup voltage 4 (Current 1=Low Current 2=Low)	55.0	20.4	10.8

The less RSENSE, the bigger fixed current for LED drive.

Resistors value should be determined with confirmation of charge pump loading characteristics (Fig.2) and LED's I-V characteristics.

Communication ICs

●Design information

1. The maximum of power loss of this IC is controlled by the output transistor M1 in regulator driver.

Relations of the power supply voltage are signified in 2 expressions with this loss.

$$\Delta V = V_{OUT} - (VF2 + I_{LED} \times R1 + V_{LED})$$

The loss in M1,

$$\Delta V \times I_{LED} = I_{LED} \times \{2V_{BAT} - (2VF1 + VF2 + I_{LED} \times R1 + V_{LED})\} \dots (2 \text{ expressions})$$

ΔV ; The voltage between LED-LEDS

$VF1$; Shotky's Di VF

$VF2$; LED's VF

V_{OUT} ; Charge pump output voltage (Fig.2)

V_{LED} ; The voltage across RSENSE (examples at 205mV calculation)

I_{LED} ; Drive current.

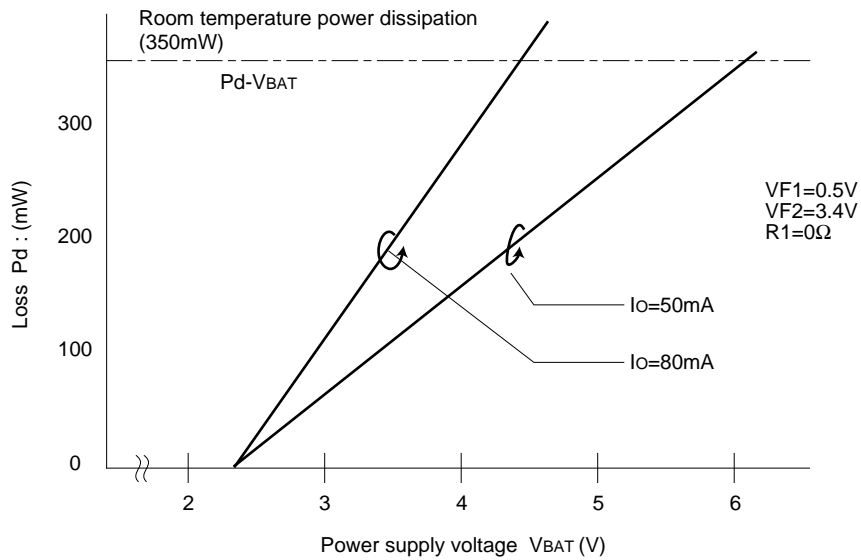
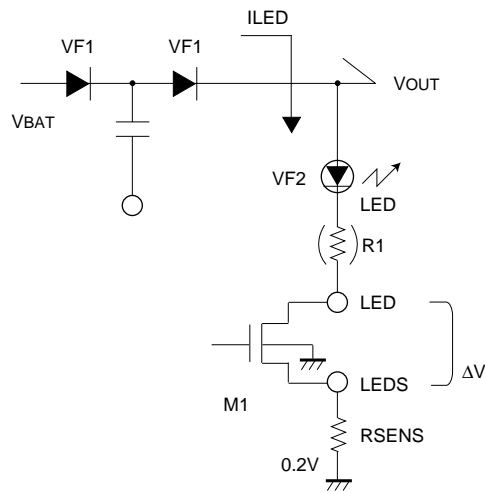

2) Power supply voltage

The thermal shutdown circuit turn on, and output electric current declines when chip temperature is about 125 degrees due to low electric current driver.

Communication ICs

●Application example

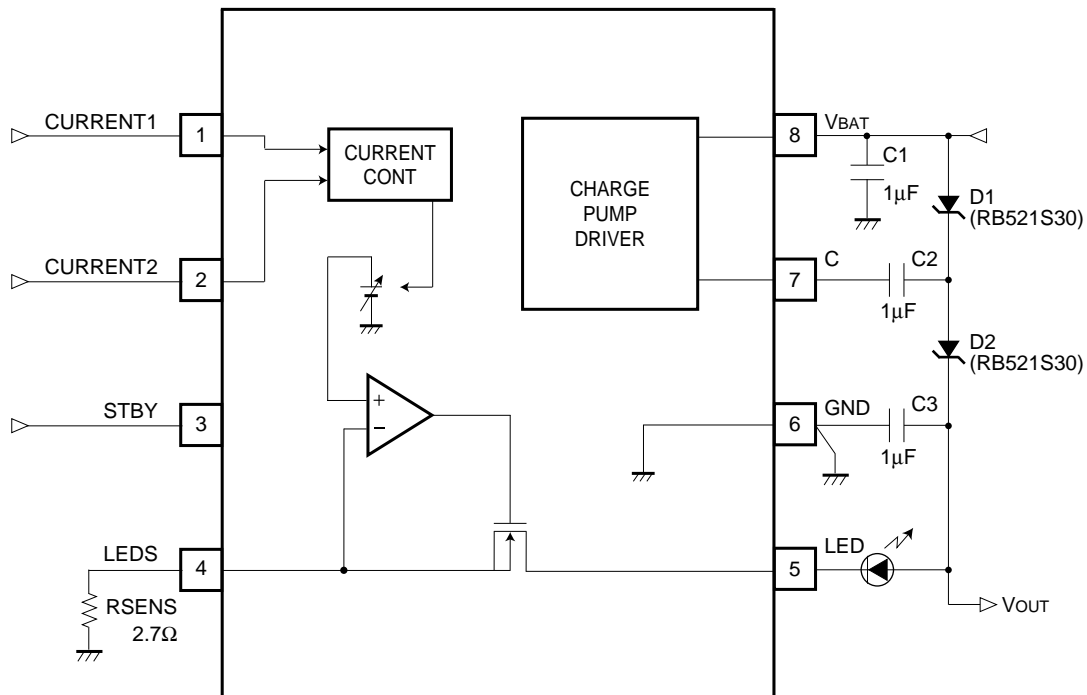

●Attached components

- (1) We recommend capacitor with lower ESR.
- (2) We recommend capacitor with is good characteristics to temperature.
- (3) Mount all capacitor as close together as possible.

●Operation notes

- (1) The notes in power supply turning on.
Turn STBY pin (pin3) in the low state with power supply.
From this sequence, current flowing to the LED terminal is prevented.
- (2) Patern layout
Make wiring for power supply, GND and – GND short and thick. Take into considerations the power supply ripple.
A coupling capacitor, which lowers power supply impedance will make it decline.
- (3) Though this product is carefully checked for quality assurance, however if it exceeds the absolute maximum rating such as applied voltage and operating temperature range, this IC may be deteriorated or damaged. One this IC is damaged, short-circuits and open modes can not be identified. If the usage of the devices involves operations which will exceed the absolute maximum rating, then it is necessary to take safety measures such as a fuse to protect the device.
- (4) GND
Electric potential as the GND pin must be minimum in any operating condition. Keep the electric potential of the GND pin below that of the other pins except GND pin in consideration of transient phenomenon.
- (5) Thermal design
Be careful to ensure adequate margins for thermal design in consideration of power dissipation (Pd) in actual operating mode.
- (6) Misplacement and short-circuit between pins
When you put the IC on the print-circuit board, please be careful of the direction and correct placement of the IC.
If the IC is placed wrongly, IC may be damaged. And also, the IC may be damaged if an alien substance is mixed into the line (output-output or output-GND) to be short.

Communication ICs

(7) Operation in the strong electromagnetic field

Please be careful that this IC may be miss operated in the strong electromagnetic field.

●Electrical characteristic curves

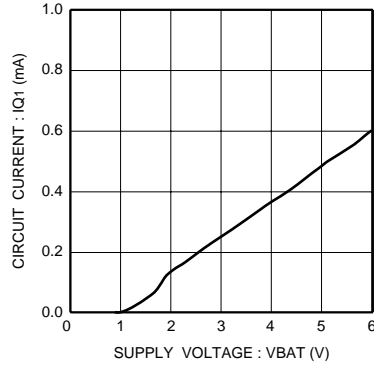

Fig.4 Circuit current-power supply voltage

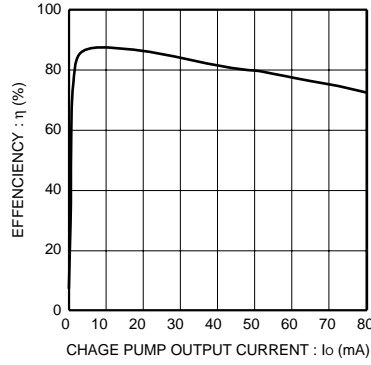

Fig.5 Efficiency-load current (note1)

note1 : Charge pump's characteristic

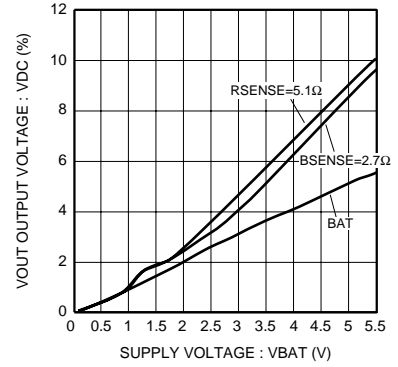

Fig.6 Charge pump output-power supply voltage

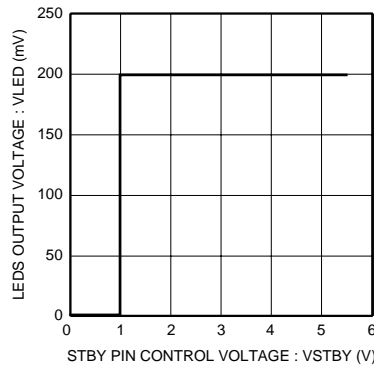

Fig.7 LEDS output voltage-STBY terminal voltage

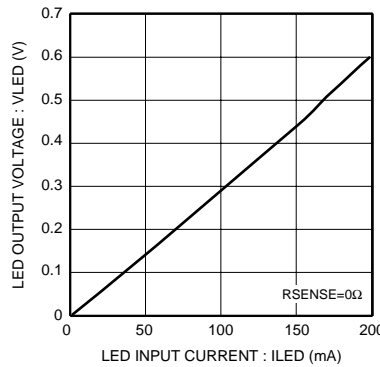

Fig.8 LED output voltage-LED power supply

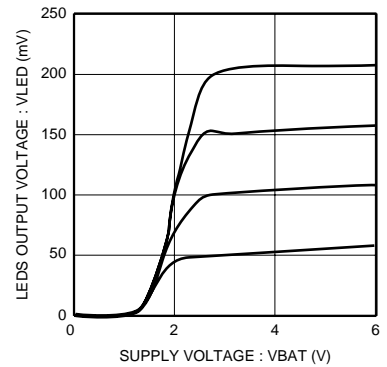
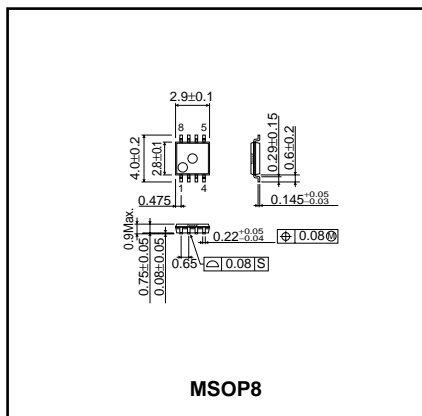

Fig.9 LEDS output voltage-power supply voltage

●External dimensions (Units: mm)





LittleDiode supplies new, hard to find or obsolete electronic components and semiconductors all over the world.

With over two million different components listed you are sure to find the part you need.

Feel free to visit us today at our online store:

LittleDiode.com

Looking forward to providing you with the best possible service.