

# 2 channel Volume IC

## BD3812F

BD3812F is a sound processor IC that has features of volume, and gain amplifier required for AV receiver and mini-component stereo. Up to 4 chips can be used with common bus line by chip select pin.

### ●Applications

AV receiver and mini stereo set.

### ●Features

- 1) Volume residual noise :  $1.2\mu$  Vrms {Dynamic range : 131dB (IHF-A)}
- 2) Volume is 2ch-independence. (0 to -103dB, MUTE 1dB / step)
- 3) BUS is common and be possible to maximum 8channel-ization of 6ch-Volume IC.
- 4) It can be controlled until 4 chips with common bus line at the same time.
- 5) Maximum output voltage :  $4.2V_{rms}$  ( $V_{CC}=7V$ ,  $V_{EE}=-7V$ ,  $R_L=10k\Omega$ )
- 6) The serial data control of 2-wire type. (correspond to 3.3V and 5V)
- 7) Built-in the convenient output gain amp.(0, 6 to 18dB, 2dB / step) for the adjustment of the output signal.
- 8) Output mute be able to serial data and external mute terminal both.

### ●External dimensions (Unit : mm)

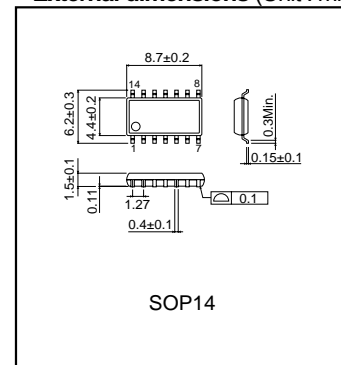

### ●Absolute maximum ratings (Ta=25°C)

Parameter	Symbol	Limits	Unit
Impressed voltage	$V_{CC}-V_{EE}$	15	V
Input voltage	$V_{IN}$	$V_{CC}+0.3$ to $V_{EE}-0.3$	V
Power dissipation	$P_d$	450 *	mW
Operating temperature	$T_{opr}$	-20 to +75	°C
Storage temperature	$T_{astg}$	-55 to +125	°C

\* This value decreases  $4.5mW/^\circ C$  for  $T_a=25^\circ C$  or more.  
A standard board,  $70 \times 70 \times 1.6mm$ , shall be mounted.

### ●Operating voltage range (Ta=25°C)

Parameter	Symbol	Min.	Typ.	Max.	Unit
Power supply (Positive)	$V_{CC}-GND$	5	-	7.3	V
Power supply (Negative)	$V_{EE}-GND$	-5	-	-7.3	V

Audio ICs

●**Electrical Characteristics** (Unless otherwise noted, Ta=25°C, Vcc=7V, VEE=-7V, f=1kHz, VIN=1Vrms, RL=10kΩ, Rg=600Ω, Master volume=0dB, Output gain=0dB)

Parameter	Symbol	Min.	Typ.	Max.	Unit	Conditions
Circuit current	$I_Q$	-	2	6	mA	No signal
Output voltage gain	$G_V$	-2	0	+2	dB	Measure : Pin13, 14
Total harmonic distortion ratio	THD	-	0.005	0.09	%	Measure : Pin13, 14, BW=400~30kHz
Maximum output voltage	Vomax	3.4	4.2	-	Vrms	Measure : Pin13, 14, THD=1%
Output noise voltage	Vno	-	1.2	5	μVrms	Measure : Pin13, 14, Rg=0Ω, BW=IHF-A
Input impedance	Rin	20	30	40	kΩ	Measure : Pin1, 3
Cross-talk between channels	CTC	-	-100	-70	dB	Measure : Pin13(OUT2), Rg=0Ω, BW=IHF-A, Reference : Pin14(OUT1)=1Vrms
Volume control range	GVR	-106	-103	-100	dB	Measure : Pin13, 14, VIN=3Vrms
Maximum attenuation	Vmin	-	-118	-105	dB	BW=IHF-A, Measure : Pin13, 14, VIN=3Vrms
Output gain control range	GOG	16	18	20	dB	Measure : Pin13, 14, VIN=0.4Vrms

●**Application circuit diagram**

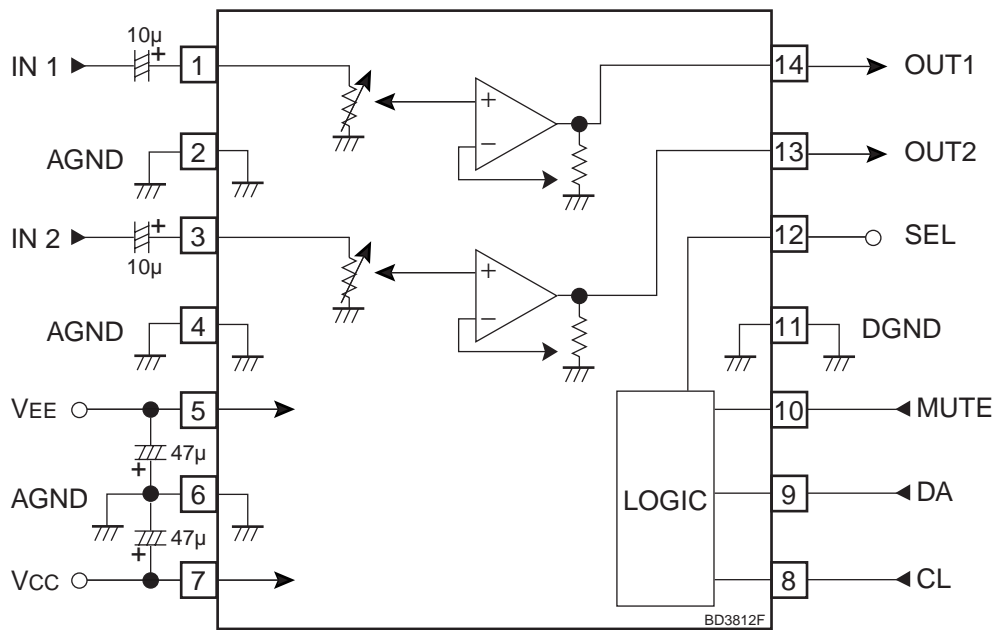

UNIT  
CAPACITOR : F

### Notes

- No technical content pages of this document may be reproduced in any form or transmitted by any means without prior permission of ROHM CO.,LTD.
- The contents described herein are subject to change without notice. The specifications for the product described in this document are for reference only. Upon actual use, therefore, please request that specifications to be separately delivered.
- Application circuit diagrams and circuit constants contained herein are shown as examples of standard use and operation. Please pay careful attention to the peripheral conditions when designing circuits and deciding upon circuit constants in the set.
- Any data, including, but not limited to application circuit diagrams information, described herein are intended only as illustrations of such devices and not as the specifications for such devices. ROHM CO.,LTD. disclaims any warranty that any use of such devices shall be free from infringement of any third party's intellectual property rights or other proprietary rights, and further, assumes no liability of whatsoever nature in the event of any such infringement, or arising from or connected with or related to the use of such devices.
- Upon the sale of any such devices, other than for buyer's right to use such devices itself, resell or otherwise dispose of the same, no express or implied right or license to practice or commercially exploit any intellectual property rights or other proprietary rights owned or controlled by
- ROHM CO., LTD. is granted to any such buyer.
- Products listed in this document are no antiradiation design.

The products listed in this document are designed to be used with ordinary electronic equipment or devices (such as audio visual equipment, office-automation equipment, communications devices, electrical appliances and electronic toys).

Should you intend to use these products with equipment or devices which require an extremely high level of reliability and the malfunction of which would directly endanger human life (such as medical instruments, transportation equipment, aerospace machinery, nuclear-reactor controllers, fuel controllers and other safety devices), please be sure to consult with our sales representative in advance.

#### About Export Control Order in Japan

Products described herein are the objects of controlled goods in Annex 1 (Item 16) of Export Trade Control Order in Japan.

In case of export from Japan, please confirm if it applies to "objective" criteria or an "informed" (by MITI clause) on the basis of "catch all controls for Non-Proliferation of Weapons of Mass Destruction.

This datasheet has been downloaded from:

[www.DatasheetCatalog.com](http://www.DatasheetCatalog.com)

Datasheets for electronic components.



LittleDiode supplies new, hard to find or obsolete electronic components and semiconductors all over the world.

With over two million different components listed you are sure to find the part you need.

Feel free to visit us today at our online store:

[LittleDiode.com](http://LittleDiode.com)

Looking forward to providing you with the best possible service.