

1.2V output

1ch Series Regulator Driver IC

BD3502FVM

● Description

The BD3502FVM is an ultra-low drop-out regulator for mobile PC. Power supply for input is separated from the power supply for a driver to supply power with lowest input voltage. Industry's first speed of transient responsivity is realized and also high-reliability is realized for digital applications with lower voltage and larger current because power supply can be composed to load current by selecting external FET.

● Dimension (Unit : mm)

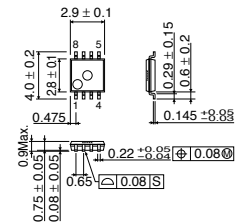

MSOP8

● Features

- 1) Rush current reduced by NRCS
- 2) Built-in driver for external Nch transistor
- 3) Built-in timer latch short protection circuit
- 4) Built-in low input error operating protection circuit
- 5) Built-in overheat protection circuit
- 6) MSOP8 package

● Applications

Power supply for mobile PC

● Absolute Maximum Ratings (Ta=25°C)

Parameter	Symbol	Limits	Unit
Input voltage	Vcc	7 *1	V
VIN voltage	VIN	7	V
Enable input voltage	Ven	7	V
Power dissipation	Pd	437.5 *2	mW
Operating temperature range	Topr	-10 ~ +100	°C
Storage temperature range	Tstg	-55 ~ +150	°C
Junction temperature	Tjmax	+150	°C

*1 Do not exceed Pd.

*2 Derating : 3.5mW/°C for operation Ta ≥ 25°C (No heat radiation board)

● Recommended Operating Conditions (Ta=25°C)

Parameter	Symbol	Min.	Typ.	Max.	Unit
Input voltage	Vcc	4.5	—	5.5	V
VIN voltage	VIN	VoX1.15	—	5.5	V
Enable input voltage	Ven	-0.3	—	5.5	V

*This product is not designed for protection against radioactive rays.

● Electrical characteristics (Unless otherwise noted: Ta=25°C, Vcc=5V, VIN=3.3V, VEN=3V)

Parameter	Symbol	Min.	Typ.	Max.	Unit	Conditions
Bias current	ICC	—	0.8	1.6	mA	
Shutdown mode current	IST	—	0	10	μA	VEN=0V
Output voltage1	Vo1	1.188	1.200	1.212	V	Io=50mA
Output voltage2	Vo2	1.164	1.200	1.236	V	Vcc=4.5V to 5.5V, Io=0A to 3A Ta=-10°C to 100°C *
<NRCS>						
NRCS charge current	Inrcs	14	20	26	μA	Vnracs=0.5V, Vcc=4.5V to 5.5V Ta=-10°C to 100°C *
<Feedback>						
VFB standby current	FBSTB	150	—	—	mA	VEN=0V, VFB=1V
<OUTPUT>						
G source current	IGSO	0.5	1	1.5	mA	VFB=Vo-0.1V, G=Vo+1V
G sink current	IGSI	2	3	4	mA	VFB=Vo+0.1V, G=Vo+1V
<UVLO>						
Vcc UVLO	VccUVLO	4.2	4.35	4.5	V	Vcc : Sweep up
Vcc UVLO hysteresis	Vcchys	100	160	220	mV	Vcc : Sweep down
VIN UVLO	VINUVLO	VoX1.05	VoX1.1	VoX1.15	V	VIN : Sweep up
VIN UVLO hysteresis	VINhys	50	100	150	mV	VIN : Sweep down
<SCP>						
SCP charge current	Iscpch	14	20	26	μA	VSCP=0.5V, Vcc=4.5V to 5.5V Ta=-10°C to 100°C *
SCP threshold voltage	Vscpth	1.2	1.3	1.4	V	VSCP=0.5V
Short detection voltage	Vscp	VoX0.6	VoX0.7	VoX0.8	V	

*Design guaranteed

● Application Circuit

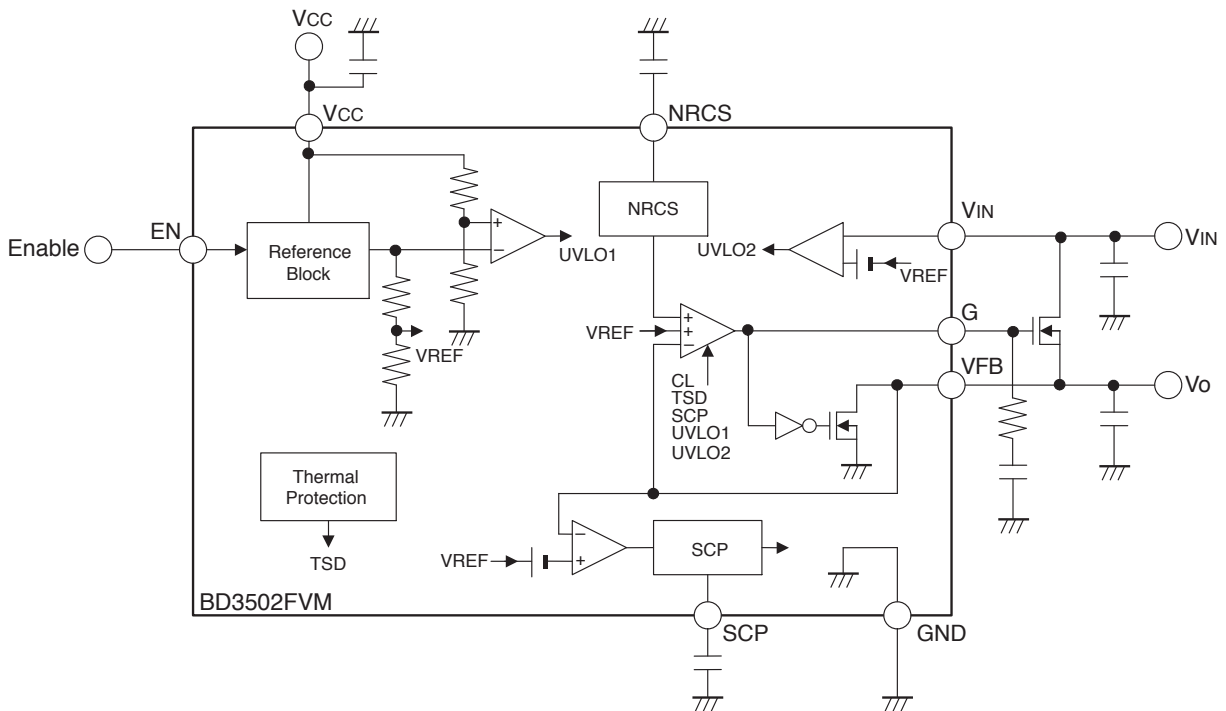



LittleDiode supplies new, hard to find or obsolete electronic components and semiconductors all over the world.

With over two million different components listed you are sure to find the part you need.

Feel free to visit us today at our online store:

LittleDiode.com

Looking forward to providing you with the best possible service.