

## PNP Silicon AF Transistors

**BCW 67**  
**BCW 68**

- For general AF applications
- High current gain
- Low collector-emitter saturation voltage
- Complementary types: BCW 65, BCW 66 (NPN)

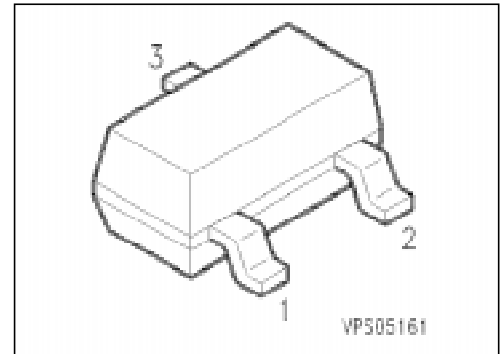

Type	Marking	Ordering Code (tape and reel)	Pin Configuration			Package <sup>1)</sup>
			1	2	3	
BCW 67 A	DAs	Q62702-C1560	B	E	C	SOT-23
BCW 67 B	DBs	Q62702-C1480				
BCW 67 C	DCs	Q62702-C1681				
BCW 68 F	DFs	Q62702-C1893				
BCW 68 G	DGs	Q62702-C1322				
BCW 68 H	DHs	Q62702-C1555				

<sup>1)</sup> For detailed information see chapter Package Outlines.

## Maximum Ratings

Parameter	Symbol	Values		Unit
		BCW 67	BCW 68	
Collector-emitter voltage	$V_{CE0}$	32	45	V
Collector-base voltage	$V_{CB0}$	45	60	
Emitter-base voltage	$V_{EB0}$	5	5	
Collector current	$I_C$	800		mA
Peak collector current	$I_{CM}$	1		A
Base current	$I_B$	100		mA
Peak base current	$I_{BM}$	200		
Total power dissipation, $T_s = 79\text{ °C}$	$P_{tot}$	330		mW
Junction temperature	$T_j$	150		°C
Storage temperature range	$T_{stg}$	- 65 ... + 150		

## Thermal Resistance

Junction - ambient <sup>1)</sup>	$R_{th JA}$	≤ 285	K/W
Junction - soldering point	$R_{th JS}$	≤ 215	

<sup>1)</sup> Package mounted on epoxy pcb 40 mm × 40 mm × 1.5 mm/6 cm<sup>2</sup> Cu.

## Electrical Characteristics

at  $T_A = 25\text{ °C}$ , unless otherwise specified.

Parameter	Symbol	Values			Unit
		min.	typ.	max.	

### DC characteristics

Collector-emitter breakdown voltage $I_C = 10\text{ mA}$	$V_{(BR)CE0}$				V
BCW 67		32	—	—	
BCW 68		45	—	—	
Collector-base breakdown voltage $I_C = 10\text{ }\mu\text{A}$	$V_{(BR)CB0}$				
BCW 67		45	—	—	
BCW 68		60	—	—	
Emitter-base breakdown voltage, $I_E = 10\text{ }\mu\text{A}$	$V_{(BR)EB0}$	5	—	—	
Collector cutoff current $V_{CB} = 32\text{ V}$	$I_{CB0}$				nA
BCW 67		—	—	20	
$V_{CB} = 45\text{ V}$					nA
BCW 68		—	—	20	
$V_{CB} = 32\text{ V}, T_A = 150\text{ °C}$					$\mu\text{A}$
BCW 67		—	—	20	
$V_{CB} = 45\text{ V}, T_A = 150\text{ °C}$					$\mu\text{A}$
BCW 68		—	—	20	
Emitter-base cutoff current, $V_{EB} = 4\text{ V}$	$I_{EB0}$	—	—	20	nA
DC current gain <sup>1)</sup> $I_C = 100\text{ }\mu\text{A}, V_{CE} = 10\text{ V}$	$h_{FE}$				—
BCW 67 A, BCW 68 F		35	—	—	
BCW 67 B, BCW 68 G		50	—	—	
BCW 67 C, BCW 68 H		80	—	—	
$I_C = 10\text{ mA}, V_{CE} = 1\text{ V}$					
BCW 67 A, BCW 68 F		75	—	—	
BCW 67 B, BCW 68 G		120	—	—	
BCW 67 C, BCW 68 H		180	—	—	
$I_C = 100\text{ mA}, V_{CE} = 1\text{ V}$					
BCW 67 A, BCW 68 F		100	160	250	
BCW 67 B, BCW 68 G		160	250	400	
BCW 67 C, BCW 68 H		250	350	630	
$I_C = 500\text{ mA}, V_{CE} = 2\text{ V}$					
BCW 67 A, BCW 68 F		35	—	—	
BCW 67 B, BCW 68 G		60	—	—	
BCW 67 C, BCW 68 H		100	—	—	

<sup>1)</sup> Pulse test:  $t \leq 300\text{ }\mu\text{s}, D = 2\%$ .

## Electrical Characteristics

at  $T_A = 25\text{ °C}$ , unless otherwise specified.

Parameter	Symbol	Values			Unit
		min.	typ.	max.	

### DC characteristics

Collector-emitter saturation voltage <sup>1)</sup> $I_C = 100\text{ mA}$ , $I_B = 10\text{ mA}$ $I_C = 500\text{ mA}$ , $I_B = 50\text{ mA}$	$V_{CEsat}$	–	–	0.3 0.7	V
Base-emitter saturation voltage <sup>1)</sup> $I_C = 100\text{ mA}$ , $I_B = 10\text{ mA}$ $I_C = 500\text{ mA}$ , $I_B = 50\text{ mA}$	$V_{BEsat}$	–	–	1.25 2	

### AC characteristics

Transition frequency $I_C = 50\text{ mA}$ , $V_{CE} = 5\text{ V}$ , $f = 20\text{ MHz}$	$f_t$	–	200	–	MHz
Output capacitance $V_{CB} = 10\text{ V}$ , $f = 1\text{ MHz}$	$C_{obo}$	–	6	–	pF
Input capacitance $V_{EB} = 0.5\text{ V}$ , $f = 1\text{ MHz}$	$C_{ibo}$	–	60	–	

<sup>1)</sup> Pulse test:  $t \leq 300\text{ }\mu\text{s}$ ,  $D = 2\text{ %}$ .

### Total power dissipation $P_{tot} = f(T_A^*; T_S)$

\* Package mounted on epoxy

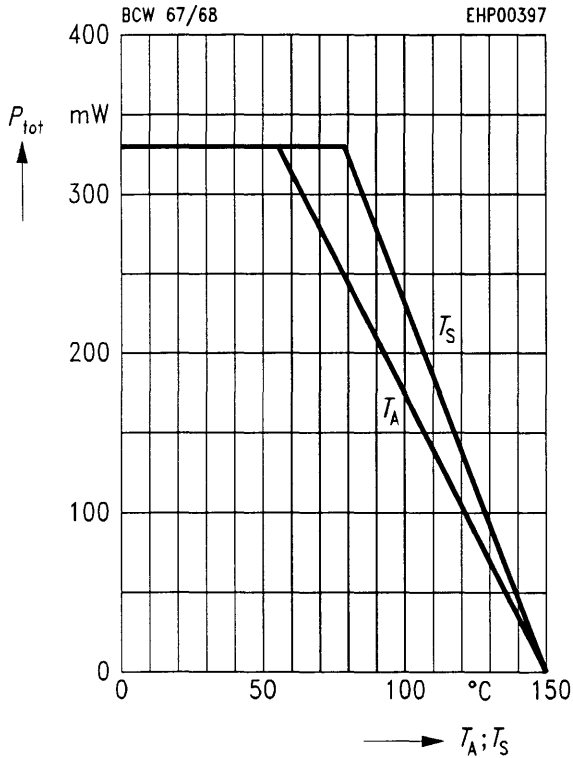

### Transition frequency $f_T = f(I_C)$

$V_{CE} = 5 V$

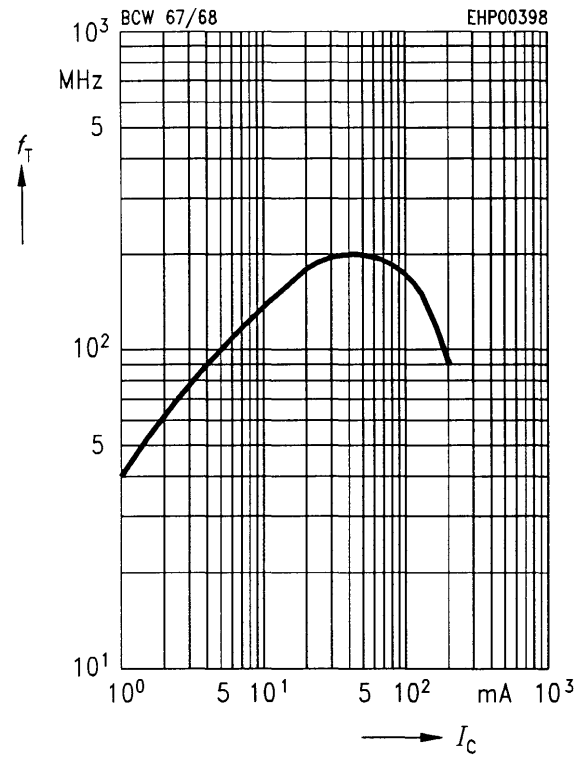

### Permissible pulse load $P_{tot max}/P_{tot DC} = f(t_p)$

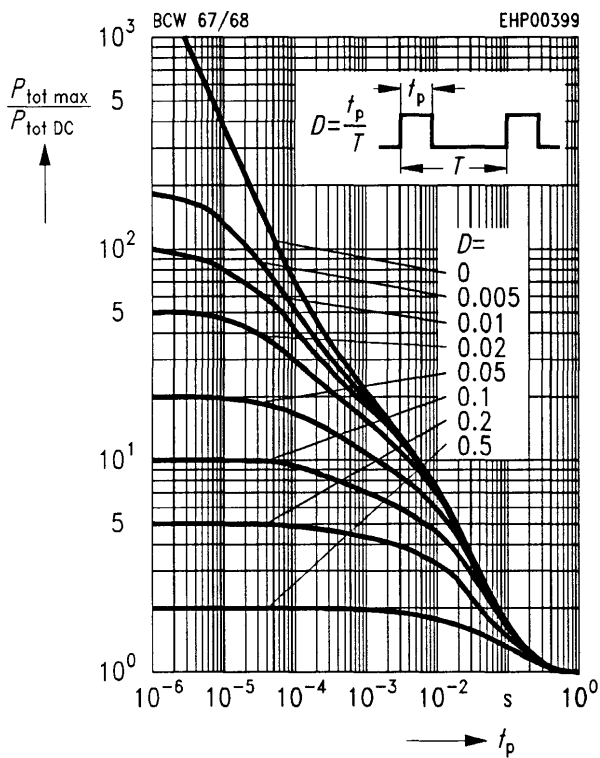

### Collector cutoff current $I_{CB0} = f(T_A)$

$V_{CB} = V_{CEmax}$

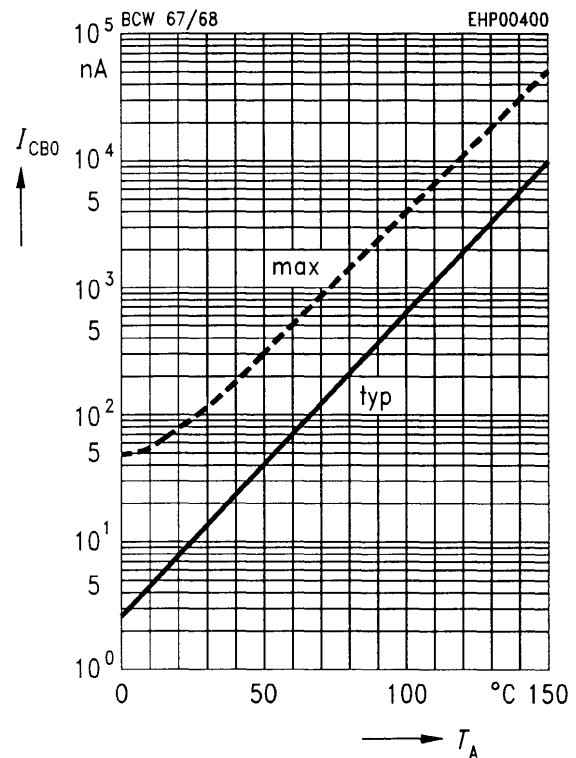

**Base-emitter saturation voltage**

$I_C = f(V_{BEsat})$

$h_{FE} = 10$

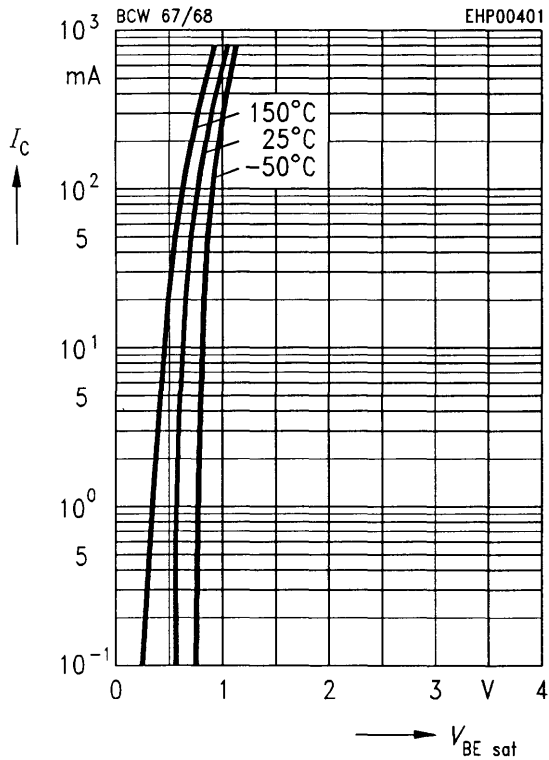

**Collector-emitter saturation voltage**

$I_C = f(V_{CEsat})$

$h_{FE} = 10$

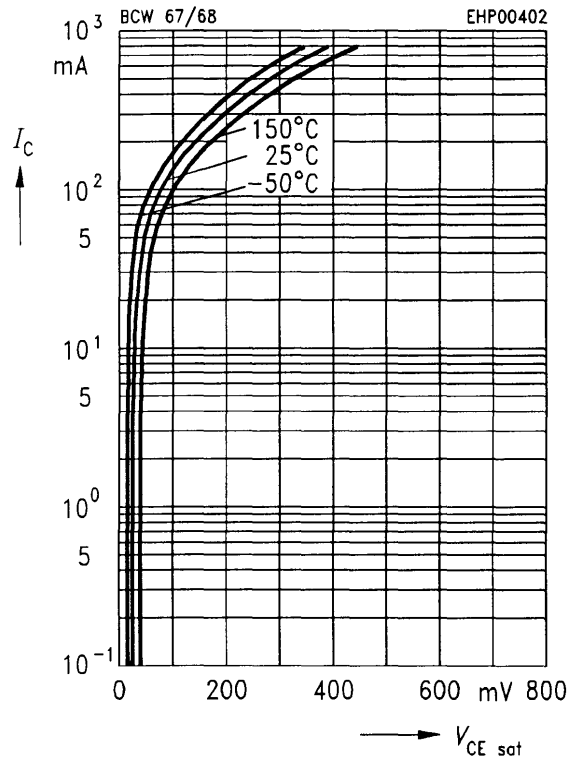

**DC current gain  $h_{FE} = f(I_C)$**

$V_{CE} = 1 V$

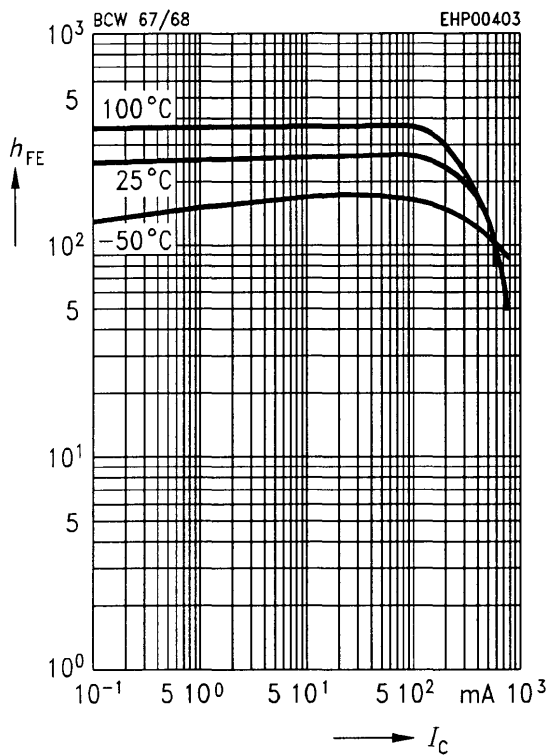



LittleDiode supplies new, hard to find or obsolete electronic components and semiconductors all over the world.

With over two million different components listed you are sure to find the part you need.

Feel free to visit us today at our online store:

[LittleDiode.com](http://LittleDiode.com)

Looking forward to providing you with the best possible service.