

SOT23 NPN SILICON PLANAR SMALL SIGNAL TRANSISTORS

BCW60

ISSUE 2 – AUGUST 1995

PARTMARKING DETAILS

BCW60A – AA	BCW60AR – CR
BCW60B – AB	BCW60BR – DR
BCW60C – AC	BCW60CR – AR
BCW60D – AD	BCW60DR – BR

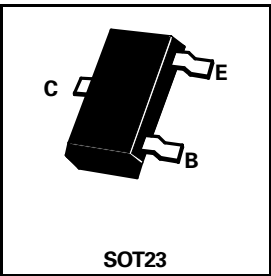

COMPLEMENTARY TYPE

BCW61

ABSOLUTE MAXIMUM RATINGS.

PARAMETER	SYMBOL	VALUE	UNIT
Collector-Base Voltage	V_{CBO}	32	V
Collector-Emitter Voltage	V_{CEO}	32	V
Emitter-Base Voltage	V_{EBO}	5	V
Continuous Collector Current	I_C	200	mA
Base Current	I_B	50	mA
Power Dissipation at $T_{amb}=25^{\circ}C$	P_{TOT}	330	mW
Operating and Storage Temperature Range	tj:tstg	-55 to +150	$^{\circ}C$

FOUR TERMINAL NETWORK DATA ($I_C=2mA$, $V_{CE}=5V$, $f=1kHz$)

	h_{FE} Group A			h_{FE} Group B			h_{FE} Group C			h_{FE} Group D			
	Min.	Typ.	Max.	Min.	Typ.	Max.	Min.	Typ.	Max.	Min.	Typ.	Max.	
h_{11e}	1.6	2.7	4.5	2.5	3.6	6.0	3.2	4.5	8.5	4.5	7.5	12	$k\Omega$
h_{12e}		1.5			2			2			3		10^{-4}
h_{21e}		200			260			330			520		
h_{22e}		18	30		24	50		30	60		50	100	μS

SWITCHING CIRCUIT

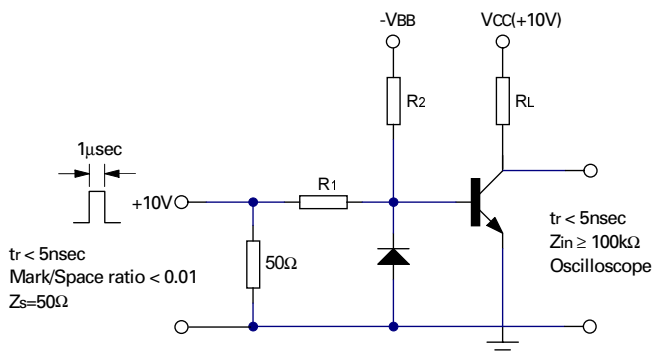

BCW60

ELECTRICAL CHARACTERISTICS (at $T_{amb} = 25^{\circ}\text{C}$ unless otherwise stated).

PARAMETER	SYMBOL	MIN.	TYP.	MAX.	UNIT	CONDITIONS.
Collector-Emitter Breakdown Voltage	$V_{(BR)CEO}$	32			V	$I_C=2\text{mA}$
Emitter-Base Breakdown Voltage	$V_{(BR)EBO}$	5			V	$I_{EBO}=1\mu\text{A}$
Collector-Emitter Cut-off Current	I_{CES}			20 20	nA μA	$V_{CES}=32\text{V}$ $V_{CES}=32\text{V}, T_{amb}=150^{\circ}\text{C}$
Emitter-Base Cut-Off Current	I_{EBO}			20	nA	$V_{EBO}=4\text{V}$
Collector-Emitter Saturation Voltage	$V_{CE(sat)}$		0.12 0.20	0.35 0.55	V V	$I_C=10\text{mA}, I_B=0.25\text{mA}$ $I_C=50\text{mA}, I_B=1.25\text{mA}$
Base-Emitter Saturation Voltage	$V_{BE(SAT)}$	0.60 0.70	0.70 0.83	0.85 1.05	V V	$I_C=10\text{mA}, I_B=0.25\text{mA}$ $I_C=50\text{mA}, I_B=1.25\text{mA}$
Base - Emitter Voltage	V_{BE}	0.55	0.52 0.65 0.78	0.75	V V V	$I_C=10\mu\text{A}, V_{CE}=5\text{V}$ $I_C=2\text{mA}, V_{CE}=5\text{V}$ $I_C=50\text{mA}, V_{CE}=1\text{V}$
Static BCW60A Forward Current Ratio	h_{FE}	120 50	78 170	220		$I_C=10\mu\text{A}, V_{CE}=5\text{V}$ $I_C=2\text{mA}, V_{CE}=5\text{V}$ $I_C=50\text{mA}, V_{CE}=1\text{V}$
BCW60B			20 180 70			145 250
BCW60C		40 250 90	220 350	460		$I_C=10\mu\text{A}, V_{CE}=5\text{V}$ $I_C=2\text{mA}, V_{CE}=5\text{V}$ $I_C=50\text{mA}, V_{CE}=1\text{V}$
BCW60D		100 380 100	300 500	630		$I_C=10\mu\text{A}, V_{CE}=5\text{V}$ $I_C=2\text{mA}, V_{CE}=5\text{V}$ $I_C=50\text{mA}, V_{CE}=1\text{V}$
Transition Frequency	f_T	125	250		MHz	$I_C=10\text{mA}, V_{CE}=5\text{V}$ $f=100\text{MHz}$
Emitter-Base Capacitance	C_{ebo}		8		pF	$V_{EBO}=0.5\text{V}, f=1\text{MHz}$
Collector-Base Capacitance	C_{cbo}			4.5	pF	$V_{CBO}=10\text{V}, f=1\text{MHz}$
Noise Figure	N		2	6	dB	$I_C=0.2\text{mA}, V_{CE}=5\text{V}$ $R_G=2\text{K}\Omega, f=1\text{KH}$ $\Delta f=200\text{Hz}$
Switching times: Delay Time Rise Time Turn-on Time Storage Time Fall Time Turn-Off Time	t_d t_r t_{on} t_s t_f t_{off}		35 50 85 400 80 480	150	ns ns ns ns ns ns	$I_{C1}:I_{B1}:I_{B2}=10:1:1\text{mA}$ $R_1=5\text{K}\Omega, R_2=5\text{K}\Omega$ $V_{BB}=3.6\text{V}, R_L=990\Omega$

*Measured under pulsed conditions. Pulse width=300 μs . Duty cycle
 Spice parameter data is available upon request for this device



LittleDiode supplies new, hard to find or obsolete electronic components and semiconductors all over the world.

With over two million different components listed you are sure to find the part you need.

Feel free to visit us today at our online store:

LittleDiode.com

Looking forward to providing you with the best possible service.