

### Surface Mount Triac 5 Amperes/400-600 Volts

#### OUTLINE DRAWING

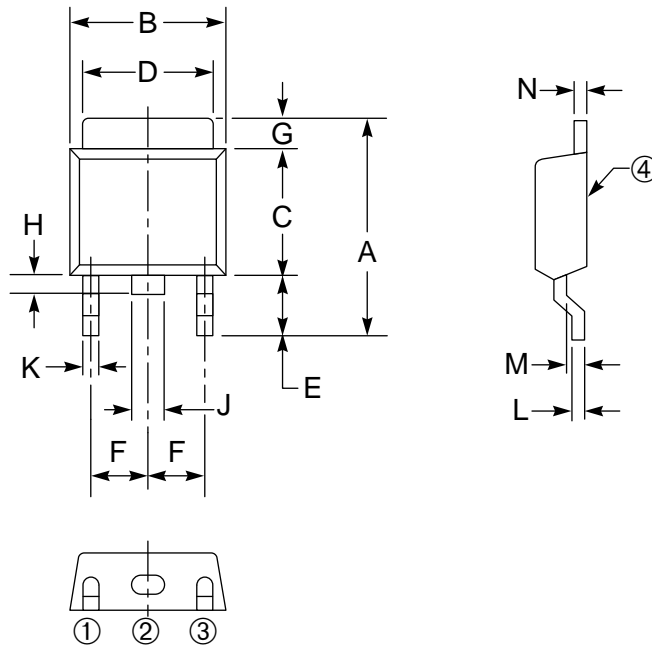

#### CONNECTION DIAGRAM

- ① T1 TERMINAL
- ② T2 TERMINAL
- ③ GATE TERMINAL
- ④ T2 TERMINAL

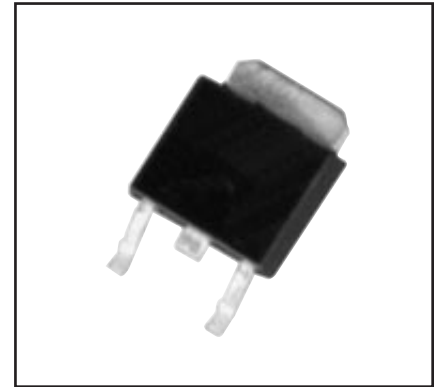
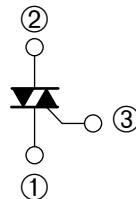

#### Description:

A triac is a solid state silicon AC switch which may be gate triggered from an off-state to an on-state for either polarity of applied voltage.

#### Features:

- Surface Mount Type
- Glass Passivation
- Selected for Inductive Loads

#### Applications:

- AC Switch
- Heating
- Motor Controls
- Lighting

#### Ordering Information:

Example: Select the complete eight or nine digit part number you desire from the table - i.e. BCR5AS-8L is a 400 Volt, 5 Ampere Triac.

Outline Drawing (Conforms to MP-3)

Dimensions	Inches	Millimeters
A	0.39 Max.	10 Max.
B	0.26	6.5
C	0.22 ± 0.008	5.5 ± 0.2
D	0.20 ± 0.008	5.0 ± 0.2
E	0.9 Min.	2.3 Min.
F	0.9	2.3
G	0.06 ± 0.008	1.5 ± 0.2

Dimensions	Inches	Millimeters
H	0.040 Min.	1.0 Min.
J	0.040	1.0
K	0.4 Max.	0.9 Max.
L	0.03	0.8
M	0.020 ± 0.01	0.5 ± 0.2
N	0.020	0.5 ± 0.1

Type	V <sub>DRM</sub> Volts	Code	Inductive Load
BCR5AS	400 600	-8 -12	L



Powerex, Inc., 200 Hillis Street, Youngwood, Pennsylvania 15697-1800 (412) 925-7272

**BCR5AS**  
**Surface Mount Triac**  
5 Amperes/400-600 Volts

**Absolute Maximum Ratings,  $T_a = 25\text{ }^\circ\text{C}$  unless otherwise specified**

Ratings	Symbol	BCR5AS-8L	BCR5AS-12L	Units
Repetitive Peak Off-state Voltage	$V_{DRM}$	400	600	Volts
Non-repetitive Peak Off-state Voltage	$V_{DSM}$	500	720	Volts
On-state Current, $T_c = 103^\circ\text{C}$	$I_{T(RMS)}$	5	5	Amperes
Non-repetitive Peak Surge, One Cycle (60 Hz)	$I_{TSM}$	50	50	Amperes
$I^2t$ for Fusing, $t = 8.3\text{ msec}$	$I^2t$	10.4	10.4	$\text{A}^2\text{sec}$
Peak Gate Power Dissipation, 20 $\mu\text{sec}$	$P_{GM}$	3	3	Watts
Average Gate Power Dissipation	$P_{G(avg)}$	0.3	0.3	Watts
Peak Gate Current	$I_{GM}$	2	2	Amperes
Peak Gate Voltage	$V_{GM}$	10	10	Volts
Storage Temperature	$T_{stg}$	-40 to 125	-40 to 125	$^\circ\text{C}$
Operating Temperature	$T_j$	-40 to 125	-40 to 125	$^\circ\text{C}$
Weight	–	0.26	0.26	mg



Powerex, Inc., 200 Hillis Street, Youngwood, Pennsylvania 15697-1800 (412) 925-7272

**BCR5AS**  
**Surface Mount Triac**  
 5 Amperes/400-600 Volts

**Electrical and Thermal Characteristics,  $T_j = 25\text{ }^\circ\text{C}$  unless otherwise specified**

Characteristics	Symbol	Test Conditions (Trigger Mode)				BCR5AS			Units
		$V_D$	$R_L$	$R_G$	$T_j$	Min.	Typ.	Max.	
Gate Parameters									
DC Gate Trigger Current									
MT2+ Gate+	$I_{GT}$	6V	6 $\Omega$	330 $\Omega$	25 $^\circ\text{C}$	–	–	30	mA
MT2+ Gate–		6V	6 $\Omega$	330 $\Omega$	25 $^\circ\text{C}$	–	–	30	mA
MT2– Gate–		6V	6 $\Omega$	330 $\Omega$	25 $^\circ\text{C}$	–	–	30	mA
DC Gate Trigger Voltage									
MT2+ Gate+	$V_{GT}$	6V	6 $\Omega$	330 $\Omega$	25 $^\circ\text{C}$	–	–	1.5	Volts
MT2+ Gate–		6V	6 $\Omega$	330 $\Omega$	25 $^\circ\text{C}$	–	–	1.5	Volts
MT2– Gate–		6V	6 $\Omega$	330 $\Omega$	25 $^\circ\text{C}$	–	–	1.5	Volts
DC Gate Non-trigger Voltage									
All	$V_{GD}$	1/2 V	–	–	125 $^\circ\text{C}$	0.2	–	–	Volts

**BCR5AS**  
**Surface Mount Triac**  
 5 Amperes/400-600 Volts

**Electrical and Thermal Characteristics,  $T_j = 25^\circ\text{C}$  unless otherwise specified**

Characteristics	Symbol	Test Conditions	Min.	Typ.	Max.	Units
Thermal Resistance, Junction-to-case	$R_{th(j-c)}$	–	–	–	3.0	$^\circ\text{C/W}$
Voltage – Blocking State Repetitive Off-state Current	$I_{DRM}$	$V_{DRM}$ = Maximum Allowable Repetitive Off-state Voltage Rating, Gate Open Circuited, $T_j = 125^\circ\text{C}$	–	–	2.0	mA
Current – Conducting State Peak On-state Current	$V_{TM}$	$T_C = 25^\circ\text{C}$ , 8.3ms Pulsewidth Duty Cycle < 2%, $I_{TM} = 7\text{A}$	–	–	1.8	Volts
Critical Rate-of-rise of Commutating Off-state Voltage (Commutating $dv/dt$ ) ▲ for Inductive Load (Switching)	$(dv/dt)_C$	–	–	–	–	$\text{V}/\mu\text{s}$

$\Delta$ Part Number	$V_{DRM}$ (Volts)	Commutating $dv/dt, (dv/dt)_C$ ( $\text{V}/\mu\text{sec}$ )		Test Condition	Commutating Voltage & Current Waveform (Inductive Load)
		Load Type	Minimum		
BCR5AS-8L	400	L	5	$T_j = 125^\circ\text{C}$ , Rate of Decay On-state Commutating Current $(di/dt)_C = -2.5\text{A/msec}$ ; Peak Off-state Voltage $V_D = 400\text{V}$	
BCR5AS-12L	600	L	5		

**BCR5AS**  
**Surface Mount Triac**  
 5 Amperes/400-600 Volts

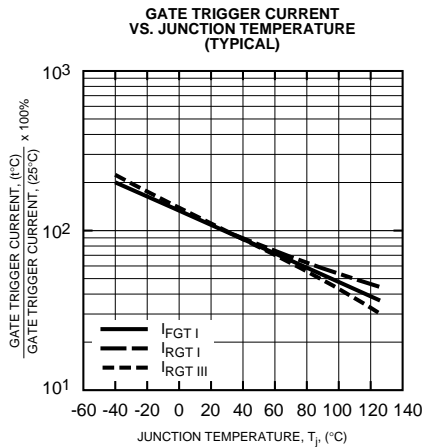
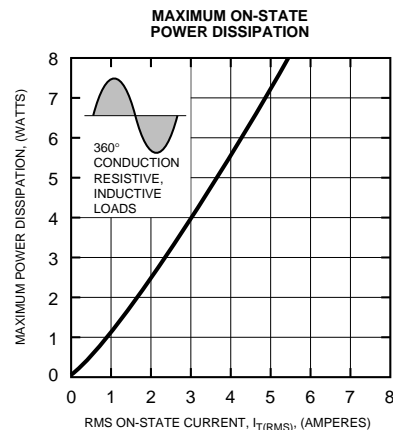
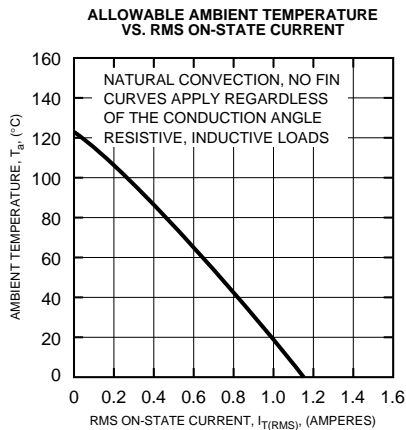
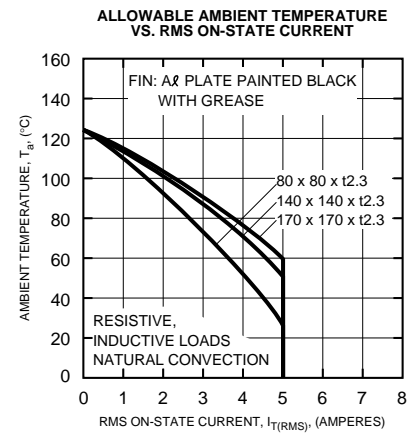
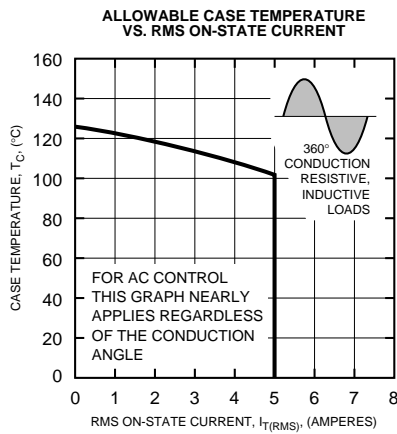
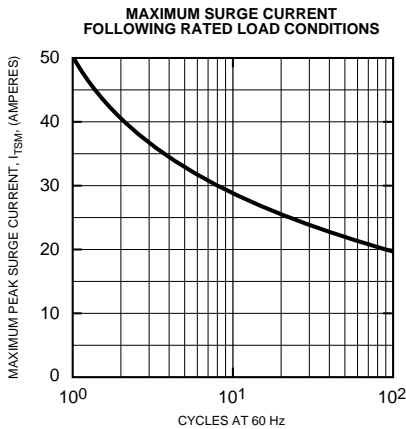
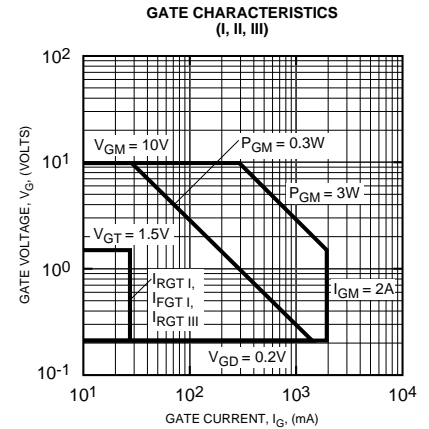
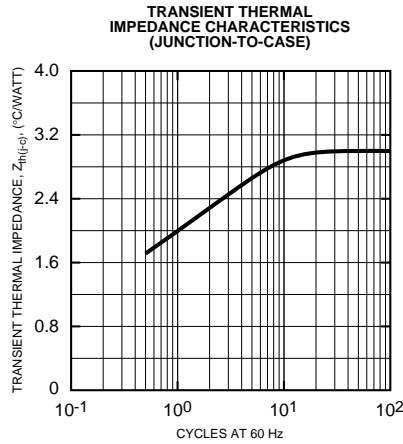
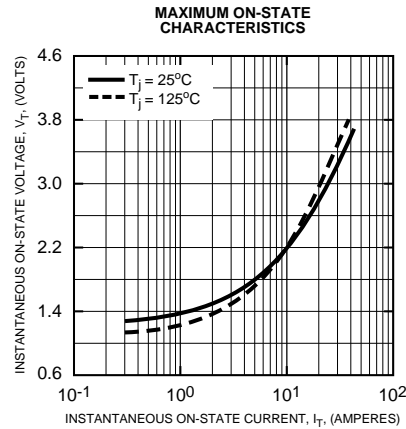

**BCR5AS**  
**Surface Mount Triac**  
 5 Amperes/400-600 Volts

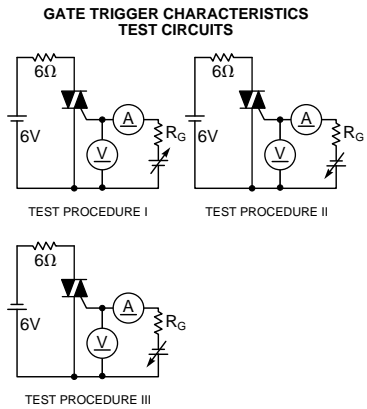
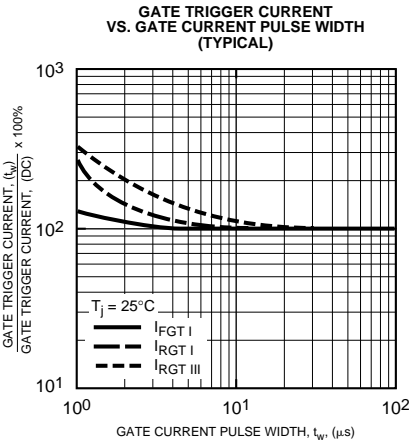
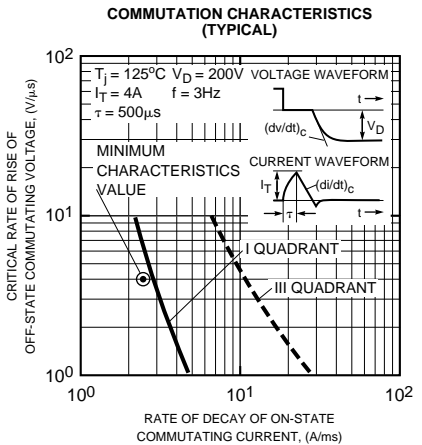
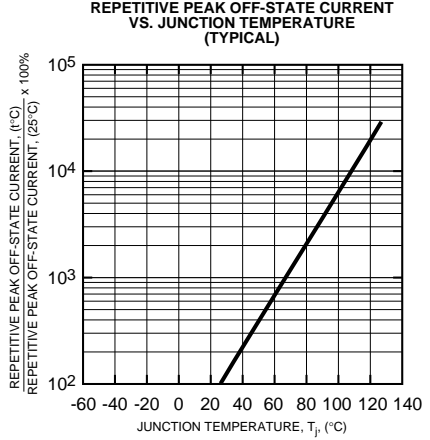
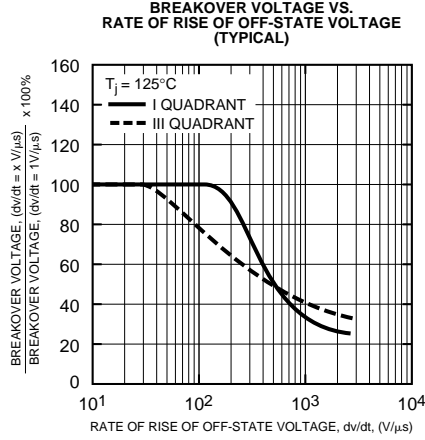
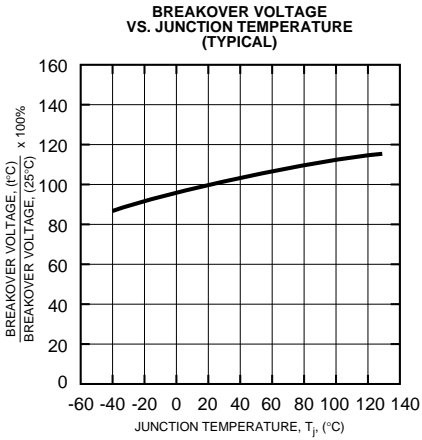
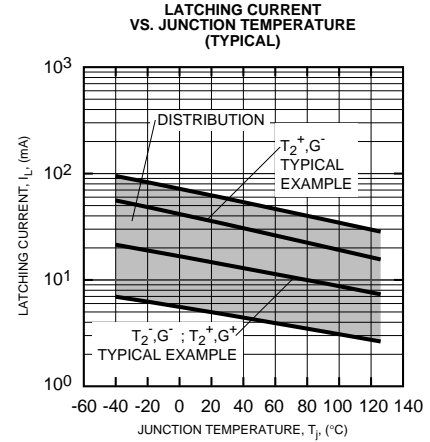
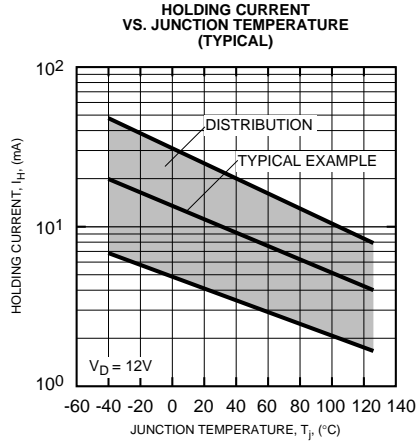
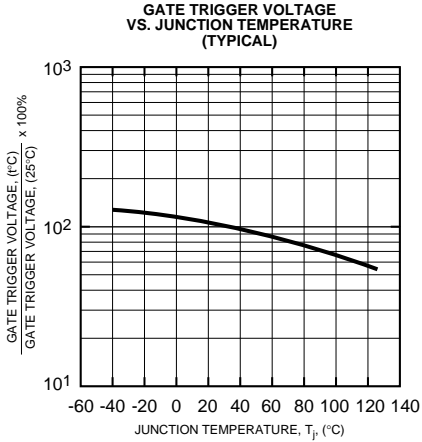

This datasheet has been downloaded from:

[www.DatasheetCatalog.com](http://www.DatasheetCatalog.com)

Datasheets for electronic components.



LittleDiode supplies new, hard to find or obsolete electronic components and semiconductors all over the world.

With over two million different components listed you are sure to find the part you need.

Feel free to visit us today at our online store:

[LittleDiode.com](http://LittleDiode.com)

Looking forward to providing you with the best possible service.