

MITSUBISHI SEMICONDUCTOR (TRIAC)  
**BCR25A, BCR25B**

MEDIUM POWER USE  
 NON-INSULATED TYPE, GLASS PASSIVATION TYPE

BCR25A, BCR25B



- $I_T$  (RMS) ..... 25A
- $V_{DRM}$  ..... 400V/500V
- IFGT I , IRGT II ..... 50mA
- IRGT I ..... 75mA

**APPLICATION**

Contactless AC switches, light dimmer,  
 on/off control of copier lamps

OUTLINE DRAWING

Dimensions  
 in mm

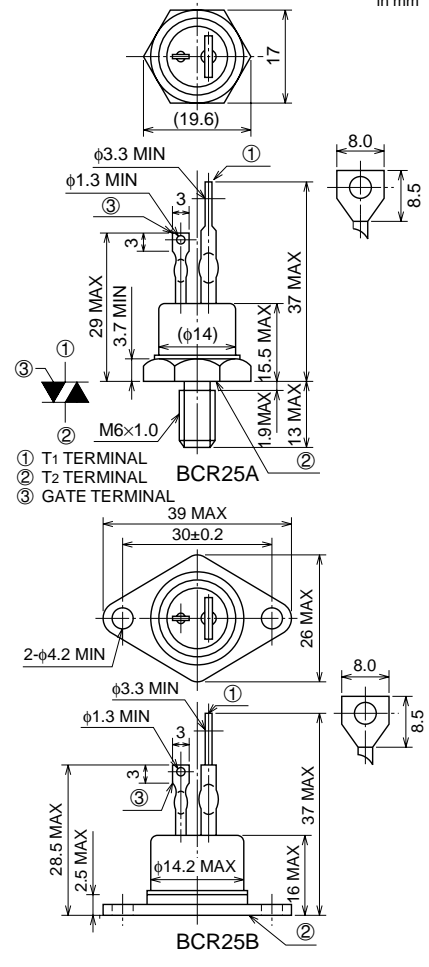

**MAXIMUM RATINGS**

Symbol	Parameter	Voltage class		Unit
		8	10	
$V_{DRM}$	Repetitive peak off-state voltage*1	400	500	V
$V_{DSM}$	Non-repetitive peak off-state voltage*1	600	600	V

Symbol	Parameter	Conditions	Ratings	Unit
$I_T$ (RMS)	RMS on-state current	Commercial frequency, sine full wave, 360° conduction, $T_c=92^\circ\text{C}$	25	A
$I_{TSM}$	Surge on-state current	60Hz sinewave 1 full cycle, peak value, non-repetitive	250	A
$I^2t$	$I^2t$ for fusing	Value corresponding to 1 cycle of half wave 60Hz, surge on-state current	262	A <sup>2</sup> s
PGM	Peak gate power dissipation		5.0	W
PG (AV)	Average gate power dissipation		0.5	W
VGM	Peak gate voltage		10	V
IGM	Peak gate current		2.0	A
$T_j$	Junction temperature		-20 ~ +125	°C
$T_{stg}$	Storage temperature		-20 ~ +125	°C
—	Mounting torque	BCR25A only	30	kg-cm
			2.94	N-m
—	Weight	BCR25A (Typical value)	18	g
		BCR25B (Typical value)	23	

\*1. Gate open.

# BCR25A, BCR25B

MEDIUM POWER USE

NON-INSULATED TYPE, GLASS PASSIVATION TYPE

## ELECTRICAL CHARACTERISTICS

Symbol	Parameter	Test conditions	Limits			Unit	
			Min.	Typ.	Max.		
IDRM	Repetitive peak off-state current	T <sub>j</sub> =125°C, V <sub>DRM</sub> applied	—	—	5.0	mA	
VTM	On-state voltage	T <sub>c</sub> =25°C, I <sub>TM</sub> =40A, Instantaneous measurement	—	—	1.6	V	
VFGT I	Gate trigger voltage *2	T <sub>j</sub> =25°C, V <sub>D</sub> =6V, R <sub>L</sub> =6Ω, R <sub>G</sub> =330Ω	I	—	—	3.0	V
VRGT I			II	—	—	3.0	V
VRGT III			III	—	—	3.0	V
IFGT I	Gate trigger current *2	T <sub>j</sub> =25°C, V <sub>D</sub> =6V, R <sub>L</sub> =6Ω, R <sub>G</sub> =330Ω	I	—	—	50	mA
IRGT I			II	—	—	75	mA
IRGT III			III	—	—	50	mA
VGD	Gate non-trigger voltage	T <sub>j</sub> =125°C, V <sub>D</sub> =1/2V <sub>DRM</sub>	0.2	—	—	V	
R <sub>th(j-c)</sub>	Thermal resistance	Junction to case	—	—	1.0	°C/W	
(dv/dt) <sub>c</sub>	Critical-rate of rise of off-state commutating voltage		*3	—	—	V/μs	

\*2. Measurement using the gate trigger characteristics measurement circuit.

\*3. The critical-rate of rise of the off-state commutating voltage is shown in the table below.

Voltage class	V <sub>DRM</sub> (V)	(dv/dt) <sub>c</sub>			Test conditions	Commutating voltage and current waveforms (inductive load)
		Symbol	Min.	Unit		
8	400	R	—	V/μs	1. Junction temperature T <sub>j</sub> =125°C 2. Rate of decay of on-state commutating current (di/dt) <sub>c</sub> =-13.5A/ms 3. Peak off-state voltage V <sub>D</sub> =400V	
		L	20			
10	500	R	—			
		L	20			

## PERFORMANCE CURVES

MAXIMUM ON-STATE CHARACTERISTICS

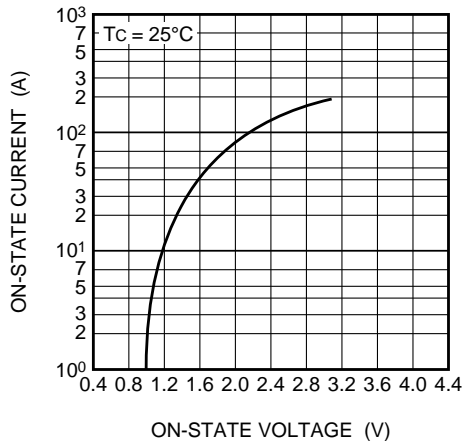

RATED SURGE ON-STATE CURRENT

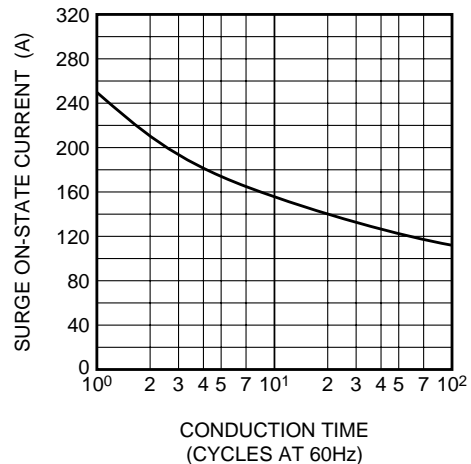

# BCR25A, BCR25B

MEDIUM POWER USE

NON-INSULATED TYPE, GLASS PASSIVATION TYPE

**GATE CHARACTERISTICS**

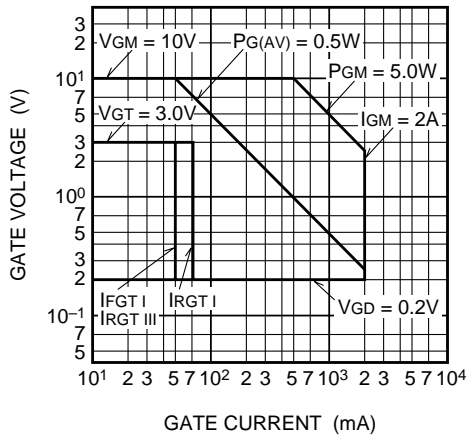

**GATE TRIGGER CURRENT-VOLTAGE VS. JUNCTION TEMPERATURE**

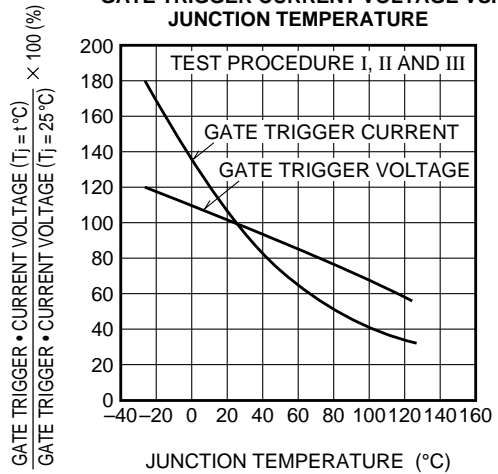

**MAXIMUM TRANSIENT THERMAL IMPEDANCE CHARACTERISTICS (JUNCTION TO CASE)**

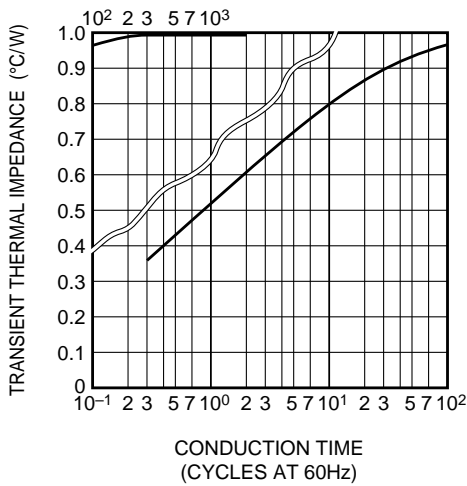

**MAXIMUM ON-STATE POWER DISSIPATION**

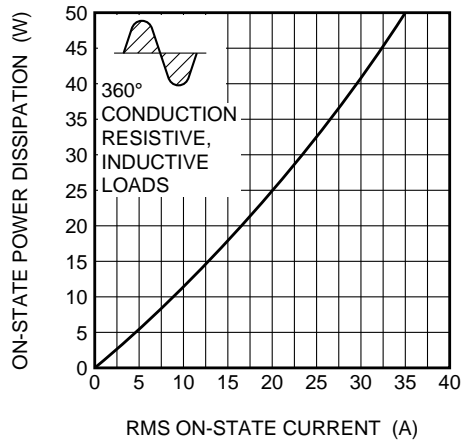

**ALLOWABLE CASE TEMPERATURE VS. RMS ON-STATE CURRENT**

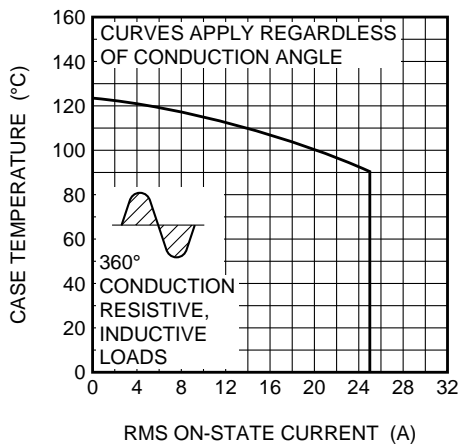

**ALLOWABLE AMBIENT TEMPERATURE VS. RMS ON-STATE CURRENT (BCR25A)**

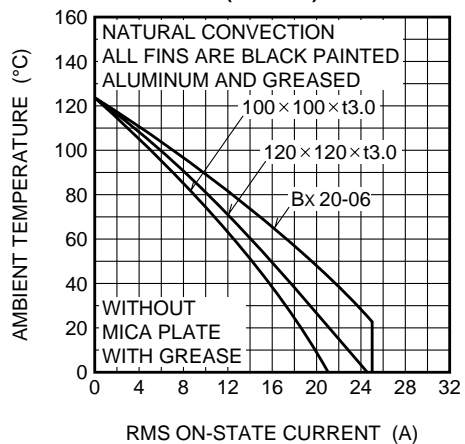

# BCR25A, BCR25B

MEDIUM POWER USE  
NON-INSULATED TYPE, GLASS PASSIVATION TYPE

**ALLOWABLE AMBIENT TEMPERATURE  
VS. RMS ON-STATE CURRENT  
(BCR25B)**

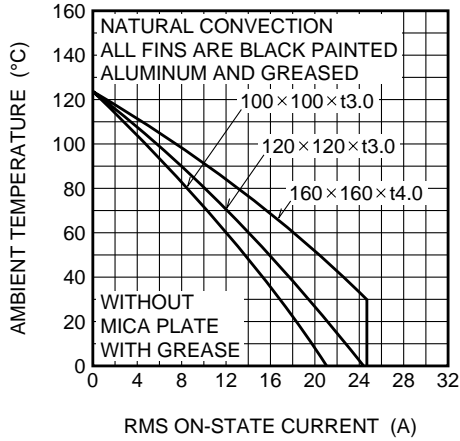

**BREAKOVER VOLTAGE VS.  
JUNCTION TEMPERATURE**

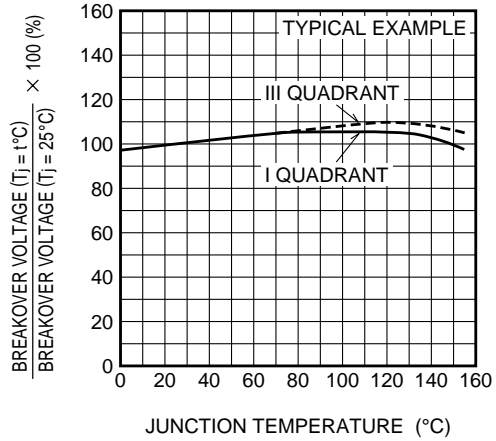

**COMMUTATION CHARACTERISTICS**

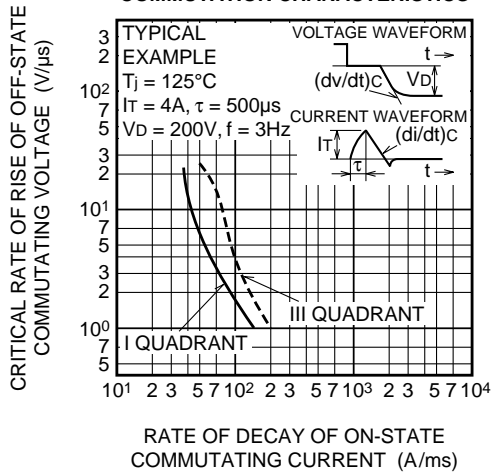

**GATE TRIGGER CURRENT VS.  
GATE CURRENT PULSE WIDTH**

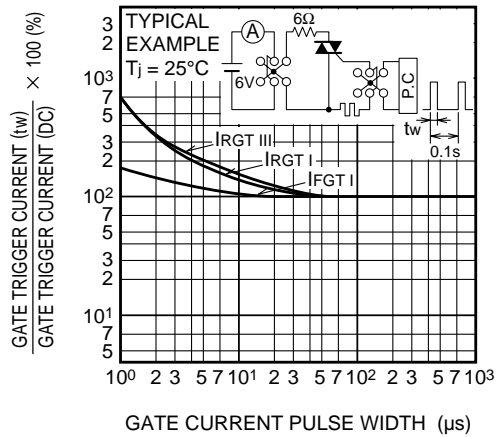

**GATE TRIGGER CHARACTERISTICS TEST CIRCUITS**

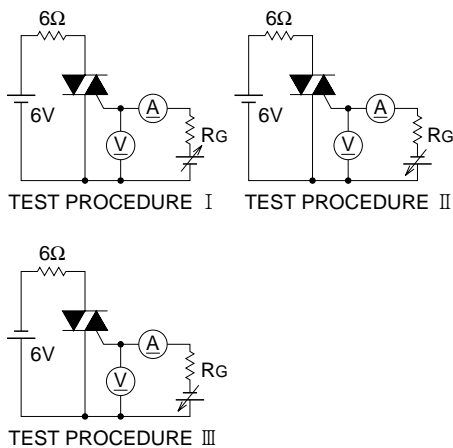



LittleDiode supplies new, hard to find or obsolete electronic components and semiconductors all over the world.

With over two million different components listed you are sure to find the part you need.

Feel free to visit us today at our online store:

[LittleDiode.com](http://LittleDiode.com)

Looking forward to providing you with the best possible service.