

BCR20A, BCR20B, BCR20C, BCR20E

MEDIUM POWER USE

A, B, C : NON-INSULATED TYPE, E : INSULATED TYPE, GLASS PASSIVATION TYPE

BCR20A, BCR20B, BCR20C, BCR20E



- I_T (RMS) 20A
- V_{DRM} 400V/500V
- $I_{FGT I}$, $I_{RGT I}$, $I_{RGT III}$ 30mA

OUTLINE DRAWING

Dimensions
in mm

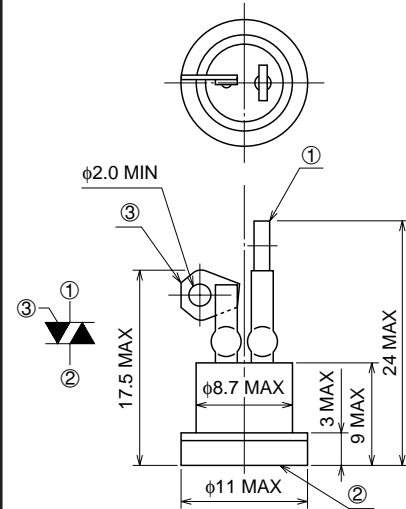

- ① T₁ TERMINAL
- ② T₂ TERMINAL
- ③ GATE TERMINAL

BCR20A

APPLICATION

Contactless AC switches, light dimmer,
on/off control of traffic signals, on/off control of copier lamps, microwave ovens,
solid state relay

MAXIMUM RATINGS

Symbol	Parameter	Voltage class		Unit
		8	12	
V_{DRM}	Repetitive peak off-state voltage*1	400	500	V
V_{DSM}	Non-repetitive peak off-state voltage*1	600	700	V

Symbol	Parameter	Conditions		Ratings	Unit
		BCR20A, B, C	BCR20E		
I_T (RMS)	RMS on-state current	Commercial frequency, sine full wave, 360° conduction	$T_c=98^\circ\text{C}$	20	A
I_{TSM}	Surge on-state current	60Hz sinewave 1 full cycle, peak value, non-repetitive		220	A
I^2_t	I^2_t for fusing	Value corresponding to 1 cycle of half wave 60Hz, surge on-state current		203	A ² s
PGM	Peak gate power dissipation			5.0	W
PG (AV)	Average gate power dissipation			0.5	W
VGM	Peak gate voltage			10	V
IGM	Peak gate current			2.0	A
T_j	Junction temperature			-20 ~ +125	°C
T_{stg}	Storage temperature			-20 ~ +125	°C

*1. Gate open.

BCR20A, BCR20B, BCR20C, BCR20E

MEDIUM POWER USE

A, B, C : NON-INSULATED TYPE, E : INSULATED TYPE, GLASS PASSIVATION TYPE

MAXIMUM RATINGS (continue)

Symbol	Parameter	Conditions	Ratings	Unit
—	Weight (Typical value)	BCR20A	3.5	g
		BCR20B	9.0	
		BCR20C	9.0	
		BCR20E	11	
—	Soldering temperature	BCR20A only, 10 sec.	230	°C
—	Mounting torque	BCR20C only	30	kg-cm
			2.94	N-m
Viso	Isolated voltage	BCR20E only, Ta=25°C, AC 1 minute, T2 terminal to base	1500	V

ELECTRICAL CHARACTERISTICS

Symbol	Parameter	Test conditions	Limits			Unit	
			Min.	Typ.	Max.		
IDRM	Repetitive peak off-state current	Tj=125°C, VDRM applied	—	—	3.0	mA	
V _{TM}	On-state voltage	Tc=25°C, Tb=25°C (BCR20E only), I _{TM} =30A, Instantaneous measurement	—	—	1.5	V	
V _{FGT I}	Gate trigger voltage *2	Tj=25°C, V _D =6V, R _L =6Ω, R _G =330Ω	I	—	—	1.5	V
V _{RGT I}			II	—	—	1.5	V
V _{RGT III}			III	—	—	1.5	V
I _{FGT I}	Gate trigger current *2	Tj=25°C, V _D =6V, R _L =6Ω, R _G =330Ω	I	—	—	30	mA
I _{RGT I}			II	—	—	30	mA
I _{RGT III}			III	—	—	30	mA
V _{GD}	Gate non-trigger voltage	Tj=125°C, V _D =1/2V _{DRM}	0.2	—	—	V	
R _{th (j-c)}	Thermal resistance	Junction to case (BCR20A, BCR20B, BCR20C)	—	—	1.1	°C/W	
R _{th (j-b)}		Junction to base (BCR20E)	—	—	2.4	°C/W	
(dv/dt) _c	Critical-rate of rise of off-state commutating voltage		*3	—	—	V/μs	

*2. Measurement using the gate trigger characteristics measurement circuit.

*3. The critical-rate of rise of the off-state commutating voltage is shown in the table below.

Voltage class	V _{DRM} (V)	(dv/dt) _c			Test conditions	Commutating voltage and current waveforms (inductive load)
		Symbol	Min.	Unit		
8	400	R	—	V/μs	1. Junction temperature Tj=125°C 2. Rate of decay of on-state commutating current (di/dt) _c =-10A/ms 3. Peak off-state voltage V _D =400V	
		L	10			
10	600	R	—			
		L	10			

BCR20A, BCR20B, BCR20C, BCR20E

MEDIUM POWER USE

A, B, C : NON-INSULATED TYPE, E : INSULATED TYPE, GLASS PASSIVATION TYPE

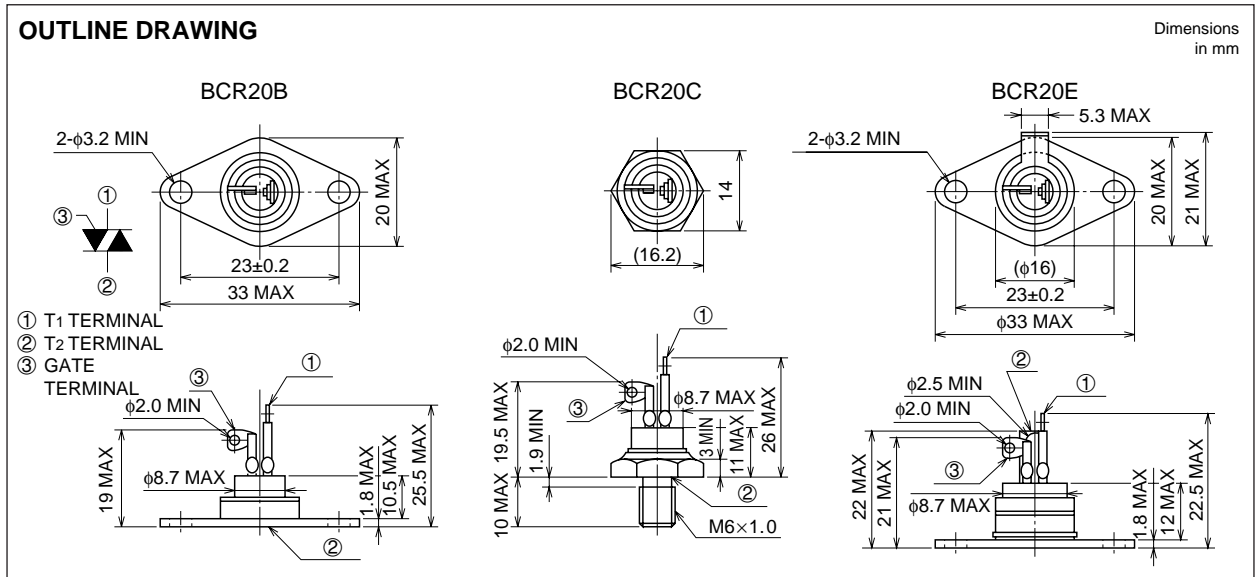

PERFORMANCE CURVES

MAXIMUM ON-STATE CHARACTERISTICS

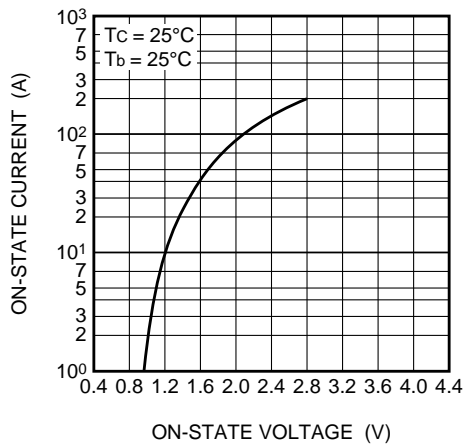

RATED SURGE ON-STATE CURRENT

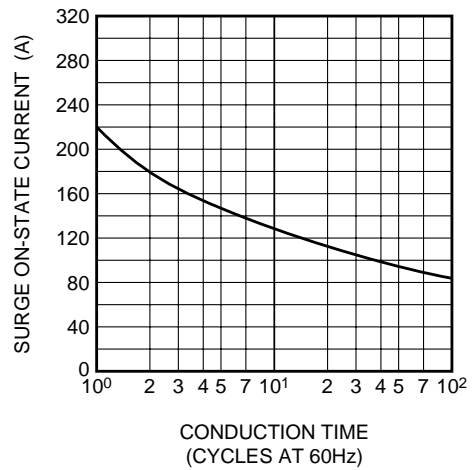

GATE CHARACTERISTICS

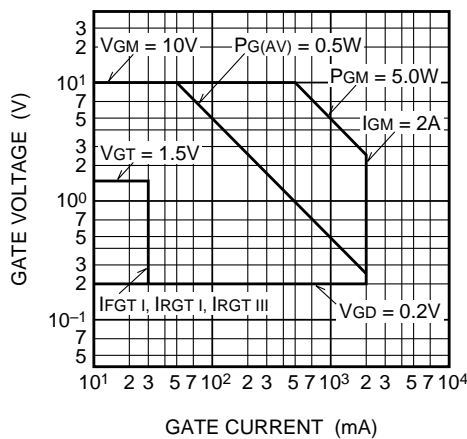

GATE TRIGGER CURRENT-VOLTAGE VS. JUNCTION TEMPERATURE

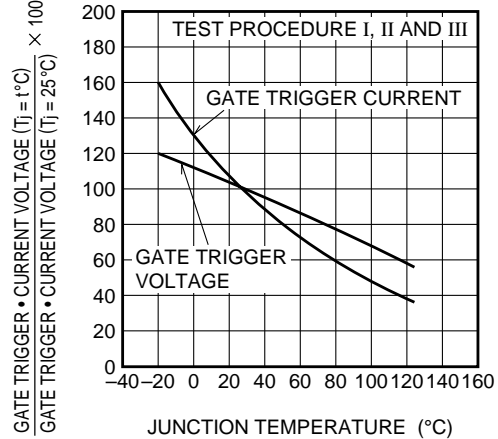

BCR20A, BCR20B, BCR20C, BCR20E

MEDIUM POWER USE

A, B, C : NON-INSULATED TYPE, E : INSULATED TYPE, GLASS PASSIVATION TYPE

MAXIMUM TRANSIENT THERMAL IMPEDANCE CHARACTERISTICS (JUNCTION TO CASE) (BCR20A, B, C)

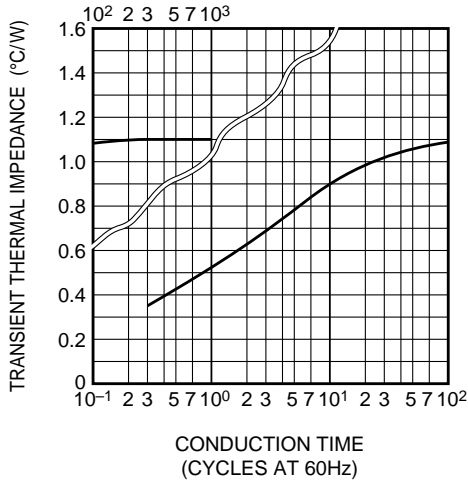

MAXIMUM TRANSIENT THERMAL IMPEDANCE CHARACTERISTICS (JUNCTION TO BASE) (BCR20E)

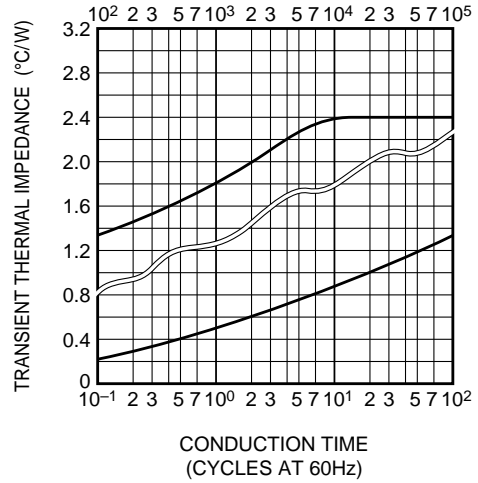

MAXIMUM ON-STATE POWER DISSIPATION

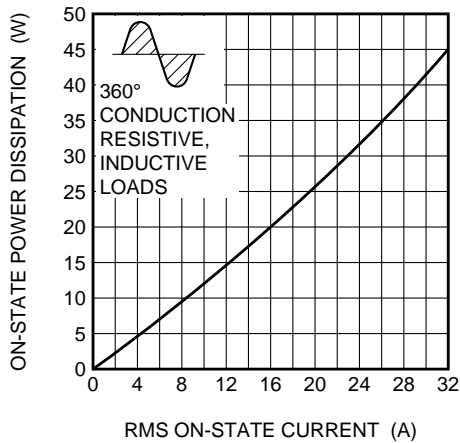

ALLOWABLE CASE TEMPERATURE VS. RMS ON-STATE CURRENT

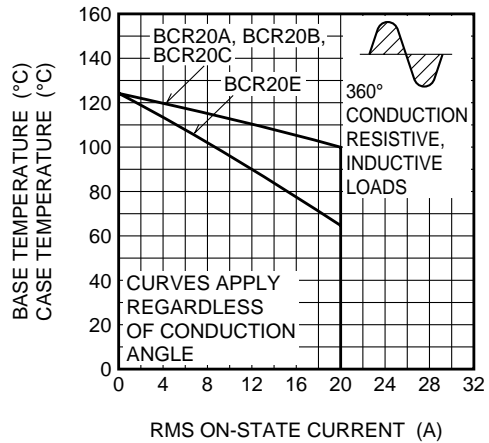

ALLOWABLE AMBIENT TEMPERATURE VS. RMS ON-STATE CURRENT (BCR20A)

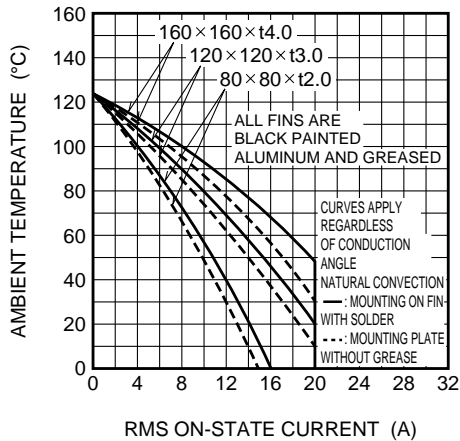

ALLOWABLE AMBIENT TEMPERATURE VS. RMS ON-STATE CURRENT (BCR20B)

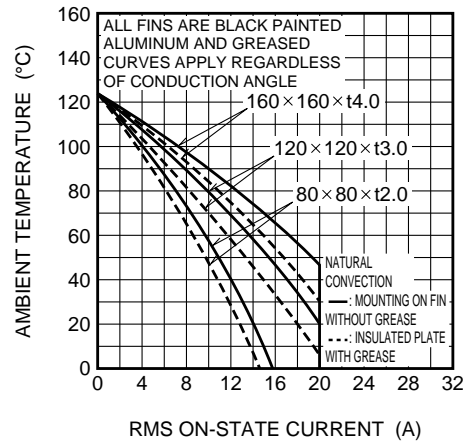

BCR20A, BCR20B, BCR20C, BCR20E

MEDIUM POWER USE

A, B, C : NON-INSULATED TYPE, E : INSULATED TYPE, GLASS PASSIVATION TYPE

ALLOWABLE AMBIENT TEMPERATURE VS. RMS ON-STATE CURRENT (BCR20C)

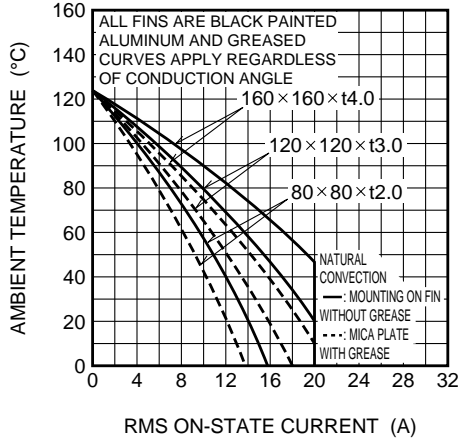

ALLOWABLE AMBIENT TEMPERATURE VS. RMS ON-STATE CURRENT (BCR20E)

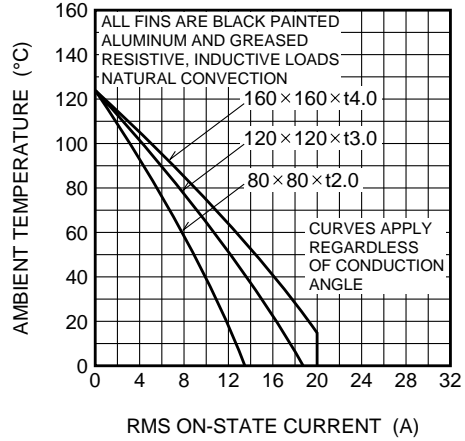

GATE TRIGGER CHARACTERISTICS TEST CIRCUITS

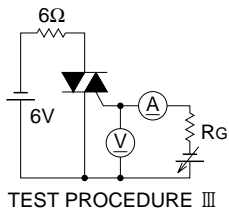
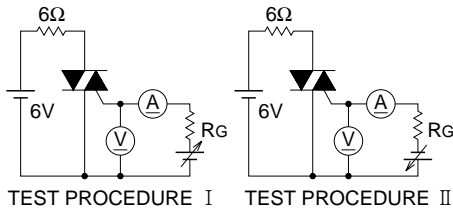



LittleDiode supplies new, hard to find or obsolete electronic components and semiconductors all over the world.

With over two million different components listed you are sure to find the part you need.

Feel free to visit us today at our online store:

LittleDiode.com

Looking forward to providing you with the best possible service.