

### Isolated Triac 12 Amperes/400-600 Volts

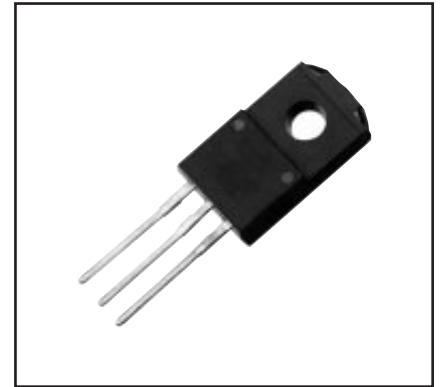
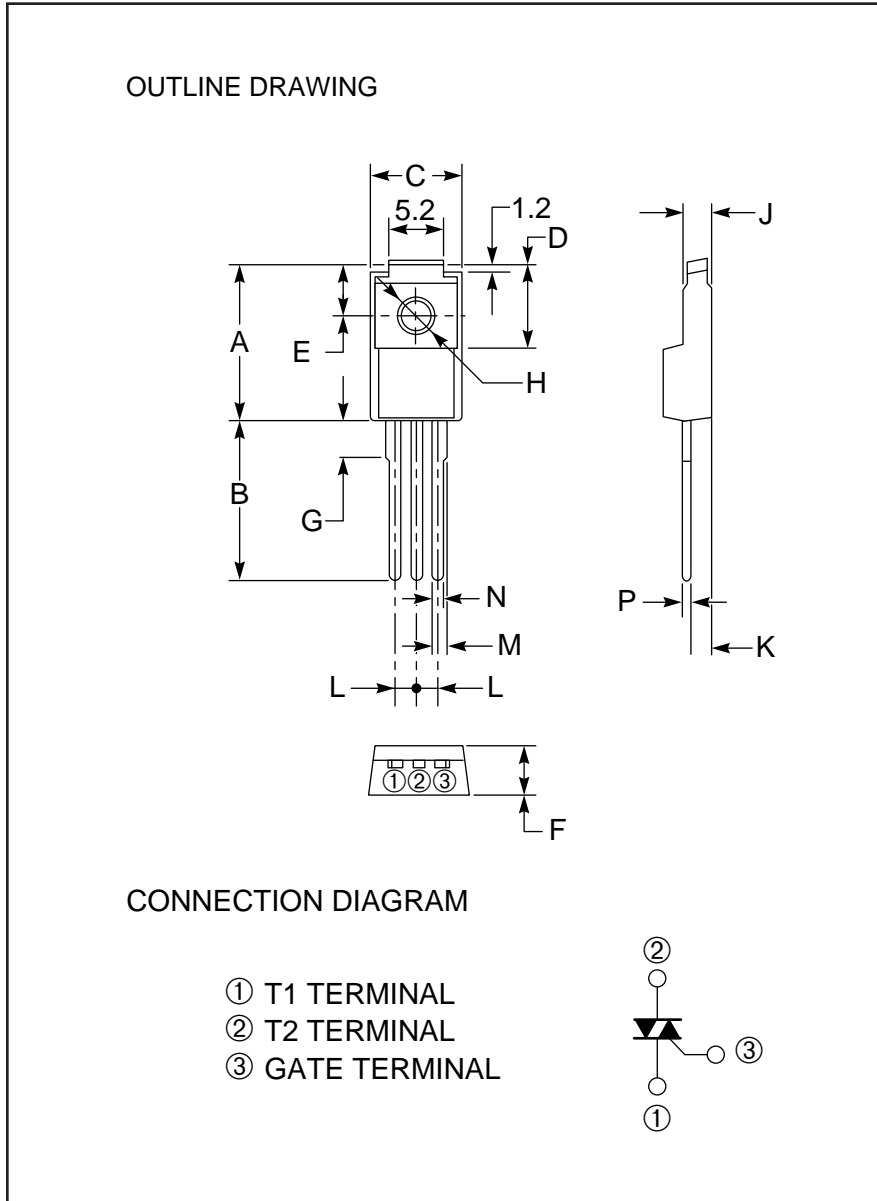

**Description:**

A triac is a solid state silicon AC switch which may be gate triggered from an off-state to an on-state for either polarity of applied voltage.

**Features:**

- Full Molded Isolation Package
- Glass Passivation
- 1500 V<sub>RMS</sub> Isolation Voltage
- Selected for Inductive Loads
- UL Approved

**Applications:**

- AC Switch
- Motor Controls
- Lighting

**Ordering Information:**

Example: Select the complete eight, nine or ten digit part number you desire from the table - i.e. BCR12PM-8 is a 400 Volt, 12 Ampere Triac.

Outline Drawing (Conforms to TO-220F)

Dimensions	Inches	Millimeters
A	0.67	17.0
B	0.49 Min.	12.5 Min.
C	0.39	10.0
D	0.33	8.5
E	0.20	5.0
F	0.18	4.5
G	0.14	3.6

Dimensions	Inches	Millimeters
H	0.126 ±0.008 Dia.	3.2 ±0.2 Dia.
J	0.11	2.8
K	0.102	2.6
L	0.10	2.5
M	0.039	1.0
N	0.031	0.8
P	0.020	0.5

Type	V <sub>DRM</sub> Volts	Code	Inductive Load*
BCR12PM	400	-8	L
	600	-12	

\*For inductive load, add L.



Powerex, Inc., 200 Hillis Street, Youngwood, Pennsylvania 15697-1800 (412) 925-7272

**BCR12PM**

**Isolated Triac**

12 Amperes/400-600 Volts

**Absolute Maximum Ratings,  $T_a = 25\text{ }^\circ\text{C}$  unless otherwise specified**

Ratings	Symbol	BCR12PM-8	BCR12PM-12	Units
Repetitive Peak Off-state Voltage	$V_{DRM}$	400	600	Volts
Non-repetitive Peak Off-state Voltage	$V_{DSM}$	500	720	Volts
On-state Current, $T_c = 74^\circ\text{C}$	$I_{T(RMS)}$	12	12	Amperes
Non-repetitive Peak Surge, One Cycle (60 Hz)	$I_{TSM}$	120	120	Amperes
$I^2t$ for Fusing, $t = 8.3\text{ msec}$	$I^2t$	60	60	$\text{A}^2\text{sec}$
Peak Gate Power Dissipation, 20 $\mu\text{sec}$	$P_{GM}$	5	5	Watts
Average Gate Power Dissipation	$P_{G(avg)}$	0.5	0.5	Watts
Peak Gate Current	$I_{GM}$	2	2	Amperes
Peak Gate Voltage	$V_{GM}$	10	10	Volts
Storage Temperature	$T_{stg}$	-40 to 125	-40 to 125	$^\circ\text{C}$
Operating Temperature	$T_j$	-40 to 125	-40 to 125	$^\circ\text{C}$
Isolation Voltage	$V_{iso}$	1500	1500	Volts
Weight	–	2	2	Grams



Powerex, Inc., 200 Hillis Street, Youngwood, Pennsylvania 15697-1800 (412) 925-7272

**BCR12PM**  
**Isolated Triac**  
 12 Amperes/400-600 Volts

**Electrical and Thermal Characteristics,  $T_j = 25\text{ }^\circ\text{C}$  unless otherwise specified**

Characteristics	Symbol	Test Conditions (Trigger Mode)			BCR12PM			Units
		$V_D$	$R_L$	$T_j$	Min.	Typ.	Max.	
Gate Parameters								
DC Gate Trigger Current								
MT2+ Gate+	$I_{GT}$	6V	6 $\Omega$	25 $^\circ\text{C}$	–	–	30	mA
MT2+ Gate–		6V	6 $\Omega$	25 $^\circ\text{C}$	–	–	30	mA
MT2– Gate–		6V	6 $\Omega$	25 $^\circ\text{C}$	–	–	30	mA
DC Gate Trigger Voltage								
MT2+ Gate+	$V_{GT}$	6V	6 $\Omega$	25 $^\circ\text{C}$	–	–	1.5	Volts
MT2+ Gate–		6V	6 $\Omega$	25 $^\circ\text{C}$	–	–	1.5	Volts
MT2– Gate–		6V	6 $\Omega$	25 $^\circ\text{C}$	–	–	1.5	Volts
DC Gate Non-trigger Voltage								
All	$V_{GD}$	1/2 $V_{DRM}$	–	125 $^\circ\text{C}$	0.2	–	–	Volts

**BCR12PM**

**Isolated Triac**

12 Amperes/400-600 Volts

**Electrical and Thermal Characteristics,  $T_j = 25\text{ }^\circ\text{C}$  unless otherwise specified**

Characteristics	Symbol	Test Conditions	Min.	Typ.	Max.	Units
Thermal Resistance, Junction-to-case	$R_{th(j-c)}$	–	–	–	3.5	$^\circ\text{C/W}$
Steady State Thermal Resistance, Junction-to-ambient	$R_{th(j-a)}$	–	–	–	60	$^\circ\text{C/W}$
Voltage – Blocking State Repetitive Off-state Current	$I_{DRM}$	Gate Open Circuited, $V_D = V_{DRM}, T_j = 125^\circ\text{C}$	–	–	2	mA
Current – Conducting State Peak On-state voltage	$V_{TM}$	$T_c = 25^\circ\text{C},$ $I_{TM} = 20\text{A}$	–	–	1.6	Volts
Critical Rate-of-rise of Commutating Off-state Voltage (Commutating $dv/dt$ ) ▲ for inductive load (L) (Switching)	$(dv/dt)_c$	–	–	–	–	$\text{V}/\mu\text{s}$

$\Delta$ Part Number	$V_{DRM}$ (Volts)	Commutating $dv/dt, (dv/dt)_c$ ( $\text{V}/\mu\text{sec}$ )		Test Condition	Commutating Voltage & Current Waveform (Inductive Load)
		Load Type	Minimum		
BCR12PM-8L	400	L	10	$T_j = 125^\circ\text{C},$	
BCR12PM-12L	600	L	10	Rate of Decay On-state Commutating Current $(di/dt)_c = -6\text{A/msec};$ Peak Off-state Voltage $V_D = 400\text{V}$	

**BCR12PM**  
**Isolated Triac**  
 12 Amperes/400-600 Volts

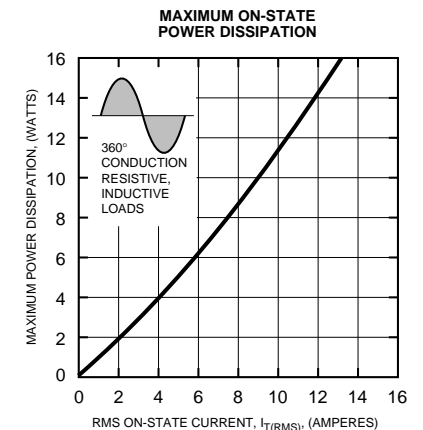
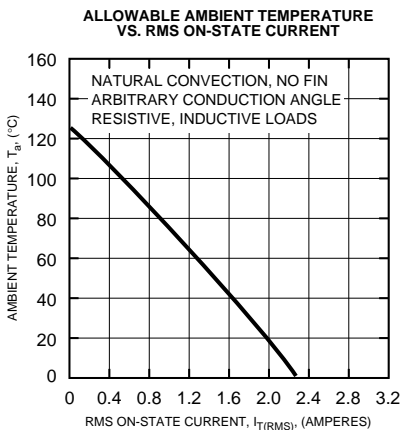
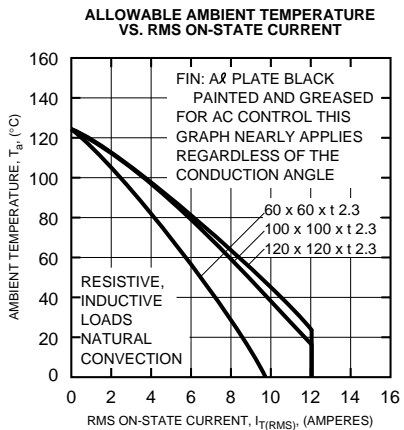
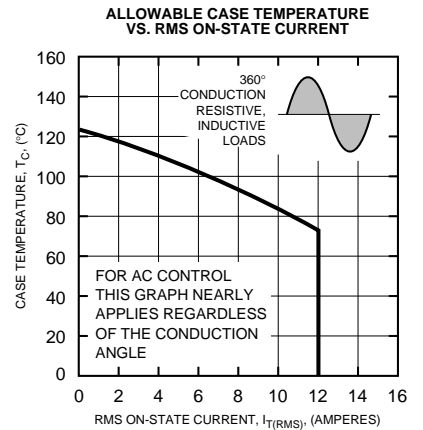
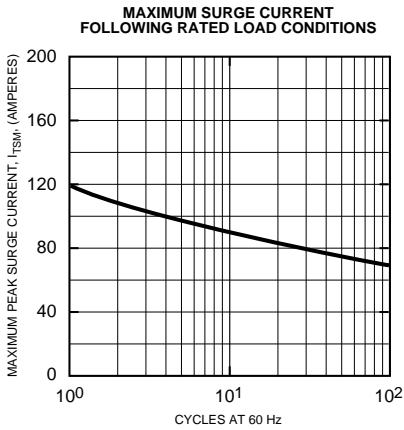
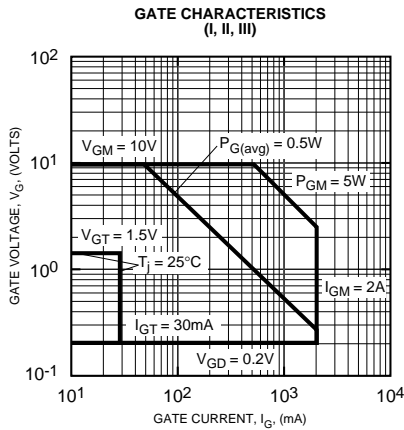
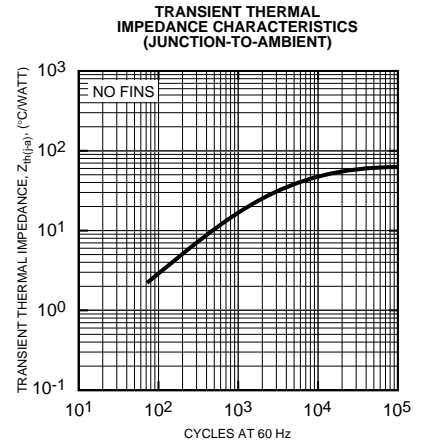
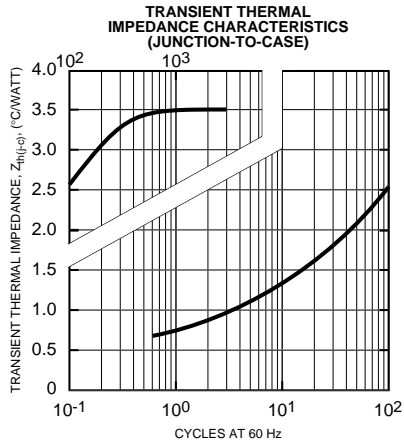
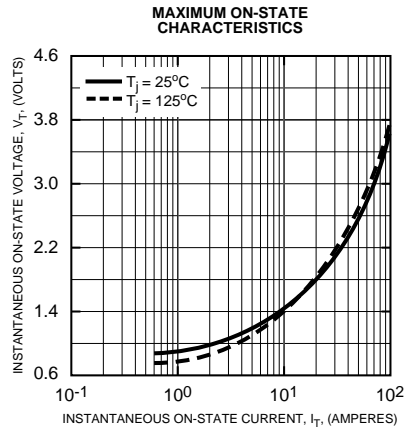

**BCR12PM**  
**Isolated Triac**  
 12 Amperes/400-600 Volts

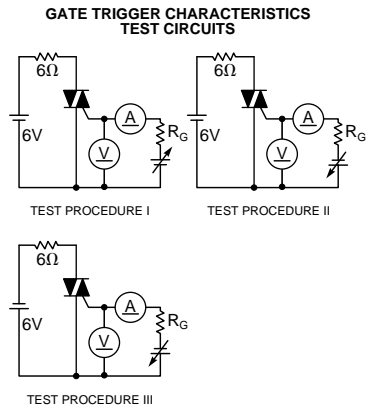
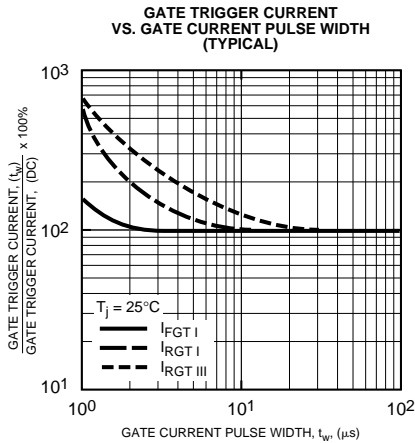
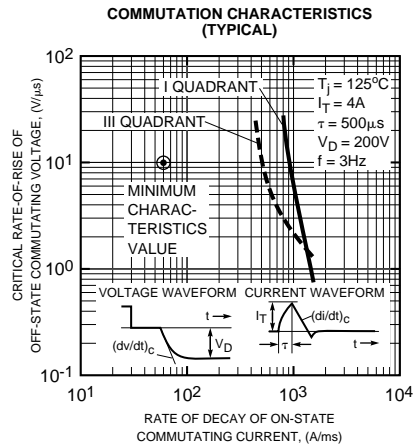
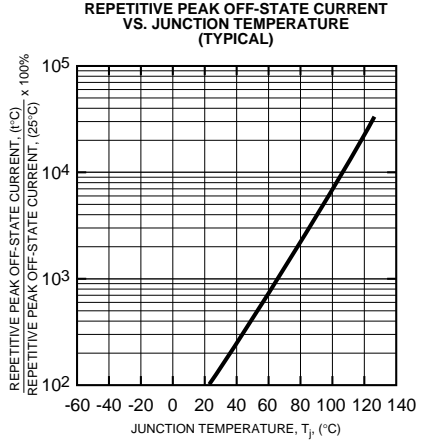
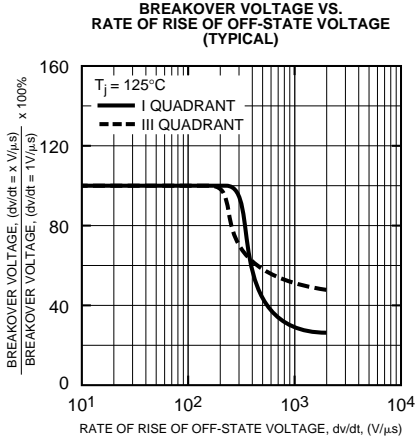
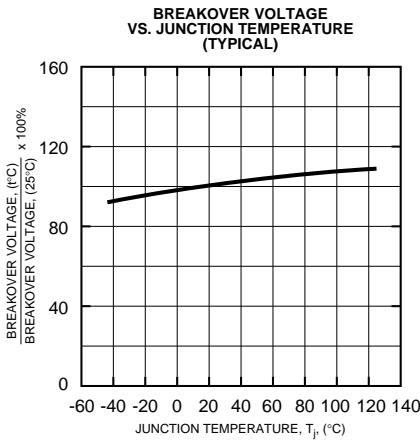
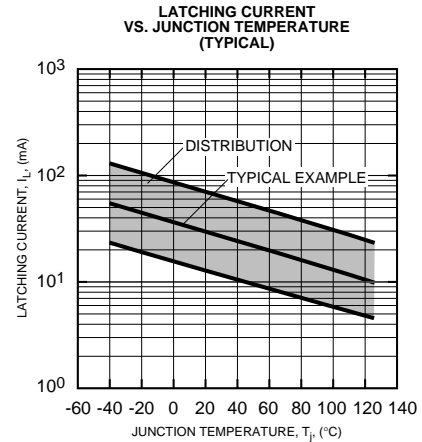
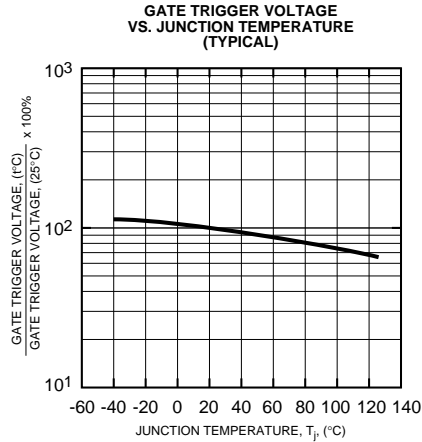
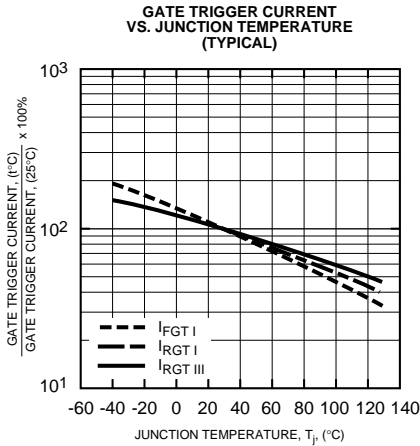



LittleDiode supplies new, hard to find or obsolete electronic components and semiconductors all over the world.

With over two million different components listed you are sure to find the part you need.

Feel free to visit us today at our online store:

[LittleDiode.com](http://LittleDiode.com)

Looking forward to providing you with the best possible service.