

Outline Drawing (Conforms to TO-220)

| Dimensions | Inches             | Millimeters    |
|------------|--------------------|----------------|
| A          | 0.63 Max.          | 16.0 Max.      |
| B          | 0.49 Max.          | 12.5 Max.      |
| C          | 0.41 Max.          | 10.5 Max.      |
| D          | 0.28               | 7.0            |
| E          | 0.18               | 4.5            |
| F          | 0.15 Max.          | 3.8 Max.       |
| G          | 0.142 ± 0.008 Dia. | 3.6 ± 0.2 Dia. |
| H          | 0.125 ± 0.008      | 3.2 ± 0.2      |

| Dimensions | Inches | Millimeters |
|------------|--------|-------------|
| J          | 0.99   | 2.54        |
| K          | 0.10   | 2.6         |
| L          | 0.051  | 1.3         |
| M          | 0.051  | 1.3         |
| N          | 0.039  | 1.0         |
| P          | 0.031  | 0.8         |
| Q          | 0.020  | 0.5         |

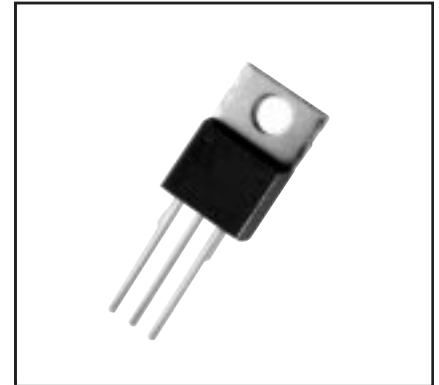

#### Description:

A triac is a solid state silicon AC switch which may be gate triggered from an off-state to an on-state for either polarity of applied voltage.

#### Features:

- Glass Passivation
- Excellent Surge Capability
- Selected for Inductive Loads

#### Applications:

- AC Switch
- Heating
- Motor Controls
- Lighting
- Solid State Relay

#### Ordering Information:

Example: Select the complete eight, nine or ten digit part number you desire from the table - i.e. BCR10CM-8 is a 400 Volt, 10 Ampere Triac

| Type    | V <sub>DRM</sub><br>Volts | Code | Inductive<br>Load* |
|---------|---------------------------|------|--------------------|
| BCR10CM | 400                       | -8   | L                  |
|         | 600                       | -12  |                    |

\*For inductive load, add L.



Powerex, Inc., 200 Hillis Street, Youngwood, Pennsylvania 15697-1800 (412) 925-7272

**BCR10CM**

Triac

10 Amperes/400-600 Volts

**Absolute Maximum Ratings,  $T_a = 25\text{ }^\circ\text{C}$  unless otherwise specified**

| Ratings  | Symbol       | BCR10CM-8  | BCR10CM-12 | Units                  |
|--|--------------|------------|------------|------------------------|
| Repetitive Peak Off-state Voltage                                      | $V_{DRM}$    | 400        | 600        | Volts                  |
| Non-repetitive Peak Off-state Voltage                                  | $V_{DSM}$    | 500        | 720        | Volts                  |
| On-state Current, $T_c = 103^\circ\text{C}$ , $T_c = 93^\circ\text{C}$ | $I_{T(RMS)}$ | 10         | 10         | Amperes                |
| Non-repetitive Peak Surge, One Cycle (60 Hz)                           | $I_{TSM}$    | 100        | 100        | Amperes                |
| $I^2t$ for Fusing, $t = 8.3\text{ msec}$                               | $I^2t$       | 41.6       | 41.6       | $\text{A}^2\text{sec}$ |
| Peak Gate Power Dissipation, 20 $\mu\text{sec}$                        | $P_{GM}$     | 5          | 5          | Watts                  |
| Average Gate Power Dissipation   | $P_{G(avg)}$ | 0.5        | 0.5        | Watts                  |
| Peak Gate Current  | $I_{GM}$     | 2          | 2          | Amperes                |
| Peak Gate Voltage  | $V_{GM}$     | 10         | 10         | Volts                  |
| Storage Temperature  | $T_{stg}$    | -40 to 125 | -40 to 125 | $^\circ\text{C}$       |
| Operating Temperature  | $T_j$        | -40 to 125 | -40 to 125 | $^\circ\text{C}$       |
| Weight   | –            | 2.3        | 2.3        | Grams                  |



Powerex, Inc., 200 Hillis Street, Youngwood, Pennsylvania 15697-1800 (412) 925-7272

**BCR10CM**

Triac

10 Amperes/400-600 Volts

**Electrical and Thermal Characteristics,  $T_j = 25\text{ }^\circ\text{C}$  unless otherwise specified**

| Characteristics             | Symbol   | Test Conditions (Trigger Mode) |            |              |                      | BCR10CM |      |      | Units |
|-----------------------------|----------|--------------------------------|------------|--------------|----------------------|---------|------|------|-------|
|                             |          | $V_D$                          | $R_L$      | $R_G$        | $T_j$                | Min.    | Typ. | Max. |       |
| Gate Parameters             |          |                                |            |              |                      |         |      |      |       |
| DC Gate Trigger Current     |          |                                |            |              |                      |         |      |      |       |
| MT2+ Gate+                  | $I_{GT}$ | 6V                             | 6 $\Omega$ | 330 $\Omega$ | 25 $^\circ\text{C}$  | –       | –    | 30   | mA    |
| MT2+ Gate–                  |          | 6V                             | 6 $\Omega$ | 330 $\Omega$ | 25 $^\circ\text{C}$  | –       | –    | 30   | mA    |
| MT2– Gate–                  |          | 6V                             | 6 $\Omega$ | 330 $\Omega$ | 25 $^\circ\text{C}$  | –       | –    | 30   | mA    |
| DC Gate Trigger Voltage     |          |                                |            |              |                      |         |      |      |       |
| MT2+ Gate+                  | $V_{GT}$ | 6V                             | 6 $\Omega$ | 330 $\Omega$ | 25 $^\circ\text{C}$  | –       | –    | 1.5  | Volts |
| MT2+ Gate–                  |          | 6V                             | 6 $\Omega$ | 330 $\Omega$ | 25 $^\circ\text{C}$  | –       | –    | 1.5  | Volts |
| MT2– Gate–                  |          | 6V                             | 6 $\Omega$ | 330 $\Omega$ | 25 $^\circ\text{C}$  | –       | –    | 1.5  | Volts |
| DC Gate Non-trigger Voltage |          |                                |            |              |                      |         |      |      |       |
| All                         | $V_{GD}$ | $1/2 V_{DRM}$                  | –          | –            | 125 $^\circ\text{C}$ | 0.2     | –    | –    | Volts |

**BCR10CM**

Triac

10 Amperes/400-600 Volts

**Electrical and Thermal Characteristics,  $T_j = 25\text{ }^\circ\text{C}$  unless otherwise specified**

| Characteristics  | Symbol        | Test Conditions  | Min. | Typ. | Max. | Units                  |
|--|---------------|--|------|------|------|------------------------|
| Thermal Resistance, Junction-to-case   | $R_{th(j-c)}$ | –  | –    | –    | 1.8  | $^\circ\text{C/W}$     |
| Voltage – Blocking State Maximums<br>Repetitive Off-state Current  | $I_{DRM}$     | $V_{DRM}$ = Maximum Allowable<br>Repetitive Off-state Voltage Rating,<br>Gate Open Circuited,<br>$T_j = 125^\circ\text{C}$ | –    | –    | 2    | mA                     |
| Current – Conducting State Maximums<br>Peak On-state Voltage   | $V_{TM}$      | $T_C = 25^\circ\text{C}$ ,<br>$I_{TM} = 15\text{A}$  | –    | –    | 1.5  | Volts                  |
| Critical Rate-of-rise of Commutating<br>Off-state Voltage (Commutating $dv/dt$ )<br>▲ for inductive load (L) | $(dv/dt)_C$   | –  | –    | –    | –    | $\text{V}/\mu\text{s}$ |

| $\Delta$ Part<br>Number | $V_{DRM}$<br>(Volts) | Commutating<br>$dv/dt, (dv/dt)_C$<br>( $\text{V}/\mu\text{sec}$ ) |  | Test Condition  | Commutating Voltage &<br>Current Waveform<br>(Inductive Load) |
|-------------------------|----------------------|---|--|---|---|
|                         |                      | Minimum   |  |   |   |
| BCR10CM-8L              | 400                  | 10  |  | $T_j = 125^\circ\text{C}$ ,   |   |
| BCR10CM-12L             | 600                  | 10  |  | Rate of Decay<br>On-state<br>Commutating Current<br>$(di/dt)_C = -5\text{A/msec}$ :<br>Peak Off-state<br>Voltage<br>$V_D = 400\text{V}$ |   |

## BCR10CM

### Triac

10 Amperes/400-600 Volts

**MAXIMUM ON-STATE CHARACTERISTICS**

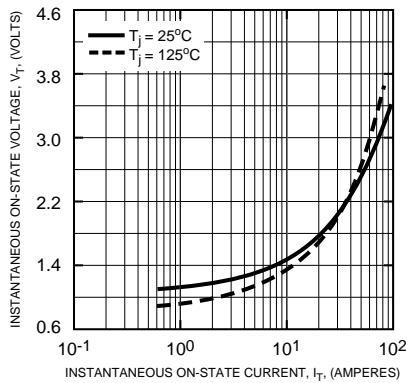

**TRANSIENT THERMAL IMPEDANCE CHARACTERISTICS (JUNCTION-TO-CASE)**

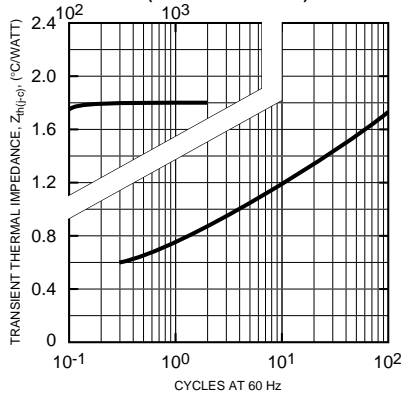

**GATE CHARACTERISTICS (I, II, III)**

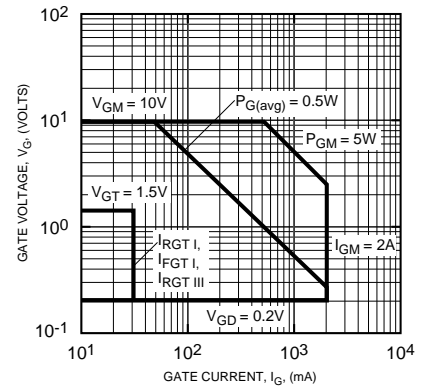

**MAXIMUM SURGE CURRENT FOLLOWING RATED LOAD CONDITIONS**

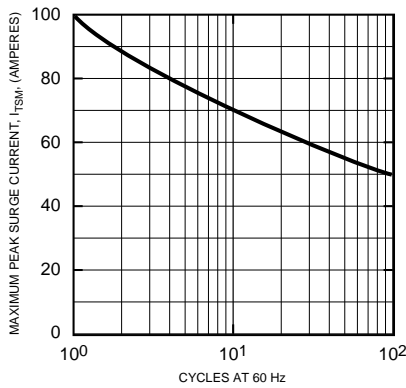

**ALLOWABLE CASE TEMPERATURE VS. RMS ON-STATE CURRENT**

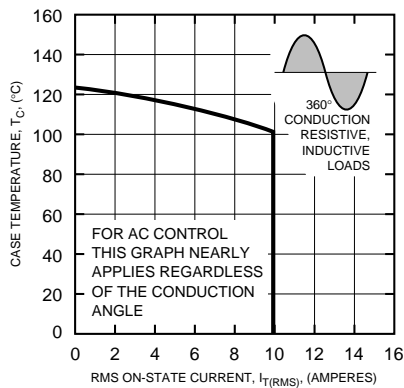

**ALLOWABLE AMBIENT TEMPERATURE VS. RMS ON-STATE CURRENT**

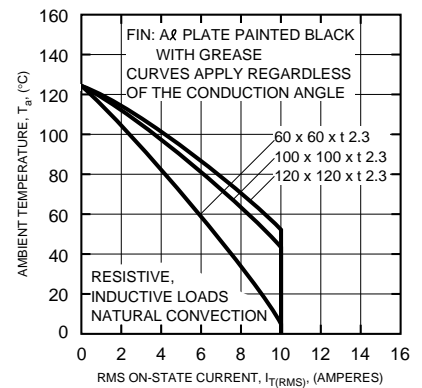

**ALLOWABLE AMBIENT TEMPERATURE VS. RMS ON-STATE CURRENT**

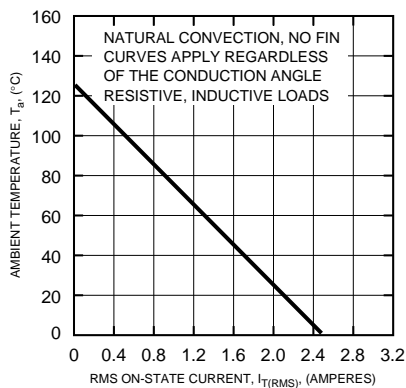

**MAXIMUM ON-STATE POWER DISSIPATION**

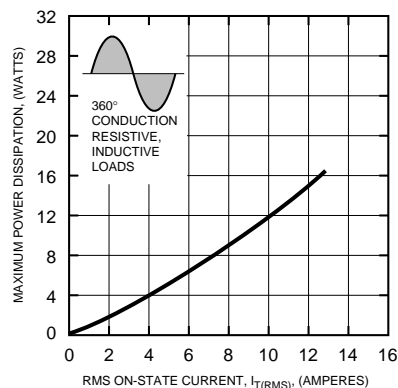

**GATE TRIGGER CURRENT VS. JUNCTION TEMPERATURE (TYPICAL)**

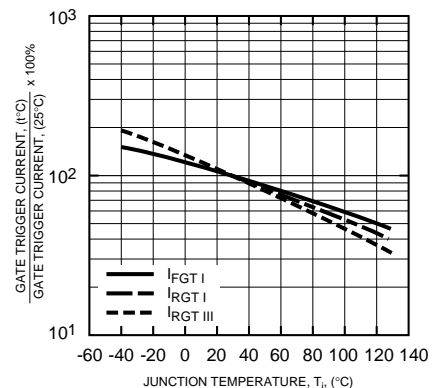

## BCR10CM

### Triac

10 Amperes/400-600 Volts

**GATE TRIGGER VOLTAGE VS. JUNCTION TEMPERATURE (TYPICAL)**

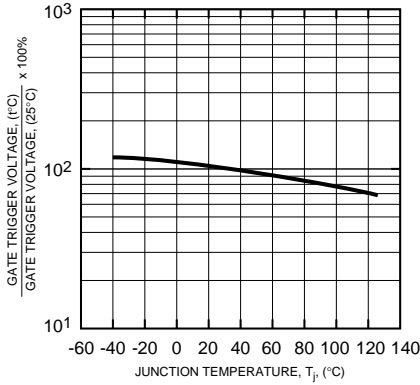

**HOLDING CURRENT VS. JUNCTION TEMPERATURE (TYPICAL)**

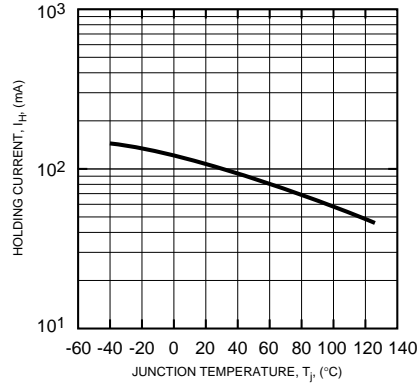

**BREAKOVER VOLTAGE VS. JUNCTION TEMPERATURE (TYPICAL)**

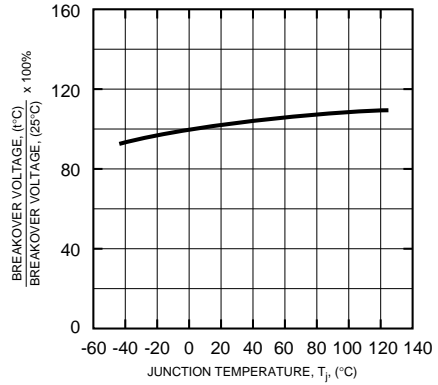

**BREAKOVER VOLTAGE VS. RATE OF RISE OF OFF-STATE VOLTAGE (TYPICAL)**

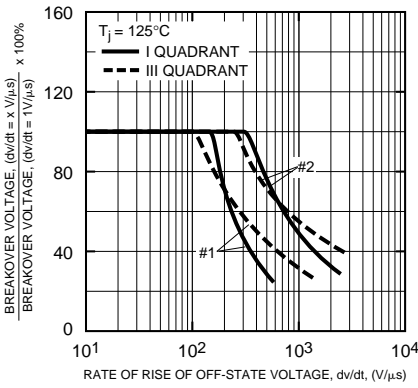

**REPETITIVE PEAK OFF-STATE CURRENT VS. JUNCTION TEMPERATURE (TYPICAL)**

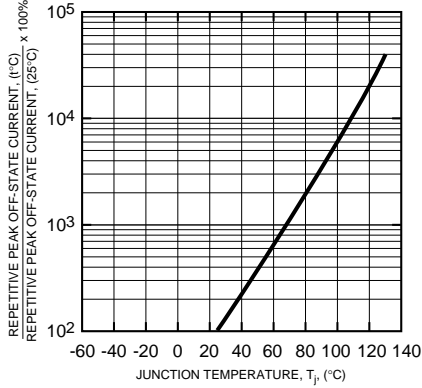

**COMMUTATION CHARACTERISTICS (TYPICAL)**

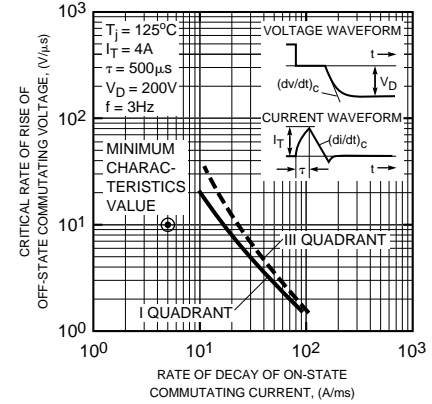

**GATE TRIGGER CURRENT VS. GATE CURRENT PULSE WIDTH (TYPICAL)**

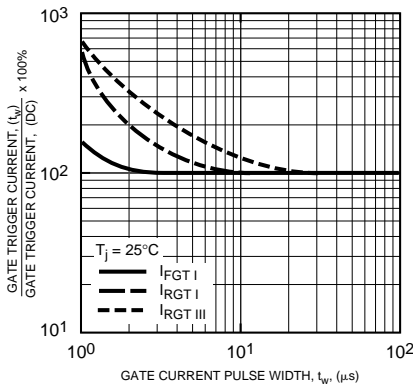

**GATE TRIGGER CHARACTERISTICS TEST CIRCUITS**

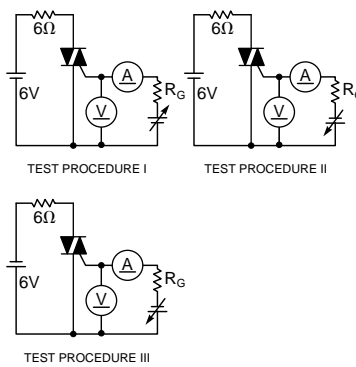



LittleDiode supplies new, hard to find or obsolete electronic components and semiconductors all over the world.

With over two million different components listed you are sure to find the part you need.

Feel free to visit us today at our online store:

**[LittleDiode.com](http://LittleDiode.com)**

Looking forward to providing you with the best possible service.