

# BCR08AM-14

LOW POWER USE  
PLANAR PASSIVATION TYPE

**BCR08AM-14**



- $I_T$  (RMS) ..... 0.8A
- $V_{DRM}$  ..... 700V
- IFGT I , IRGT I , IRGT III ..... 5mA

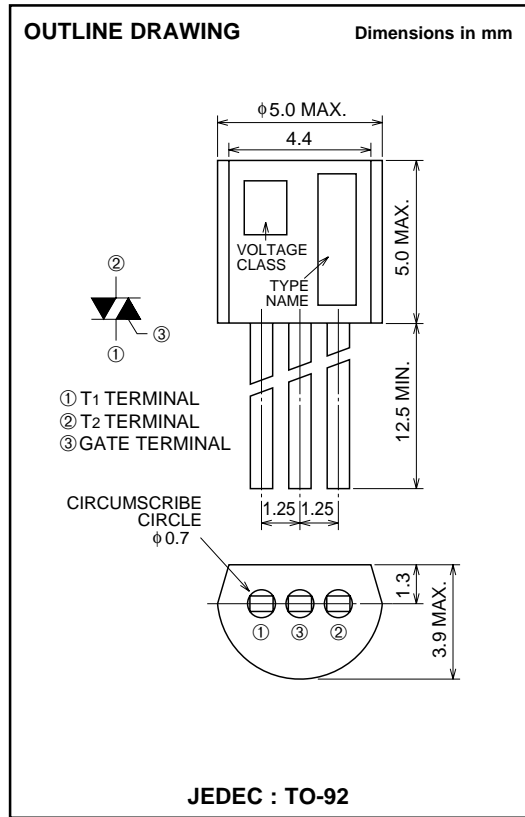

## APPLICATION

Washing machine, electric fan, air cleaner, other general purpose control applications

## MAXIMUM RATINGS

Symbol	Parameter	Voltage class		Unit
		14	700	
$V_{DRM}$	Repetitive peak off-state voltage*1	700		V
$V_{DSM}$	Non-repetitive peak off-state voltage*1	840		V

Symbol	Parameter	Conditions	Ratings	Unit
$I_T$ (RMS)	RMS on-state current	Commercial frequency, sine full wave 360° conduction, $T_c=67^\circ\text{C}$	0.8	A
$I_{TSM}$	Surge on-state current	60Hz sinewave 1 full cycle, peak value, non-repetitive	8	A
$I^2t$	$I^2t$ for fusing	Value corresponding to 1 cycle of half wave 60Hz, surge on-state current	0.26	A <sup>2</sup> s
$P_{GM}$	Peak gate power dissipation		1	W
$P_{G(AV)}$	Average gate power dissipation		0.1	W
$V_{GM}$	Peak gate voltage		6	V
$I_{GM}$	Peak gate current		0.5	A
$T_j$	Junction temperature		-40 ~ +125	°C
$T_{stg}$	Storage temperature		-40 ~ +125	°C
—	Weight	Typical value	0.23	g

\*1. Gate open.

# BCR08AM-14

LOW POWER USE  
PLANAR PASSIVATION TYPE

## ELECTRICAL CHARACTERISTICS

Symbol	Parameter	Test conditions	Limits			Unit	
			Min.	Typ.	Max.		
I <sub>DRM</sub>	Repetitive peak off-state current	T <sub>j</sub> =125°C, V <sub>DRM</sub> applied	—	—	1.0	mA	
V <sub>TM</sub>	On-state voltage	T <sub>c</sub> =25°C, I <sub>TM</sub> =1.2A, Instantaneous measurement	—	—	2.0	V	
V <sub>FGT I</sub>	Gate trigger voltage *2	T <sub>j</sub> =25°C, V <sub>D</sub> =6V, R <sub>L</sub> =6Ω, R <sub>G</sub> =330Ω	I	—	—	2.0	V
V <sub>RGT I</sub>			II	—	—	2.0	V
V <sub>RGT III</sub>			III	—	—	2.0	V
I <sub>FGT I</sub>	Gate trigger current *2	T <sub>j</sub> =25°C, V <sub>D</sub> =6V, R <sub>L</sub> =6Ω, R <sub>G</sub> =330Ω	I	—	—	5	mA
I <sub>RGT I</sub>			II	—	—	5	mA
I <sub>RGT III</sub>			III	—	—	5	mA
V <sub>GD</sub>	Gate non-trigger voltage	T <sub>j</sub> =125°C, V <sub>D</sub> =1/2V <sub>DRM</sub>	0.1	—	—	V	
R <sub>th(j-c)</sub>	Thermal resistance	Junction to case *3	—	—	50	°C/W	
(dv/dt) <sub>c</sub>	Critical-rate of rise of off-state commutating voltage *4	T <sub>j</sub> =125°C	0.5	—	—	V/μs	

\*2. Measurement using the gate trigger characteristics measurement circuit.

\*3. Case temperature is measured at the T<sub>2</sub> terminal 1.5mm away from the molded case.

\*4. Test conditions of the critical-rate of rise of off-state commutating voltage is shown in the table below.

Test conditions	Commutating voltage and current waveforms (inductive load)
1. Junction temperature T <sub>j</sub> =125°C  2. Rate of decay of on-state commutating current (di/dt) <sub>c</sub> =-0.4A/ms  3. Peak off-state voltage V <sub>D</sub> =400V	

## PERFORMANCE CURVES

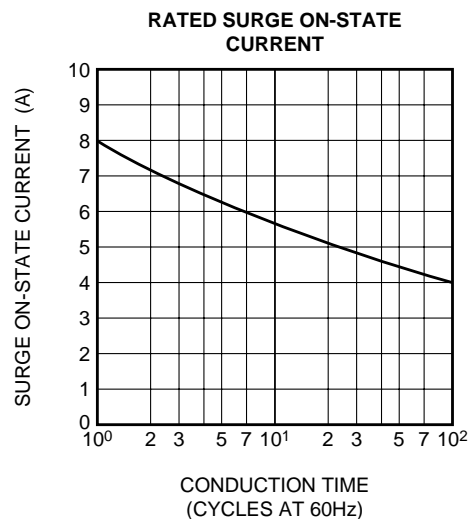
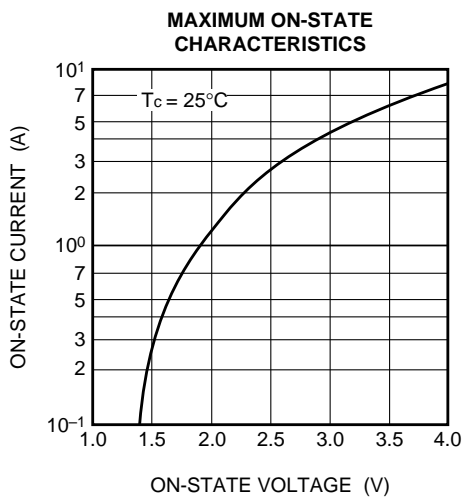

# BCR08AM-14

LOW POWER USE  
PLANAR PASSIVATION TYPE

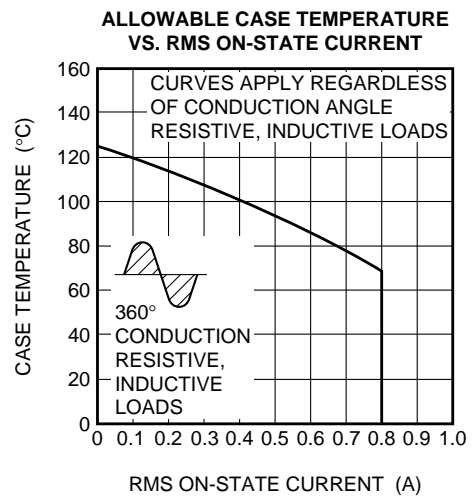
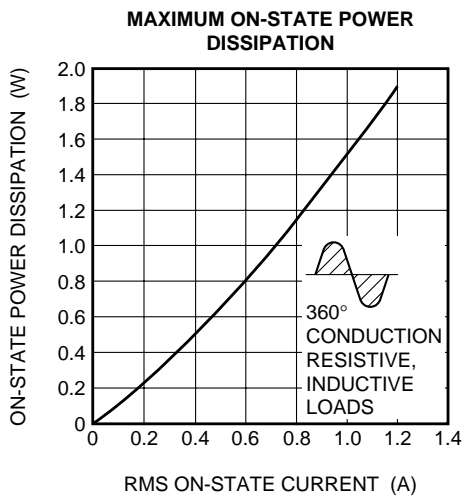
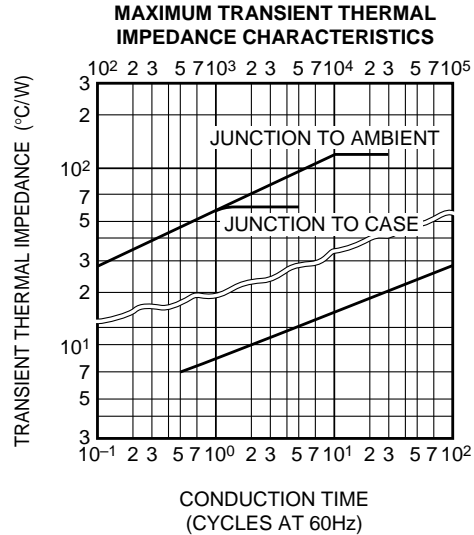
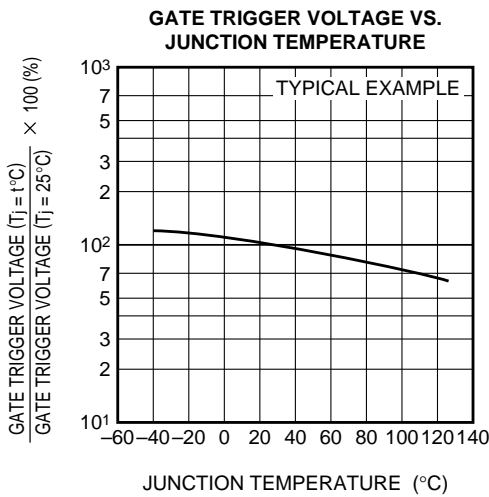
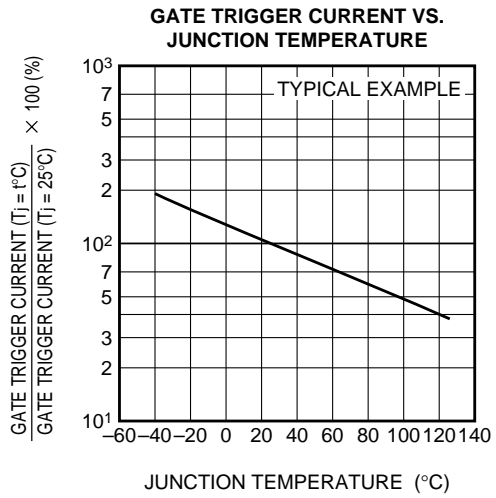
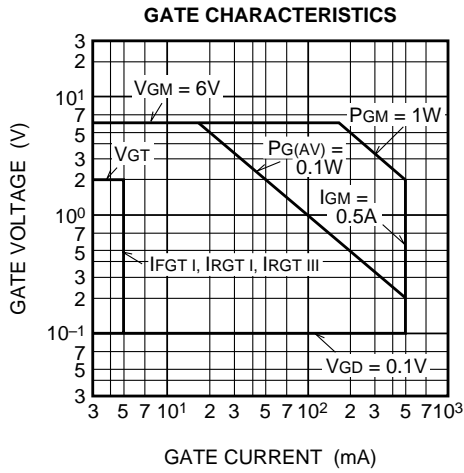

# BCR08AM-14

LOW POWER USE  
PLANAR PASSIVATION TYPE

**ALLOWABLE AMBIENT TEMPERATURE VS. RMS ON-STATE CURRENT**

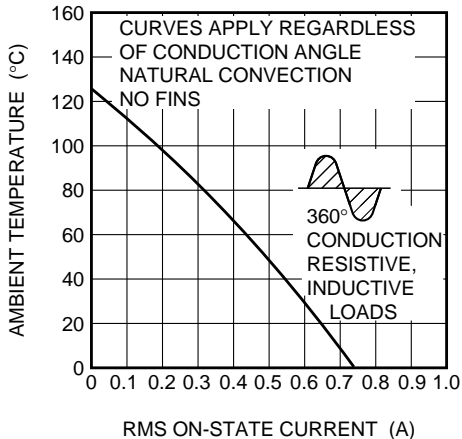

**REPETITIVE PEAK OFF-STATE CURRENT VS. JUNCTION TEMPERATURE**

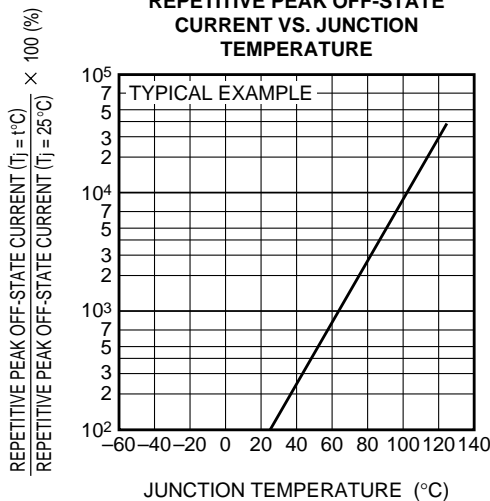

**HOLDING CURRENT VS. JUNCTION TEMPERATURE**

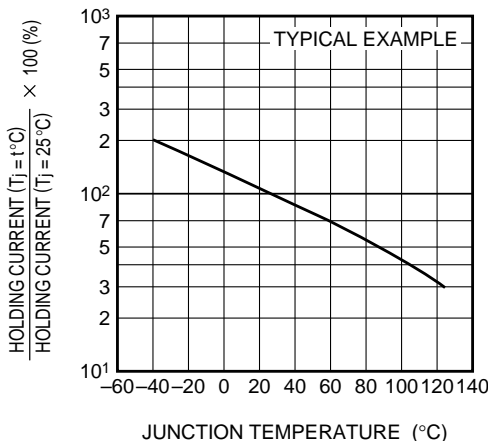

**LATCHING CURRENT VS. JUNCTION TEMPERATURE**

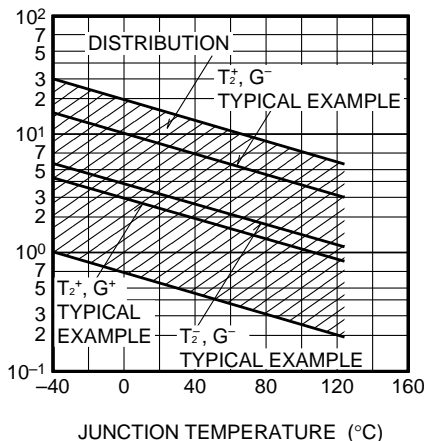

**BREAKOVER VOLTAGE VS. JUNCTION TEMPERATURE**

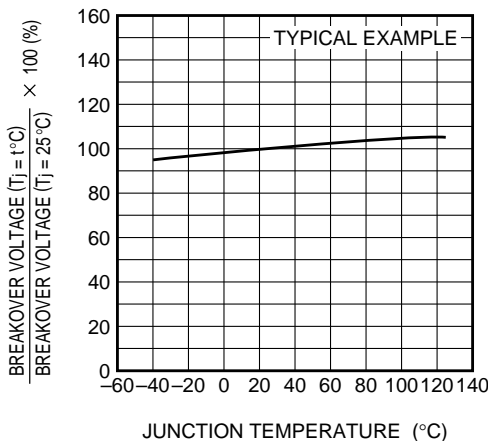

**BREAKOVER VOLTAGE VS. RATE OF RISE OF OFF-STATE VOLTAGE**

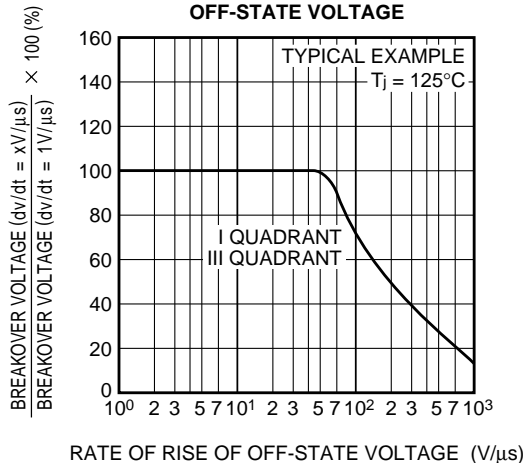

# BCR08AM-14

LOW POWER USE  
PLANAR PASSIVATION TYPE

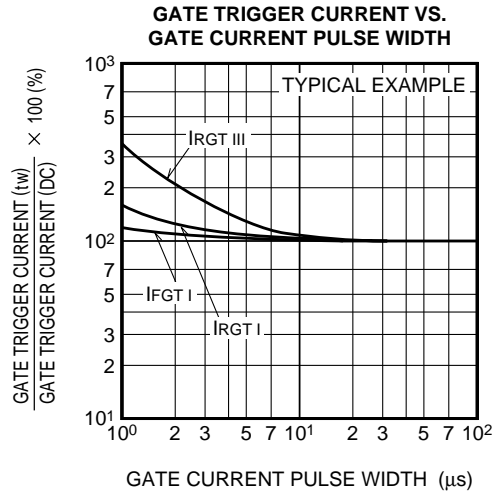
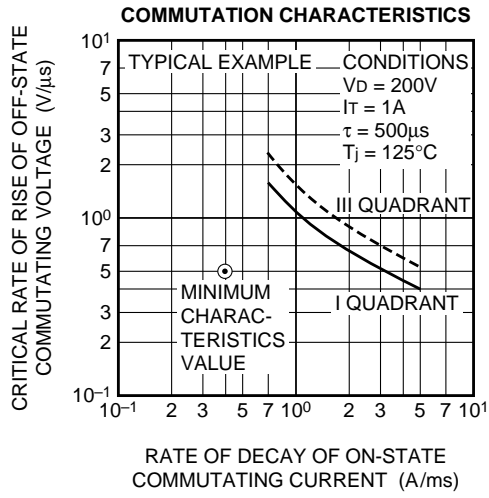

**GATE TRIGGER CHARACTERISTICS TEST CIRCUITS**

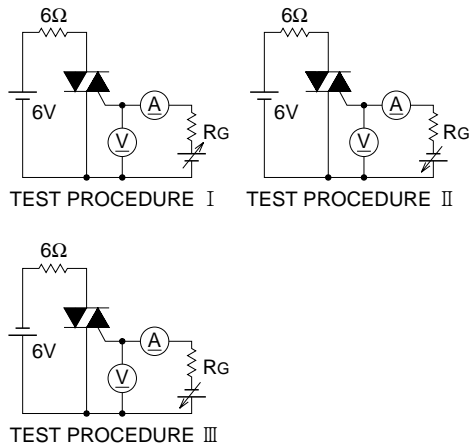



LittleDiode supplies new, hard to find or obsolete electronic components and semiconductors all over the world.

With over two million different components listed you are sure to find the part you need.

Feel free to visit us today at our online store:

[LittleDiode.com](http://LittleDiode.com)

Looking forward to providing you with the best possible service.