

### PNP Silicon AF Power Transistor

#### Preliminary data

- For AF driver and output stages
- High collector current
- High current gain
- Low collector-emitter saturation voltage

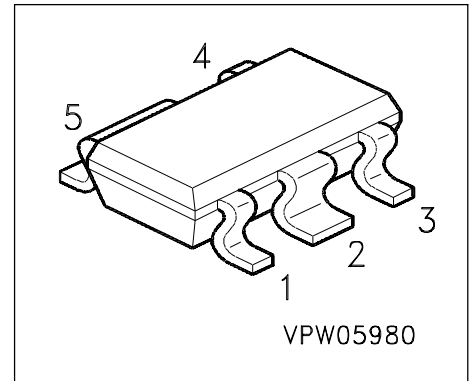

Type	Marking	Ordering Code	Pin Configuration					Package
BCP 72	PAs	Q62702-	1 = E	2 = C	3 = E	4 = B	5 = C	SOT-23-5

#### Maximum Ratings

Parameter	Symbol	Values	Unit
Collector-emitter voltage	$V_{CEO}$	15	V
Collector-base voltage	$V_{CBO}$	15	
Emitter-base voltage	$V_{EBO}$	5	
DC collector current	$I_C$	3	A
Peak collector current	$I_{CM}$	6	
Base current	$I_B$	200	mA
Peak base current	$I_{BM}$	500	
Total power dissipation, $T_S = 99^\circ\text{C}$	$P_{tot}$	1.7	W
Junction temperature	$T_j$	150	$^\circ\text{C}$
Storage temperature	$T_{stg}$	- 65 ... + 150	

#### Thermal Resistance

Junction ambient <sup>1)</sup>	$R_{thJA}$	$\leq 55$	K/W
Junction - soldering point	$R_{thJS}$	$\leq 30$	

1) Package mounted on pcb 40mm x 40mm x 1.5mm / 6cm<sup>2</sup> Cu

## Electrical Characteristics at $T_A=25^\circ\text{C}$ , unless otherwise specified

Parameter	Symbol	Values			Unit
		min.	typ.	max.	
<b>DC Characteristics</b>					
Collector-emitter breakdown voltage $I_C = 100 \mu\text{A}, I_B = 0$	$V_{(BR)CEO}$	15	-	-	V
Collector-base breakdown voltage $I_C = 100 \mu\text{A}, I_B = 0$	$V_{(BR)CBO}$	15	-	-	
Base-emitter breakdown voltage $I_E = 10 \mu\text{A}, I_C = 0$	$V_{(BR)EBO}$	5	-	-	
Collector cutoff current $V_{CB} = 15 \text{ V}, I_E = 0, T_A = 25^\circ\text{C}$ $V_{CB} = 15 \text{ V}, I_E = 0, T_A = 150^\circ\text{C}$	$I_{CBO}$	-	-	100 20	nA $\mu\text{A}$
Emitter cutoff current $V_{EB} = 4 \text{ V}, I_C = 0$	$I_{EBO}$	-	-	100	nA
DC current gain $I_C = 10 \text{ mA}, V_{CE} = 5 \text{ V}$ $I_C = 500 \text{ mA}, V_{CE} = 1 \text{ V}$ $I_C = 1 \text{ A}, V_{CE} = 2 \text{ V}$	$h_{FE}$	25 85 50	- - -	- 475 -	-
Collector-emitter saturation voltage 1) $I_C = 2 \text{ A}, I_B = 0.2 \text{ A}$	$V_{CEsat}$	-	0.15	-	V
Base-emitter saturation voltage 1) $I_C = 2 \text{ A}, I_B = 0.2 \text{ A}$	$V_{BEsat}$	-	-	1.2	mV
<b>AC Characteristics</b>					
Transition frequency $I_C = 50 \text{ mA}, V_{CE} = 10 \text{ V}, f = 100 \text{ MHz}$	$f_T$	-	100	-	MHz
Collector-base capacitance $V_{CB} = 10 \text{ V}, f = 1 \text{ MHz}$	$C_{cb}$	-	50	-	pF

1) Pulse test:  $t < 300\mu\text{s}; D < 2\%$

**DC current gain  $h_{FE} = f(I_C)$**

$V_{CE} = 2V$

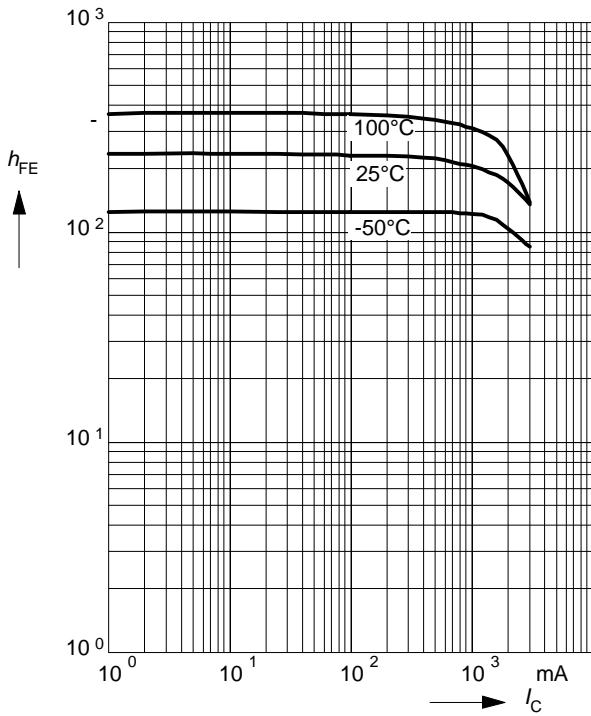

**Collector-emitter saturation voltage  $I_C = f(V_{CEsat}), h_{FE} = 10$**

$I_C = f(V_{CEsat}), h_{FE} = 10$

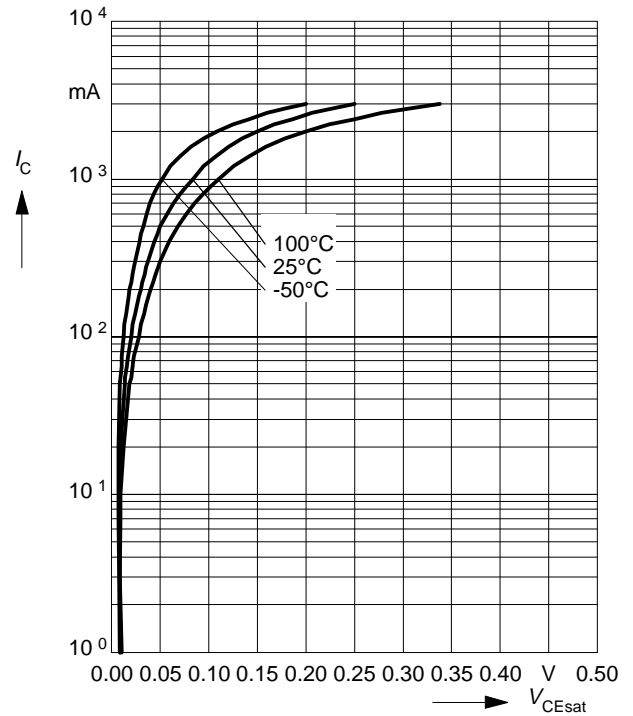

**Base-emitter saturation voltage  $I_C = f(V_{BEsat}), h_{FE} = 10$**

$I_C = f(V_{BEsat}), h_{FE} = 10$

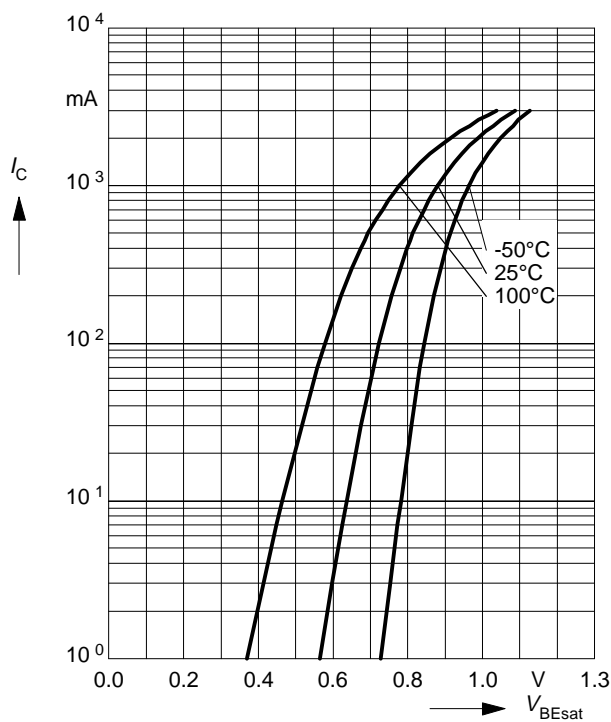

**Collector current  $I_C = f(V_{BE})$**

$V_{CE} = 2V$

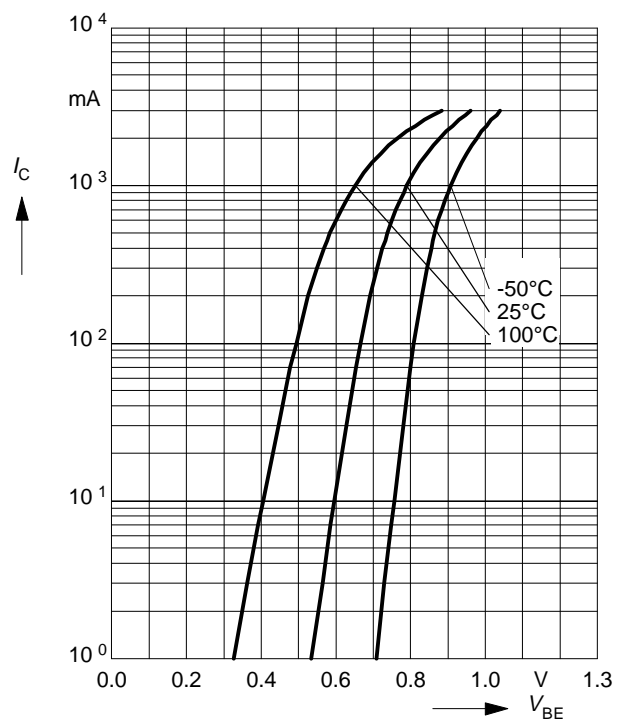



LittleDiode supplies new, hard to find or obsolete electronic components and semiconductors all over the world.

With over two million different components listed you are sure to find the part you need.

Feel free to visit us today at our online store:

[LittleDiode.com](http://LittleDiode.com)

Looking forward to providing you with the best possible service.