

# AN1607

## ITC122 Low Voltage Micro to Motor Interface

By Bill Lucas and Warren Schultz

A MOSFET power stage that is designed to run Brush or Brushless DC motors with input signals from an ASB124 Motion Control Development Board is presented here. It will

supply up to 4 amps continuous current from DC bus voltages up to 48 volts.

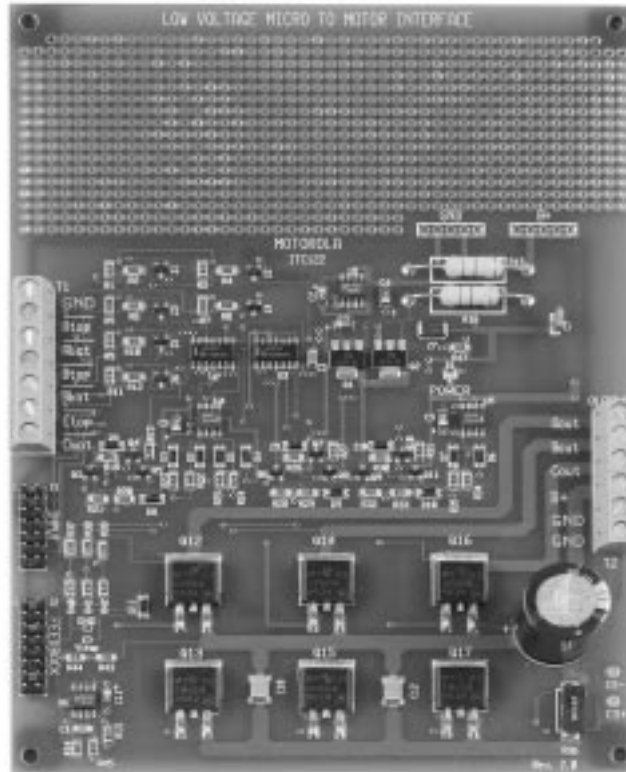

Figure 1. ITC122 — Low Voltage Micro to Motor Interface

### EVALUATION BOARD DESCRIPTION

A summary of the information required to use ITC122 Low Voltage Micro to Motor Interface boards is presented as follows. A discussion of the design appears under the heading Design Considerations.

#### Function

The evaluation board shown in Figure 1 is designed to provide a direct interface between microcomputers and fractional horsepower motors. It accepts 6 logic inputs which

control 3 complementary Half-Bridge outputs, and is arranged such that a logic ZERO at the input turns on the corresponding power transistor. This type of configuration is applicable to pulse width modulated (PWM) systems where the PWM signal is generated in a microcomputer, digital signal processor, or other digital system. It is suitable for driving fractional horsepower Brush and Brushless DC motors. In addition to controlling the motor, current sense, temperature sense, and bus voltage feedback are provided. This board is designed to interface directly with Motorola ASB124 motor control development boards.

## AN1607

Coupled with an ASB124 control board, it completes the link between software development tools and a motor. Its use allows code to be written before hardware design is completed in an environment where mechanical outputs can be seen. The design can also be used as a reference for speeding hardware development.

## Electrical Characteristics

The following electrical characteristics apply to operation at 25 degrees Celsius, and unless otherwise specified, B+ = 24 volts.

**Table 1. Electrical Characteristics**

Characteristic	Symbol	Min	Typ	Max	Units
Power Supply Voltage	B+	12		48	Volts
RMS Motor Current — Two Phases Active — Three Phases Active	I <sub>M</sub>			4 5	Amps Amps
Input Current @ V <sub>IN</sub> = 5 V	I <sub>in</sub>		500		μA
Min Logic 1 Input Voltage	V <sub>IH</sub>		2.7		Volts
Max Logic 0 Input Voltage	V <sub>IL</sub>		2.0		Volts
Quiescent Current	I <sub>CC</sub>		25		mA
Bus Current Sense Voltage	I <sub>sense</sub>		250		mV/A
Temperature Sense Voltage	V <sub>temp</sub>		.65		Volts
Bus Voltage Sense Voltage	V <sub>bus</sub>		50		mV/V
Power Dissipation — Two Phases Active — Three Phases Active	P <sub>DISS</sub>		5.5 6.75		Watts Watts

The above numbers for power dissipation assume still air and no additional heat sinking. Maximum current ratings are based upon applying pulse width modulation signals only to the top inputs, a maximum PWM frequency of 23 KHz, and a

maximum supply voltage of 40 volts. Bonding heat sinks to the back of the board and/or providing air flow will significantly increase both power dissipation and output current ratings.

## Content

Board contents are described by the following schematic and parts list. A pin by pin circuit description follows in the next section.

**Table 2. Parts List**

Designators	Qty.	Description	Rating	Manufacturer	Part Number
C11, C2–C4, C8, C9	6	1 $\mu$ F Capacitor	25 V	Digi–Key	PCS5105CT–ND
C5	1	.1 $\mu$ F Capacitor	50 V	Digi–Key	PCC104BCT–ND
C6	1	220 $\mu$ F	63 V	Digi–Key	P6736–ND
C7, C10	2	.1 $\mu$ F Capacitor	100 V	Sprague	1C105Z5U104M100B
C1	1	.001 $\mu$ F Capacitor	50 V	Sprague	PCC102CCT–ND
D1	1	LED SOT–23		Digi–Key	LT–1076–ND
D2–D10	9	Schottky Diode SOD–123	40 V	Motorola	MBR0540T1
D11	1	SOD–123 Diode	30 V	Motorola	MMSD1000T1
J1	1	2x7 .1o.c. Jumper Block	Note: 2	Digi–Key	S2011–36–ND
J2	1	2x8 .1o.c. Jumper Block	Note: 2	Digi–Key	S2011–36–ND
Q13, Q15, Q17	3	N–Channel Power TMOS FET		Motorola	MTB36N06V
Q12, Q14, Q16	3	P–Channel Power TMOS FET		Motorola	MTB30P06V
Q3, Q4, Q6, Q7, Q9, Q10	6	Small Signal NPN Transistor		Motorola	MMBTA06LT1
Q5, Q8, Q11	3	Small Signal PNP Transistor		Motorola	MMBTA56LT1
Q1, Q2	2	Small Signal NPN Transistor		Motorola	BCP56T1
R36	1	.01 Ohm Resistor 1%	1.5 Watt	OHMITE	RW1S5CAR010F
R13, R45	2	1.02K Ohm Resistor 1%		Yageo	
R15, R16	2	4.7K Resistor	1 Watt	Yageo	
R17	1	1.8K Resistor		Yageo	
R37–R39, R43	4	37.4K Ohm Resistor 1%		Yageo	
R40–R42, R44	4	1.96K Ohm Resistor 1%		Yageo	
R14	1	24.3K Ohm Resistor 1%		Yageo	
R2, R4, R6, R8, R10, R12	6	1K Resistor		Yageo	
R1, R3, R5, R7, R9, R11	6	10K Resistor		Yageo	
R19, R27, R31	3	820 Ohm Resistor		Yageo	
R18, R26, R30	3	4.3K Resistor		Yageo	
R20, R29, R33	3	56 Ohm Resistor		Yageo	
R21, R28, R32	3	91 Ohm Resistor		Yageo	
R22, R24, R34	3	270 Ohm Resistor		Yageo	
R23, R25, R35	3	150 Ohm Resistor		Yageo	
T1	1	7 Screw Terminal Connector		Phoenix Contact	MKDSN 1,5/7–5,08
T2	1	6 Screw Terminal Connector		Phoenix Contact	MKDSN 1,5/6–5,08
U1	1	5 Volt Regulator		Motorola	MC78L05ACD
U2, U3	2	Quad NAND Gate		Motorola	MC74HC02D
U4, U5	2	MOSFET Driver		Motorola	MC34152D
U6	1	Dual Rail to Rail Op–Amp		Motorola	MC33202D
Z1–Z6	6	Zener Diode SOT–23	4.7 V	Motorola	BZX84C4Z7LT1
Z7	1	Zener Diode SMB	15 V	Motorola	P6SMB15AT3
Z8–Z10	3	Zener Diode SOD–123	12 V	Motorola	MMSZ5242BT1
No Designator	4	Self Stick Rubber Feet			
ITC122	1	Printed Circuit Board			



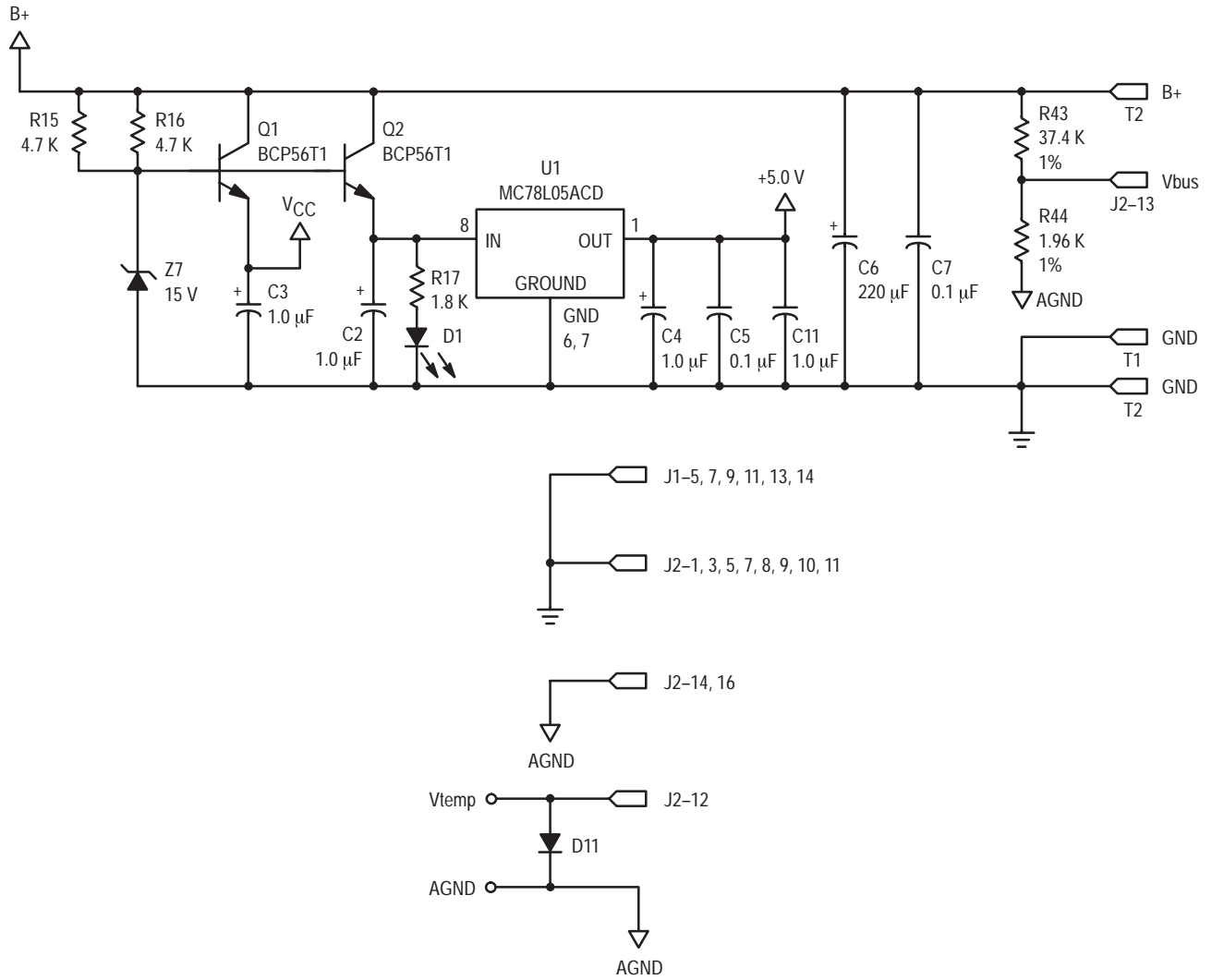

Figure 3. Schematic

## AN1607

### Pin By Pin Description

Inputs and outputs are grouped into four connectors. Two connectors are provided for inputs, one with screw terminals and the other for ribbon cable. Either can be used, they are wired in parallel. Outputs to the motor, B+, and ground are also supplied on a screw connector. Feedback signals are grouped

together on a separate ribbon cable connector. In addition, through-hole pads have been placed immediately adjacent to R36 and D11 for easy access to the current feedback resistor and temperature sensing diode. Ribbon connector PINOUTS are shown in Figure 4.

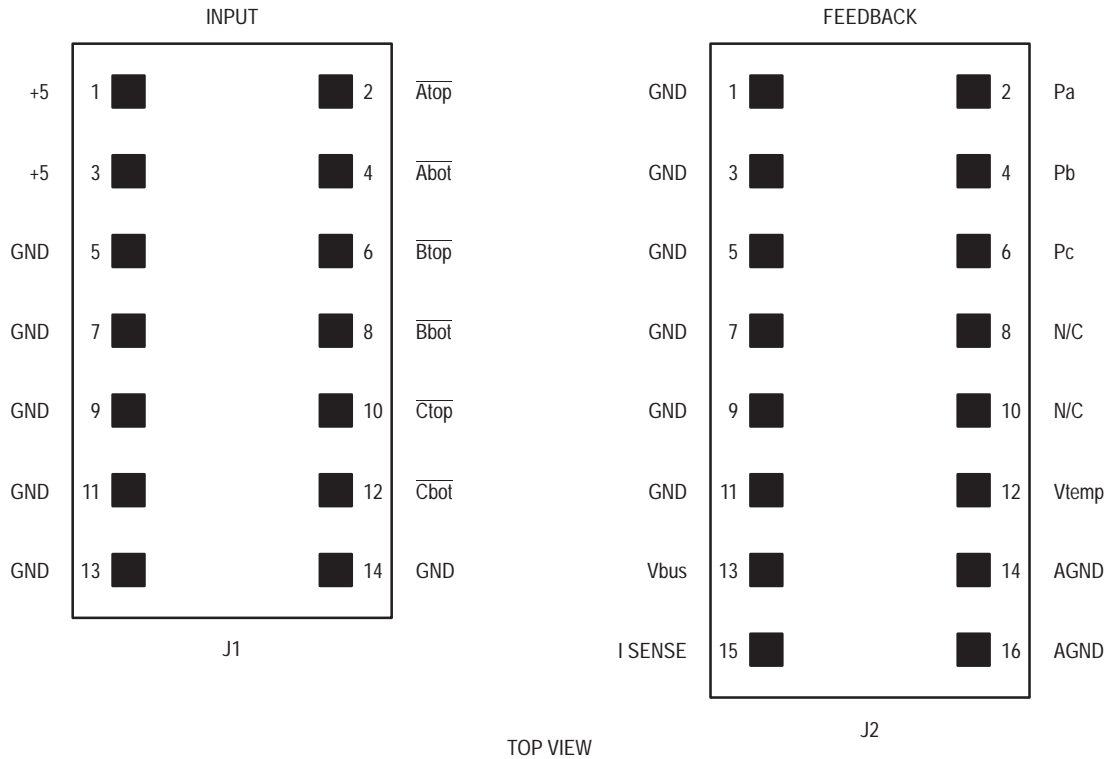

Figure 4. Connector Pinouts

#### Inputs:

Inputs  $\overline{A_{top}}$ ,  $\overline{A_{bot}}$ ,  $\overline{B_{top}}$ ,  $\overline{B_{bot}}$ ,  $\overline{C_{top}}$ , and  $\overline{C_{bot}}$  are logic inputs. A logic 0 turns on the input's corresponding output transistor, i.e., a logic 0 on  $\overline{A_{top}}$  turns on output transistor  $A_{top}$ , etc. Logic levels are standard 5 volt CMOS. Input current is higher, typically 500  $\mu$ A, since each of these inputs is pulled up with a 10K resistor. In the absence of any inputs all output transistors are turned off.

If a logic 0 is inadvertently applied to both top and bottom inputs for one phase, i.e.,  $\overline{A_{top}}$  &  $\overline{A_{bot}}$ , the bottom input is locked out and only the top output transistor is turned on. This feature helps protect the bridge from errors that may occur during code development.

#### Motor Outputs:

Motor output terminals are labeled  $A_{out}$ ,  $B_{out}$ , and  $C_{out}$ . This output configuration can be used to drive a fractional horsepower 3 phase brushless DC motor, a reversible brush DC motor, or 3 brush DC motors unidirectionally. When driving a single brush DC motor, thermal performance is optimized by using  $A_{out}$  and  $C_{out}$  for the motor connections.

#### B+:

B+ is the motor power input connection. It is the only supply required. Acceptable input voltage range is 12.0 to 48 VDC. It is located on the output connector.

#### GND:

There are multiple ground connections. One of the two grounds on the output connector should be used as the power supply return.

#### Isense:

Isense is a current sense feedback voltage that appears on pin 15 of connector J2. It is derived from a .01 ohm low inductance surface mount sense resistor that is in series with the ground return. The voltage across this resistor is amplified with a gain of 25. Isense, therefore, represents motor current with a scale factor of 250 mV/Amp. Since only return current is measured, this output will not detect shorts from the motor outputs to ground.

#### Vbus:

Vbus is a bus voltage feedback signal that appears on pin 13 of connector J2. It is derived from a 37.4K/1.96K divider which scales B+ at a ratio of approximately 50 mV per volt. This is an unfiltered and unbuffered signal.

#### Vtemp:

A temperature output signal derived from a forward biased diode's  $V_F$  appears on connector J2 at pin 12. The diode, D11, is mounted such that it measures board temperature adjacent to power transistor Q12.

### Phase Voltage Feedback:

Phase voltage feedback signals Pa, Pb, & Pc are also included on feedback connector J2. They are located on pins 2, 4, and 6. These pins provide motor phase voltages divided down with the same 50 mV/Volt ratio as Vbus. They are also unfiltered and unbuffered signals.

## APPLICATION EXAMPLE

An application example shown in Figure 5 illustrates system

connections to an ASB124 control board and a Brushless DC motor. This arrangement can be run stand alone, or the ASB124 can be connected to an MMDS05 for code development. The two boards are designed such that the Drive and Feedback ribbon connectors line up. Ribbon cables are supplied with the ASB124 board. Once they are plugged in it is only a matter of connecting power supply, motor, and Hall sensor leads to get a system up and running.

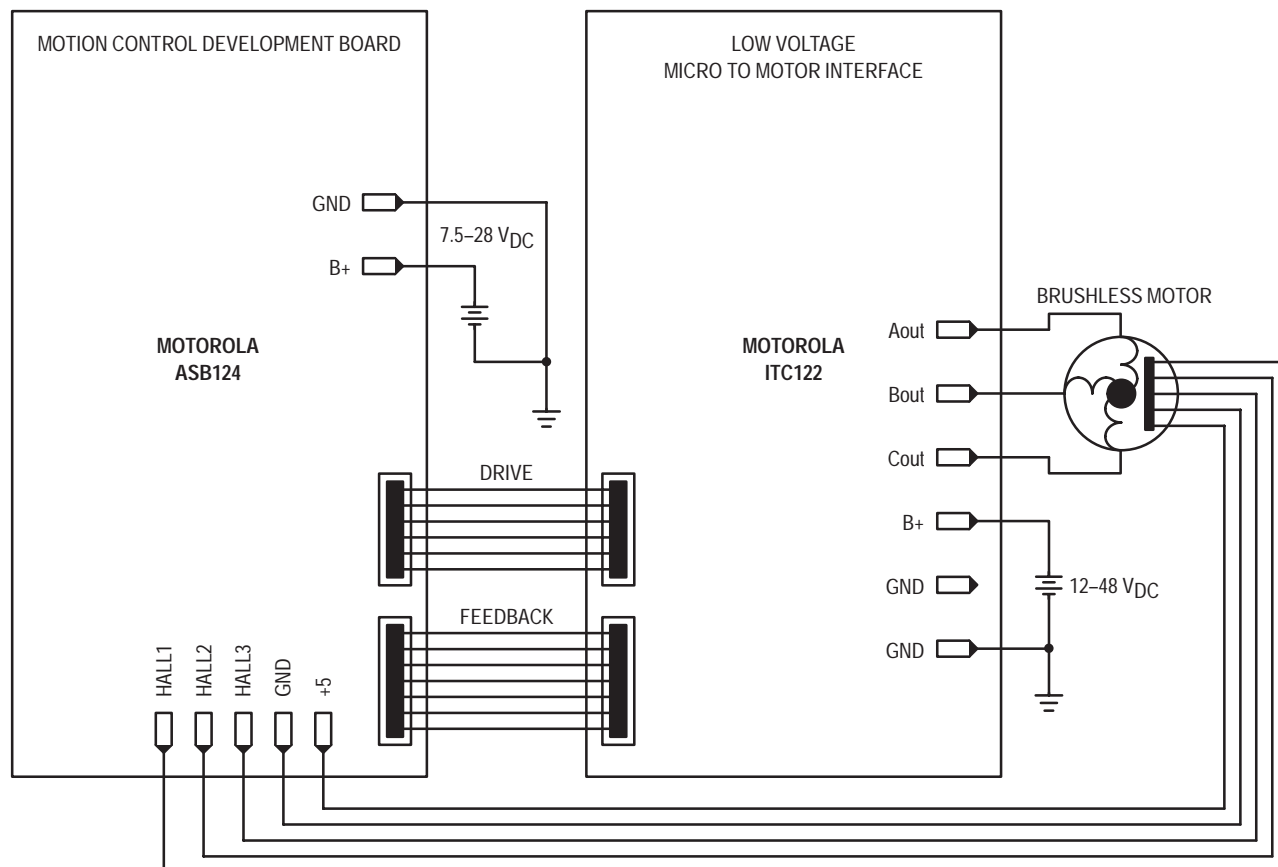

Figure 5. Application Example

An important application's consideration is pulse width modulation topology. The controller that is shown in Figure 5 pulse width modulates A<sub>top</sub>, B<sub>top</sub>, & C<sub>top</sub> inputs, and commutates A<sub>bot</sub>, B<sub>bot</sub>, & C<sub>bot</sub>. This configuration performs better from a power dissipation standpoint than its more commonly used alternative, namely lower half bridge pulse width modulation with upper half bridge commutation. When the upper half bridge is pulse width modulated, circulating currents flow through the lower r<sub>ds(on)</sub> and lower forward diode voltages of the N-Channel transistors. Since transition times for both P-Channel & N-Channel transistors are approximately the same, high side pulse width modulation is considerably more efficient. With more efficient operation, available output power to the motor is maximized.

## DESIGN CONSIDERATIONS

A block diagram that provides an overview of the design is

illustrated in Figure 6. Top and Bottom inputs for each phase are coupled to gate drive circuits through cross coupled NOR gates. This arrangement locks out the bottom input when both inputs for one phase are low, thereby adding robustness for lab use. If all six inputs are low, transistors A<sub>top</sub>, B<sub>top</sub>, and C<sub>top</sub> are turned on, which brakes the motor. This condition can occur when an ASB124 controller is powered down.

The output is a 3 phase bridge that is made from complimentary 30 amp surface mount MOSFET's. Gate drive for the N-Channel transistors is provided by MC33152 MOSFET drivers and for the P-Channels by a discrete circuit. A more detailed view of the gate drive circuits is shown in Figure 7. Both the P-Channel & N-Channel transistors have transition times targeted for approximately 200 nsec. This target allows high enough value gate drive resistors to somewhat soften diode snap, yet produces switching losses that are less than static losses at 23 KHz.

**AN1607**

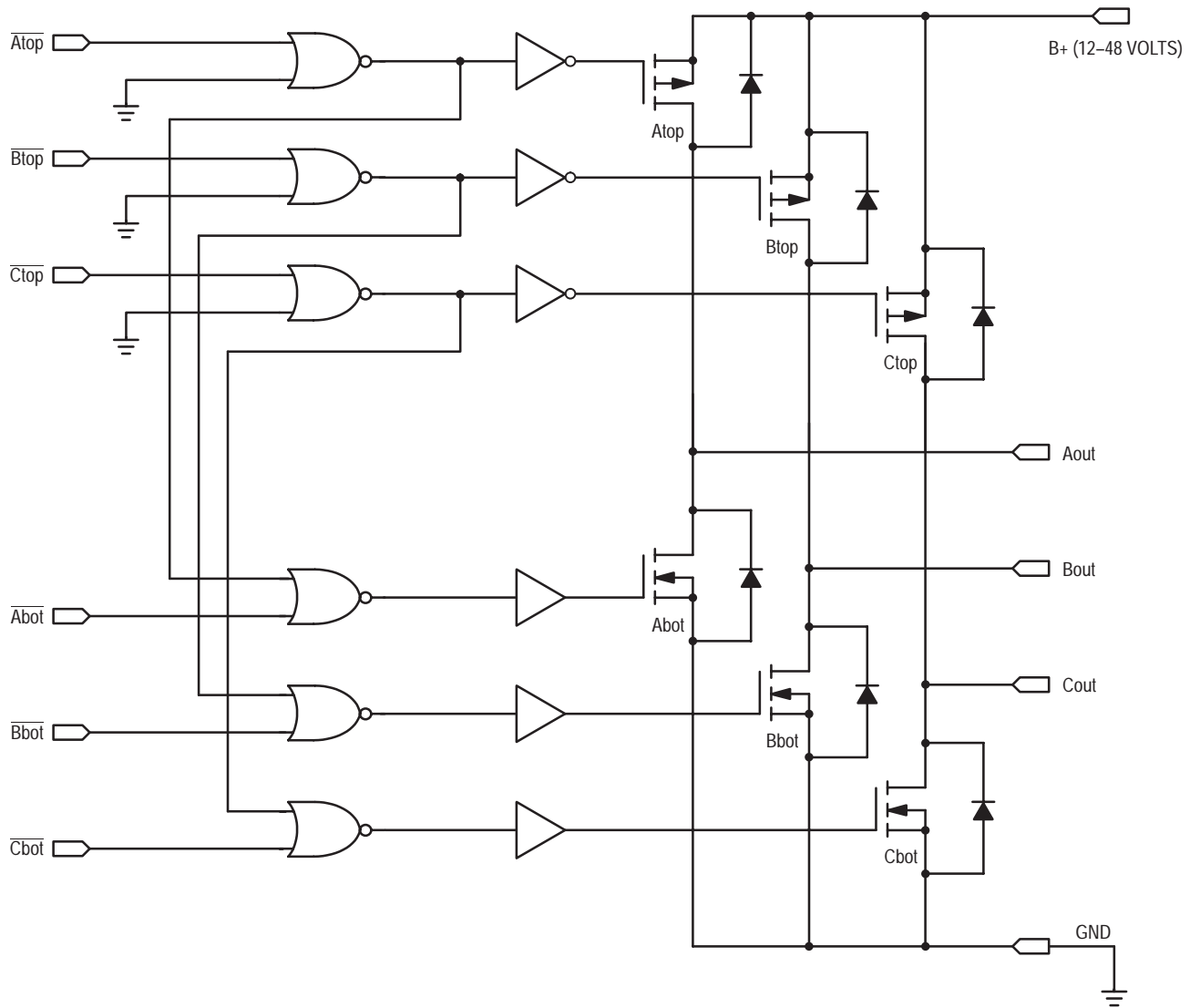

**Figure 6. Block Diagram**

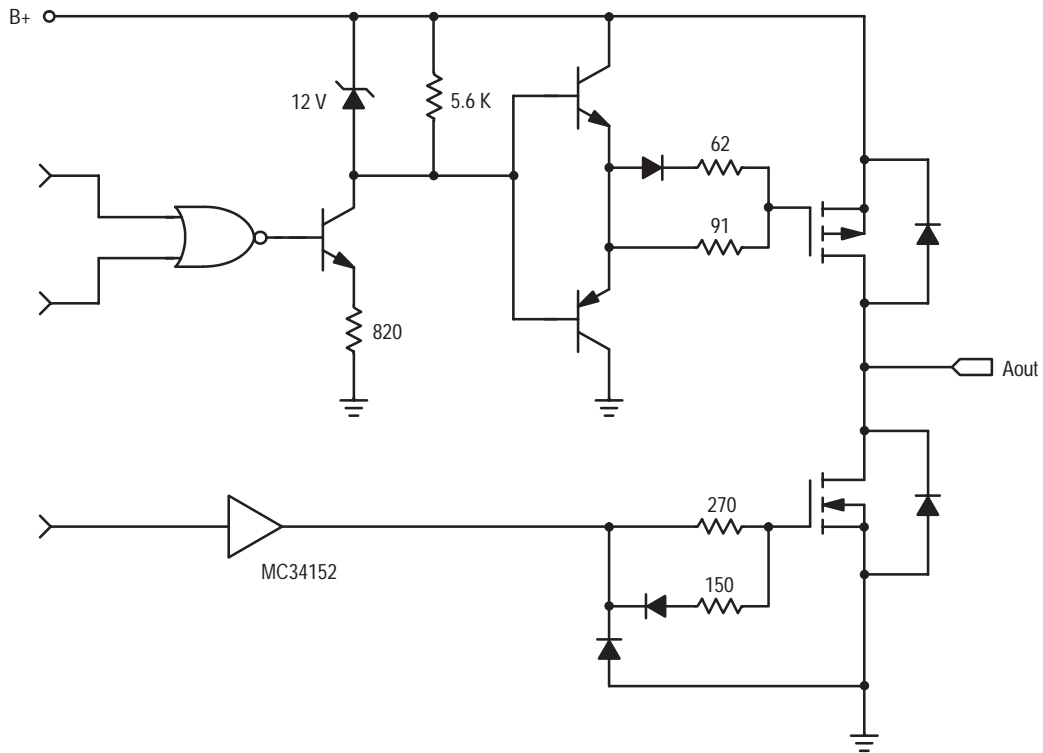

Figure 7. Gate Drive

**CONCLUSION**

The ITC122 Low Voltage Micro to Motor Interface is part of a motor control tool set that significantly reduces design and

development time. It accepts signals from an ASB124 Motion Control Development Board, and provides a 3 phase power output that is capable of supplying 4 amps from bus voltages up to 48 VDC.

# NOTES

# NOTES

Motorola reserves the right to make changes without further notice to any products herein. Motorola makes no warranty, representation or guarantee regarding the suitability of its products for any particular purpose, nor does Motorola assume any liability arising out of the application or use of any product or circuit, and specifically disclaims any and all liability, including without limitation consequential or incidental damages. "Typical" parameters which may be provided in Motorola data sheets and/or specifications can and do vary in different applications and actual performance may vary over time. All operating parameters, including "Typicals" must be validated for each customer application by customer's technical experts. Motorola does not convey any license under its patent rights nor the rights of others. Motorola products are not designed, intended, or authorized for use as components in systems intended for surgical implant into the body, or other applications intended to support or sustain life, or for any other application in which the failure of the Motorola product could create a situation where personal injury or death may occur. Should Buyer purchase or use Motorola products for any such unintended or unauthorized application, Buyer shall indemnify and hold Motorola and its officers, employees, subsidiaries, affiliates, and distributors harmless against all claims, costs, damages, and expenses, and reasonable attorney fees arising out of, directly or indirectly, any claim of personal injury or death associated with such unintended or unauthorized use, even if such claim alleges that Motorola was negligent regarding the design or manufacture of the part. Motorola and  are registered trademarks of Motorola, Inc. Motorola, Inc. is an Equal Opportunity/Affirmative Action Employer.

Mfax is a trademark of Motorola, Inc.

**How to reach us:**

**USA/EUROPE/Locations Not Listed:** Motorola Literature Distribution;  
P.O. Box 5405, Denver, Colorado 80217. 1-303-675-2140 or 1-800-441-2447

**JAPAN:** Nippon Motorola Ltd.; SPD, Strategic Planning Office, 141,  
4-32-1 Nishi-Gotanda, Shinagawa-ku, Tokyo, Japan. 81-3-5487-8488

**Customer Focus Center: 1-800-521-6274**

**Mfax™:** RMFAX0@email.sps.mot.com – TOUCHTONE 1-602-244-6609  
Motorola Fax Back System – US & Canada ONLY 1-800-774-1848  
– http://sps.motorola.com/mfax/

**ASIA/PACIFIC:** Motorola Semiconductors H.K. Ltd.; 8B Tai Ping Industrial Park,  
51 Ting Kok Road, Tai Po, N.T., Hong Kong. 852-26629298

**HOME PAGE:** <http://motorola.com/sps/>

**MOTOROLA**



LittleDiode supplies new, hard to find or obsolete electronic components and semiconductors all over the world.

With over two million different components listed you are sure to find the part you need.

Feel free to visit us today at our online store:

**[LittleDiode.com](http://LittleDiode.com)**

Looking forward to providing you with the best possible service.