

Features

- Epitaxial Die Construction
- Complementary PNP Type Available (BC857AT,BT,CT)
- Ultra-Small Surface Mount Package

Mechanical Data

- Case: SOT-523, Molded Plastic
- Terminals: Solderable per MIL-STD-202, Method 208
- Terminal Connections: See Diagram
- Weight: 0.002 grams (approx.)

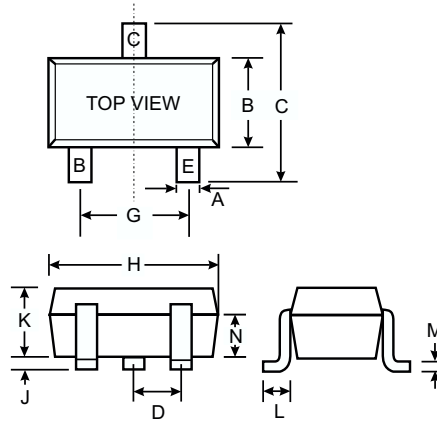

SOT-523			
Dim	Min	Max	Typ
A	0.15	0.30	0.22
B	0.75	0.85	0.80
C	1.45	1.75	1.60
D	—	—	0.50
G	0.90	1.10	1.00
H	1.50	1.70	1.60
J	0.00	0.10	0.05
K	0.60	0.80	0.75
L	0.10	0.30	0.22
M	0.10	0.20	0.12
N	0.45	0.65	0.50
All Dimensions in mm			

Type	Marking
BC847A	1E
BC847B	1F
BC847C	1M

Maximum Ratings @ $T_A = 25^\circ\text{C}$ unless otherwise specified

Characteristic	Symbol	Value	Unit
Collector-Base Voltage	V_{CBO}	50	V
Collector-Emitter Voltage	V_{CEO}	45	V
Emitter-Base Voltage	V_{EBO}	6.0	V
Collector Current	I_C	100	mA
Power Dissipation (Note 1)	P_d	150	mW
Thermal Resistance, Junction to Ambient	$R_{\theta JA}$	833	$^\circ\text{C/W}$
Operating and Storage Temperature Range	T_j, T_{STG}	-55 to +150	$^\circ\text{C}$

Ordering Information (Note 2)

Device	Packaging	Shipping
BC847AT-7	SOT-523	3000/Tape & Reel
BC847BT-7	SOT-523	3000/Tape & Reel
BC847CT-7	SOT-523	3000/Tape & Reel

- Notes: 1. Device mounted on FR-4 PC board with recommended pad layout.
 2. For Packaging Details, go to our website at <http://www.diodes.com/datasheets/ap02007.pdf>.

Electrical Characteristics @ $T_A = 25^\circ\text{C}$ unless otherwise specified

Characteristic	Symbol	Min	Typ	Max	Unit	Test Condition
DC Current Gain (Note 3)	Current Gain A B C h _{FE} Current Gain A B C	—	—	—	—	V _{CE} = 5.0V, I _C = 2.0mA
		—	150	—		
		—	270	—		
		110	—	220		
		200	290	450		
		420	520	800		
Collector-Emitter Saturation Voltage (Note 3)	V _{CE(SAT)}	—	—	250 600	mV	I _C = 10mA, I _B = 0.5mA I _C = 100mA, I _B = 5.0mA
Base-Emitter Saturation Voltage (Note 3)	V _{BE(SAT)}	—	700 900	—	mV	I _C = 10mA, I _B = 0.5mA I _C = 100mA, I _B = 5.0mA
Base-Emitter Voltage (Note 3)	V _{BE}	580 —	660 —	700 770	mV	V _{CE} = 5.0V, I _C = 2.0mA V _{CE} = 5.0V, I _C = 10mA
Collector-Emitter Cutoff Current (Note 3)	I _{CBO} I _{CBO}	—	—	15	nA μA	V _{CB} = 30V V _{CB} = 30V, T _A = 150°C
				5.0		
Gain Bandwidth Product	f _T	100	—	—	MHz	V _{CE} = 5.0V, I _C = 10mA, f = 100MHz
Output Capacitance	C _{OBO}	—	—	4.5	pF	V _{CB} = 10V, f = 1.0MHz
Noise Figure	BC847BT BC847CT	NF	—	10	dB	V _{CE} = 5V, R _S = 2.0kΩ, f = 1.0kHz, BW = 200Hz
				4.0		

Notes: 3. Short duration test pulse used to minimize self-heating effect.

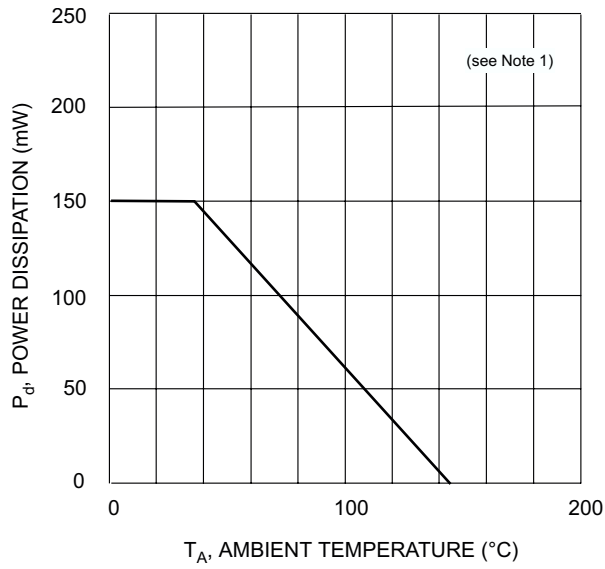

Fig. 1, Power Derating Curve

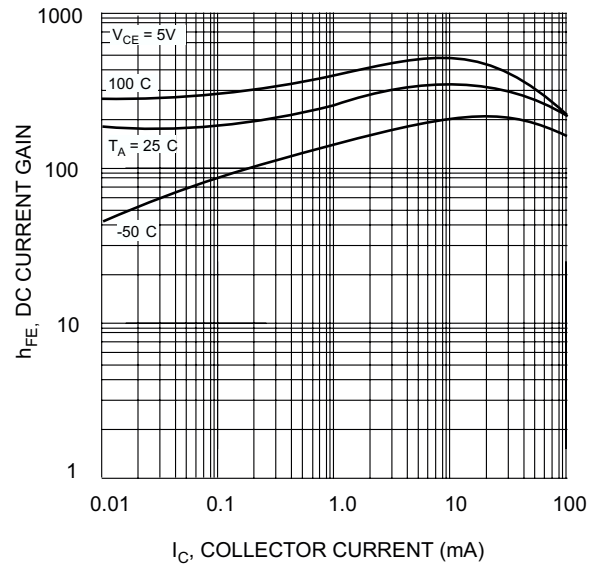

Fig. 2, DC Current Gain vs Collector Current

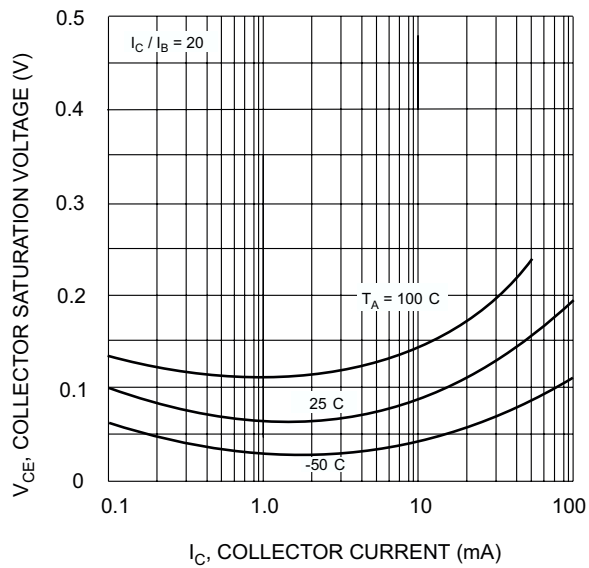

Fig. 3, Collector Saturation Voltage vs Collector Current

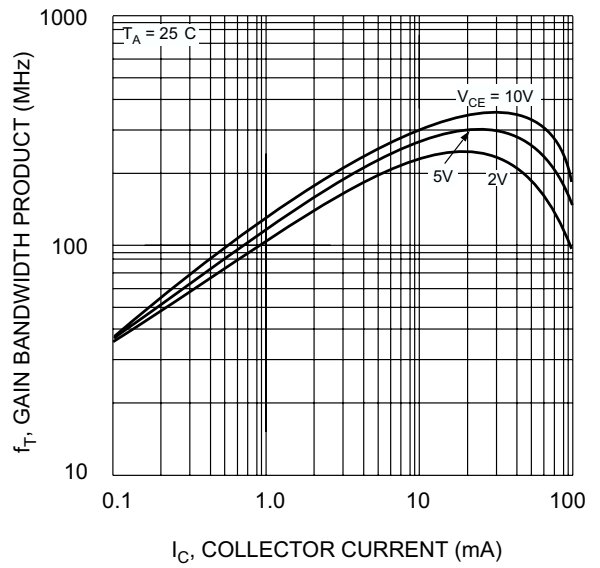

Fig. 4, Gain Bandwidth Product vs Collector Current

Notes: 1. Device mounted on FR-4 PC board with recommended pad layout.

This datasheet has been downloaded from:

www.DatasheetCatalog.com

Datasheets for electronic components.



LittleDiode supplies new, hard to find or obsolete electronic components and semiconductors all over the world.

With over two million different components listed you are sure to find the part you need.

Feel free to visit us today at our online store:

LittleDiode.com

Looking forward to providing you with the best possible service.