

# Video signal switcher

## BA7603 / BA7603F

The BA7603 and BA7603F are switching ICs developed for use in VCRs. Each contains three two-channel analog multi-plexers. The switches have sync-tip clamped inputs and are ideal for switching video signals.

●Applications

Video cassette recorders and televisions

●Features

- 1) Three 2-input / 1-output switches.
- 2) Sync-tip clamped inputs.
- 3) 5V power supply.
- 4) Low power consumption (62.5mW Typ.).
- 5) Excellent frequency characteristics (10MHz, 0dB Typ.).
- 6) Wide dynamic range (2.9V<sub>P-P</sub> Typ.).
- 7) Fast switching speed (50ns Typ.).

●Absolute maximum ratings (Ta = 25°C)

Parameter	Symbol	Limits	Unit
Power supply voltage	V <sub>CC</sub>	9	V
Power dissipation	P <sub>d</sub>	500*	mW
Operating temperature	T <sub>opr</sub>	- 40 ~ + 85	°C
Storage temperature	T <sub>stg</sub>	- 55 ~ + 125	°C

\* Reduced by 5.0mW for each increase in Ta of 1°C over 25°C.

●Block diagram

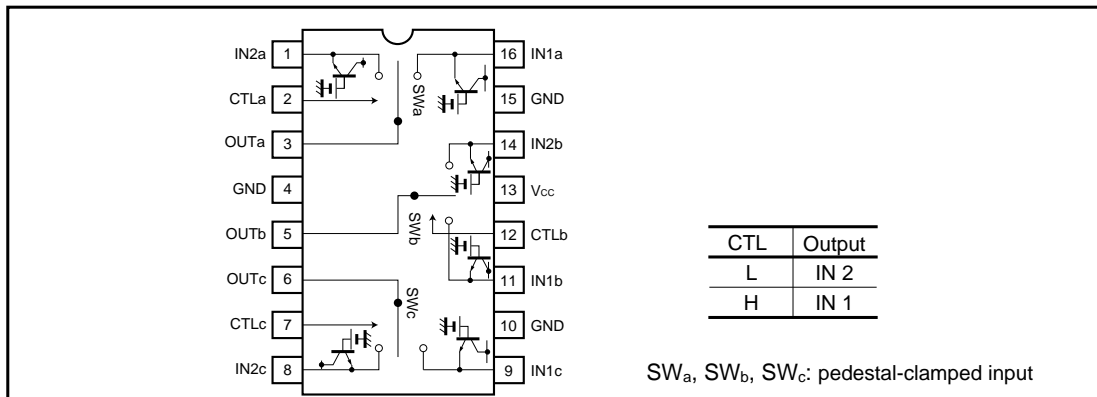

●Equivalent circuits

SWa, SWb, SWc

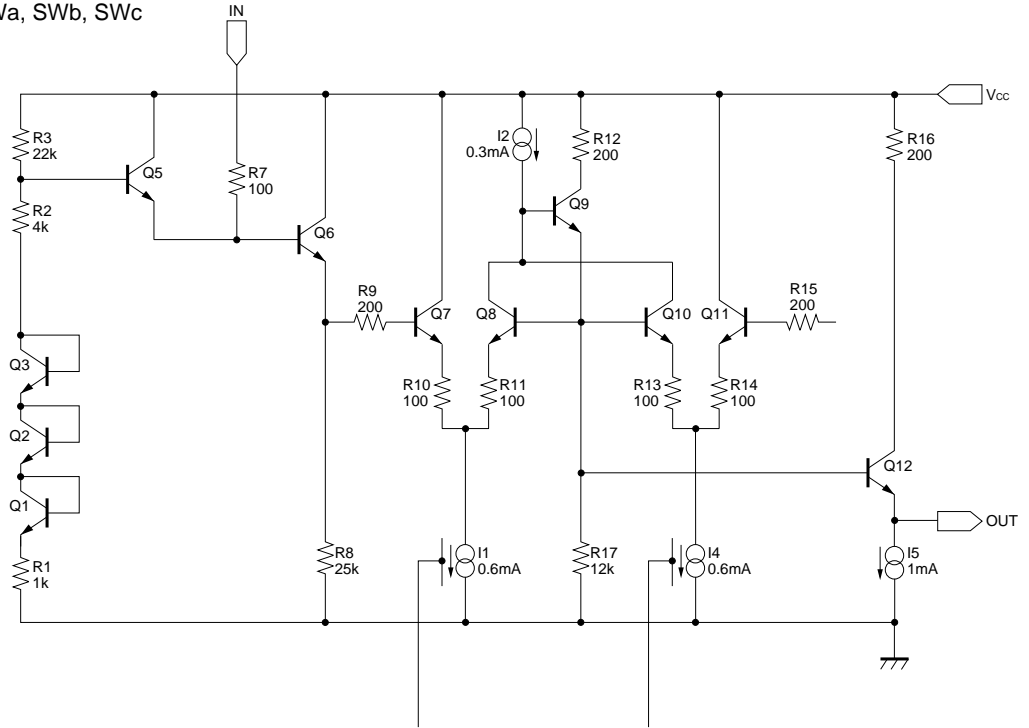

CTL

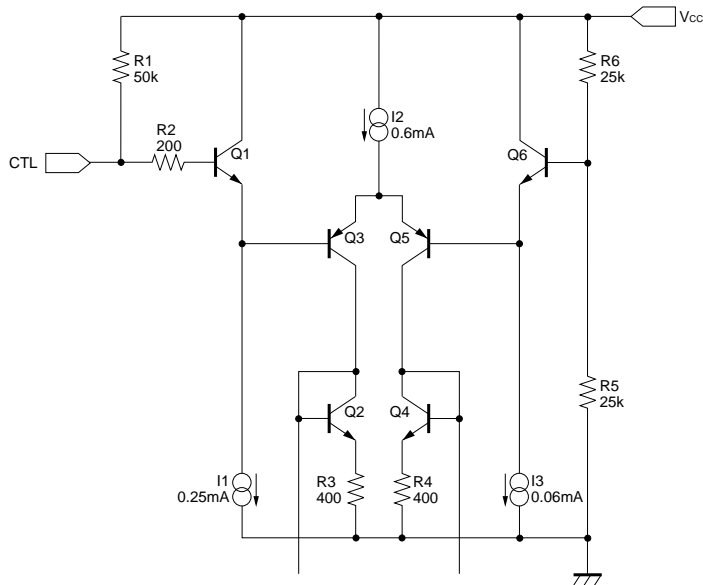

●Electrical characteristics (unless otherwise noted Ta = 25°C and Vcc = 5V)

Parameter	Symbol	Min.	Typ.	Max.	Unit	Conditions
Operating voltage	V <sub>CC</sub>	4.5	5.0	5.5	V	—
Supply current	I <sub>CC</sub>	—	13.0	20.0	mA	—
Maximum output level	V <sub>om</sub>	2.7	2.9	—	V <sub>P-P</sub>	f = 1kHz, THD = 0.5%
Voltage gain	G <sub>v</sub>	-0.5	0	0.5	dB	f = 1MHz, V <sub>IN</sub> = 1V <sub>P-P</sub>
Interchannel crosstalk	C <sub>T</sub>	—	-65	—	dB	f = 4.43MHz, V <sub>IN</sub> = 1V <sub>P-P</sub>
Frequency characteristics	G <sub>f</sub>	-3	0	1	dB	10MHz / 1MHz, V = 1V <sub>P-P</sub>
CTL pin switch level	V <sub>TH</sub>	2.0	2.5	3.0	V	—

\* Refer to the measurement circuit given in Fig. 1.

●Reference data

Pin DC voltages (reference values)

Units: Vdc

Pin No.	DC voltage	Pin No.	DC voltage
1	2.05	9	2.05
2	4.91	10	0
3	0.65	11	2.05
4	0	12	4.91
5	0.65	13	5.00
6	0.65	14	2.05
7	4.91	15	0
8	2.05	16	2.05

Electrical characteristics

Parameter	Min.	Typ.	Max.	Unit
Sync tip clamp level	0.49	0.65	0.80	Vdc
Input impedance (with clamp)	—	1.7M	—	Ω
Output impedance	—	30	—	Ω

The input coupling capacitor values should be 0.1μF to 1μF.



## ● Measurement conditions

Parameter		Symbol	Switch settings									Measurement method
			S <sub>1a</sub>	S <sub>2a</sub>	S <sub>3a</sub>	S <sub>1b</sub>	S <sub>2b</sub>	S <sub>3b</sub>	S <sub>1c</sub>	S <sub>2c</sub>	S <sub>3c</sub>	
Current dissipation		I <sub>CC</sub>	2	2	2	2	2	2	2	2	2	
Maximum output level	IN1a	V <sub>om</sub>	3	2	2	2	2	2	2	2	2	f = 1kHz, THD = 0.5% Note 1
	IN2a	V <sub>om</sub>	2	3	3	2	2	2	2	2	2	
	IN1b	V <sub>om</sub>	2	2	2	3	2	2	2	2	2	
	IN2b	V <sub>om</sub>	2	2	2	2	3	3	2	2	2	
	IN1C	V <sub>om</sub>	2	2	2	2	2	2	3	2	2	
	IN2C	V <sub>om</sub>	2	2	2	2	2	2	2	3	3	
Voltage gain	IN1a	G <sub>V</sub>	3	2	2	2	2	2	2	2	2	f = 1kHz, V = 1V <sub>P-P</sub> Note 2
	IN2a	G <sub>V</sub>	2	3	3	2	2	2	2	2	2	
	IN1b	G <sub>V</sub>	2	2	2	3	2	2	2	2	2	
	IN2b	G <sub>V</sub>	2	2	2	2	3	3	2	2	2	
	IN1c	G <sub>V</sub>	2	2	2	2	2	2	3	2	2	
	IN2c	G <sub>V</sub>	2	2	2	2	2	2	2	3	3	
Inter-channel crosstalk	IN1a	C <sub>T</sub>	2	3	2	2	2	2	2	2	2	f = 4.43MHz, V = 1V <sub>P-P</sub> Note 3
	IN2a	C <sub>T</sub>	3	2	3	2	2	2	2	2	2	
	IN1b	C <sub>T</sub>	2	2	2	2	3	2	2	2	2	
	IN2b	C <sub>T</sub>	2	2	2	3	2	3	2	2	2	
	IN1c	C <sub>T</sub>	2	2	2	2	2	2	2	3	2	
	IN2c	C <sub>T</sub>	2	2	2	2	2	2	3	2	3	
Frequency characteristic	IN1a	G <sub>f</sub>	3	2	2	2	2	2	2	2	2	f = 10MHz / f = 1MHz, V = 1V <sub>P-P</sub> Note 4
	IN2a	G <sub>f</sub>	2	3	3	2	2	2	2	2	2	
	IN1b	G <sub>f</sub>	2	2	2	3	2	2	2	2	2	
	IN2b	G <sub>f</sub>	2	2	2	2	3	3	2	2	2	
	IN1c	G <sub>f</sub>	2	2	2	2	2	2	3	2	2	
	IN2c	G <sub>f</sub>	2	2	2	2	2	2	2	3	3	
CTL pin switching level	CTLa	V <sub>TH</sub>	1	2	1	2	2	2	2	2	2	Note 5
	CTLb	V <sub>TH</sub>	2	2	2	1	2	1	2	2	2	
	CTLc	V <sub>TH</sub>	2	2	2	2	2	2	1	2	1	

Note 1: Connect a distortion meter to the output, and input a f = 1kHz sine wave. Adjust the output level until the output distortion is 0.5%.

This output voltage at this time is the maximum output level V<sub>om</sub> (V<sub>P-P</sub>).

Note 2: Input a 1V<sub>P-P</sub>, 1MHz sine wave. The voltage gain is given by  $G_V = 20 \log (V_{OUT} / V_{IN})$ .

Note 3: Input a 1V<sub>P-P</sub>, 4.43MHz sine wave. The interchannel crosstalk is given by  $C_T = 20 \log (V_{OUT} / V_{IN})$ .

Note 4: Input 1V<sub>P-P</sub>, 1MHz and 10MHz sine waves. The frequency characteristic is given by  $G_f = 20 \log (V_{OUT} (f = 10\text{MHz}) / V_{OUT} (f = 1\text{MHz}))$ .

Note 5: Input a 1V<sub>P-P</sub>, 1MHz sine wave. Reduce the CTL pin voltage from V<sub>CC</sub>.

The CTL pin switching level (V<sub>TH</sub>) is the CTL pin voltage at which the V<sub>OUT</sub> level drops below 20mV<sub>P-P</sub>.

●External dimensions (Units: mm)

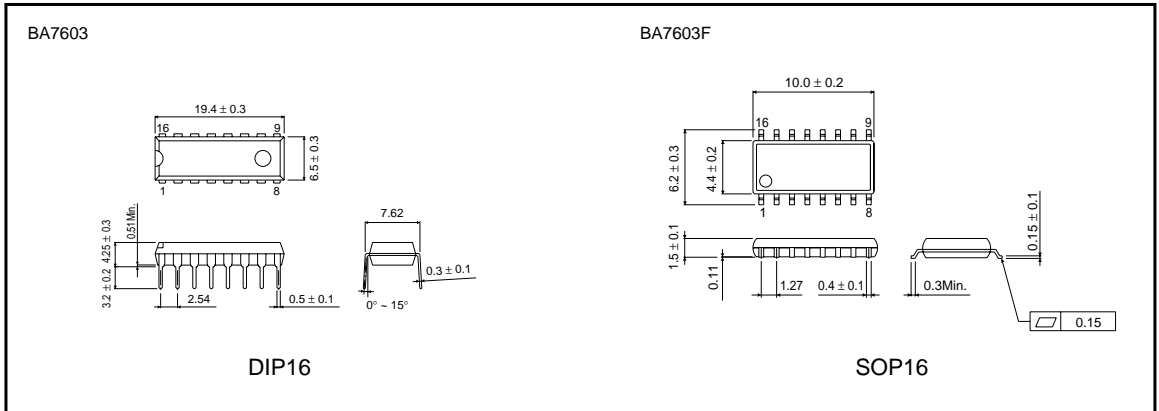

This datasheet has been downloaded from:

[www.DatasheetCatalog.com](http://www.DatasheetCatalog.com)

Datasheets for electronic components.



LittleDiode supplies new, hard to find or obsolete electronic components and semiconductors all over the world.

With over two million different components listed you are sure to find the part you need.

Feel free to visit us today at our online store:

[LittleDiode.com](http://LittleDiode.com)

Looking forward to providing you with the best possible service.