

Features

- Fast Read Access Time - 70 ns
- Automatic Page Write Operation
 - Internal Address and Data Latches for 64-Bytes
 - Internal Control Timer
- Fast Write Cycle Times
 - Page Write Cycle Time: 3 ms or 10 ms Maximum
 - 1 to 64-Byte Page Write Operation
- Low Power Dissipation
 - 80 mA Active Current
 - 3 mA Standby Current
- Hardware and Software Data Protection
- DATA Polling for End of Write Detection
- High Reliability CMOS Technology
 - Endurance: 10^4 or 10^5 Cycles
 - Data Retention: 10 Years
- Single $5V \pm 10\%$ Supply
- CMOS and TTL Compatible Inputs and Outputs
- JEDEC Approved Byte-Wide Pinout
- Full Military, Commercial, and Industrial Temperature Ranges

256 (32K x 8)
High Speed
CMOS
E²PROM

Description

The AT28HC256 is a high-performance Electrically Erasable and Programmable Read Only Memory. Its 256K of memory is organized as 32,768 words by 8 bits. Manufactured with Atmel's advanced nonvolatile CMOS technology, the AT28HC256 offers access times to 70 ns with power dissipation of just 440 mW. When the AT28HC256 is deselected, the standby current is less than 5 mA.

(continued)

Pin Configurations

| Pin Name | Function |
|-----------------|---------------------|
| A0 - A14 | Addresses |
| \overline{CE} | Chip Enable |
| \overline{OE} | Output Enable |
| \overline{WE} | Write Enable |
| I/O0 - I/O7 | Data Inputs/Outputs |
| NC | No Connect |
| DC | Don't Connect |

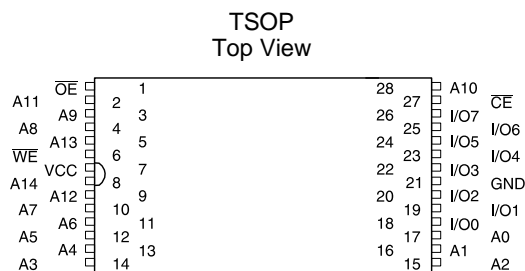

PGA
Top View

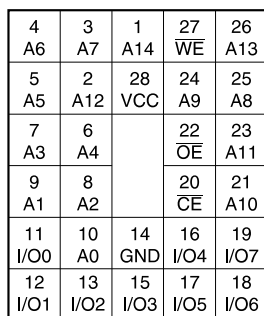

CERDIP, PDIP,
FLATPACK
Top View

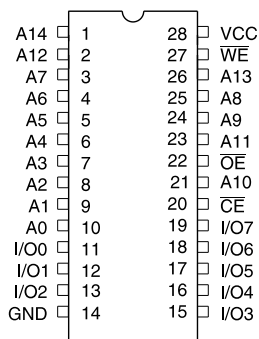

LCC, PLCC
Top View

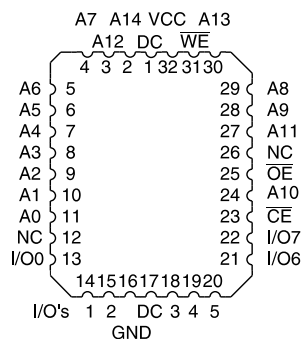

Note: PLCC package pins 1 and 17 are DON'T CONNECT.

0007F

Description (Continued)

The AT28HC256 is accessed like a Static RAM for the read or write cycle without the need for external components. The device contains a 64-byte page register to allow writing of up to 64-bytes simultaneously. During a write cycle, the address and 1 to 64-bytes of data are internally latched, freeing the addresses and data bus for other operations. Following the initiation of a write cycle, the device will automatically write the latched data using an internal control timer. The end of a write cycle can be detected by $\overline{\text{DATA}}$ polling of I/O7. Once the end of a write cycle has been detected a new access for a read or write can begin.

Atmel's 28HC256 has additional features to ensure high quality and manufacturability. The device utilizes internal error correction for extended endurance and improved data retention characteristics. An optional software data protection mechanism is available to guard against inadvertent writes. The device also includes an extra 64-bytes of E²PROM for device identification or tracking.

Block Diagram

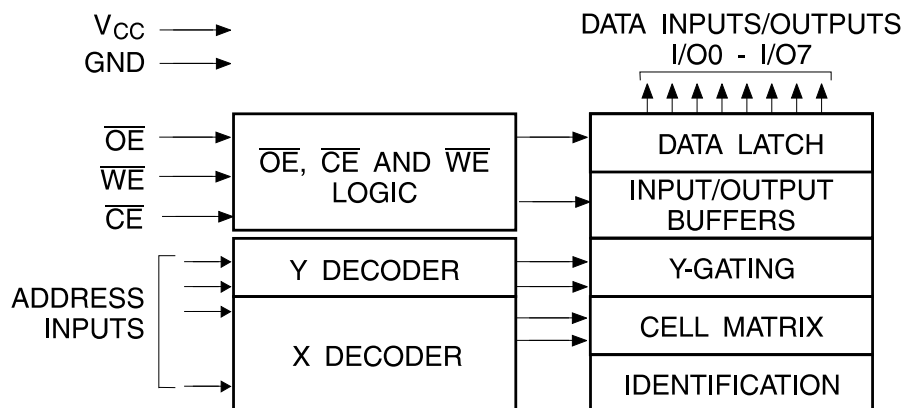

Absolute Maximum Ratings*

| | |
|---|--------------------------|
| Temperature Under Bias..... | -55°C to +125°C |
| Storage Temperature..... | -65°C to +150°C |
| All Input Voltages (including NC Pins) with Respect to Ground | -0.6V to +6.25V |
| All Output Voltages with Respect to Ground | -0.6V to $V_{CC} + 0.6V$ |
| Voltage on $\overline{\text{OE}}$ and A9 with Respect to Ground | -0.6V to +13.5V |

*NOTICE: Stresses beyond those listed under "Absolute Maximum Ratings" may cause permanent damage to the device. This is a stress rating only and functional operation of the device at these or any other conditions beyond those indicated in the operational sections of this specification is not implied. Exposure to absolute maximum rating conditions for extended periods may affect device reliability.

Device Operation

READ: The AT28HC256 is accessed like a Static RAM. When \overline{CE} and \overline{OE} are low and \overline{WE} is high, the data stored at the memory location determined by the address pins is asserted on the outputs. The outputs are put in the high impedance state when either \overline{CE} or \overline{OE} is high. This dual-line control gives designers flexibility in preventing bus contention in their system.

BYTE WRITE: A low pulse on the \overline{WE} or \overline{CE} input with \overline{CE} or \overline{WE} low (respectively) and \overline{OE} high initiates a write cycle. The address is latched on the falling edge of \overline{CE} or \overline{WE} , whichever occurs last. The data is latched by the first rising edge of \overline{CE} or \overline{WE} . Once a byte write has been started it will automatically time itself to completion. Once a programming operation has been initiated and for the duration of t_{WC} , a read operation will effectively be a polling operation.

PAGE WRITE: The page write operation of the AT28HC256 allows 1 to 64-bytes of data to be written into the device during a single internal programming period. A page write operation is initiated in the same manner as a byte write; the first byte written can then be followed by 1 to 63 additional bytes. Each successive byte must be written within 150 μ s (t_{BLC}) of the previous byte. If the t_{BLC} limit is exceeded the AT28HC256 will cease accepting data and commence the internal programming operation. All bytes during a page write operation must reside on the same page as defined by the state of the A6 - A14 inputs. That is, for each \overline{WE} high to low transition during the page write operation, A6 - A14 must be the same.

The A0 to A5 inputs are used to specify which bytes within the page are to be written. The bytes may be loaded in any order and may be altered within the same load period. Only bytes which are specified for writing will be written; unnecessary cycling of other bytes within the page does not occur.

DATA POLLING: The AT28HC256 features \overline{DATA} Polling to indicate the end of a write cycle. During a byte or page write cycle an attempted read of the last byte written will result in the complement of the written data to be presented on I/O7. Once the write cycle has been completed, true data is valid on all outputs, and the next write cycle may begin. \overline{DATA} Polling may begin at anytime during the write cycle.

TOGGLE BIT: In addition to \overline{DATA} Polling the AT28HC256 provides another method for determining the end of a write cycle. During the write operation, successive attempts to read data from the device will result in I/O6 toggling between one and zero. Once the write has completed, I/O6 will stop toggling and valid data will be read. Testing the toggle bit may begin at any time during the write cycle.

DATA PROTECTION: If precautions are not taken, inadvertent writes to any 5-volt-only nonvolatile memory may occur during transition of the host system power supply. Atmel has incorporated both hardware and software features that will protect the memory against inadvertent writes.

HARDWARE PROTECTION: Hardware features protect against inadvertent writes to the AT28HC256 in the following ways: (a) V_{CC} sense - if V_{CC} is below 3.8V (typical) the write function is inhibited; (b) V_{CC} power-on delay - once V_{CC} has reached 3.8V the device will automatically time out 5 ms (typical) before allowing a write; (c) write inhibit - holding any one of \overline{OE} low, \overline{CE} high or \overline{WE} high inhibits write cycles; (d) noise filter - pulses of less than 15 ns (typical) on the \overline{WE} or \overline{CE} inputs will not initiate a write cycle.

SOFTWARE DATA PROTECTION: A software controlled data protection feature has been implemented on the AT28HC256. When enabled, the software data protection (SDP), will prevent inadvertent writes. The SDP feature may be enabled or disabled by the user; the AT28HC256 is shipped from Atmel with SDP disabled.

SDP is enabled by the host system issuing a series of three write commands; three specific bytes of data are written to three specific addresses (refer to Software Data Protection Algorithm). After writing the 3-byte command sequence and after t_{WC} the entire AT28HC256 will be protected against inadvertent write operations. It should be noted, that once protected the host may still perform a byte or page write to the AT28HC256. This is done by preceding the data to be written by the same 3-byte command sequence.

Once set, SDP will remain active unless the disable command sequence is issued. Power transitions do not disable SDP and SDP will protect the AT28HC256 during power-up and power-down conditions. All command sequences must conform to the page write timing specifications. It should also be noted that the data in the enable and disable command sequences is not written to the device and the memory addresses used in the sequence may be written with data in either a byte or page write operation.

After setting SDP, any attempt to write to the device without the three byte command sequence will start the internal write timers. No data will be written to the device; however, for the duration of t_{WC} , read operations will effectively be polling operations.

(continued)



Device Operation (Continued)

DEVICE IDENTIFICATION: An extra 64-bytes of E²PROM memory are available to the user for device identification. By raising A9 to 12V ± 0.5V and using address locations 7FC0H to 7FFFH the additional bytes may be written to or read from in the same manner as the regular memory array.

OPTIONAL CHIP ERASE MODE: The entire device can be erased using a 6-byte software code. Please see Software Chip Erase application note for details.

DC and AC Operating Range

| | | AT28HC256-70 | AT28HC256-90 | AT28HC256-12 |
|------------------------------|------|--------------|---------------|---------------|
| Operating Temperature (Case) | Com. | 0°C - 70°C | 0°C - 70°C | 0°C - 70°C |
| | Ind. | -40°C - 85°C | -40°C - 85°C | -40°C - 85°C |
| | Mil. | | -55°C - 125°C | -55°C - 125°C |
| V _{CC} Power Supply | | 5V ± 10% | 5V ± 10% | 5V ± 10% |

Operating Modes

| Mode | \overline{CE} | \overline{OE} | \overline{WE} | I/O |
|-----------------------|-----------------|-------------------------------|-----------------|------------------|
| Read | V _{IL} | V _{IL} | V _{IH} | D _{OUT} |
| Write ⁽²⁾ | V _{IL} | V _{IH} | V _{IL} | D _{IN} |
| Standby/Write Inhibit | V _{IH} | X ⁽¹⁾ | X | High Z |
| Write Inhibit | X | X | V _{IH} | |
| Write Inhibit | X | V _{IL} | X | |
| Output Disable | X | V _{IH} | X | High Z |
| Chip Erase | V _{IL} | V _H ⁽³⁾ | V _{IL} | High Z |

Notes: 1. X can be V_{IL} or V_{IH}.

2. Refer to AC Programming Waveforms.

3. V_H = 12.0V ± 0.5V.

DC Characteristics

| Symbol | Parameter | Condition | Min | Max | Units |
|------------------|--------------------------------------|---|-------------------|-----|-------|
| I _{LI} | Input Load Current | V _{IN} = 0V to V _{CC} + 1V | | 10 | μA |
| I _{LO} | Output Leakage Current | V _{I/O} = 0V to V _{CC} | | 10 | μA |
| I _{SB1} | V _{CC} Standby Current TTL | \overline{CE} = 2.0V to V _{CC} + 1V | AT28HC256-90, -12 | 3 | mA |
| | | | AT28HC256-70 | 60 | mA |
| I _{SB2} | V _{CC} Standby Current CMOS | \overline{CE} = -3.0V to V _{CC} + 1V | AT28HC256-90, -12 | 300 | μA |
| I _{CC} | V _{CC} Active Current | f = 5 MHz; I _{OUT} = 0 mA | | 80 | mA |
| V _{IL} | Input Low Voltage | | | 0.8 | V |
| V _{IH} | Input High Voltage | | 2.0 | | V |
| V _{OL} | Output Low Voltage | I _{OL} = 6.0 mA | | .45 | V |
| V _{OH} | Output High Voltage | I _{OH} = -4 mA | 2.4 | | V |

AC Read Characteristics

| Symbol | Parameter | AT28HC256-70 | | AT28C256-90 | | AT28HC256-12 | | Units |
|------------------|---|--------------|-----|-------------|-----|--------------|-----|-------|
| | | Min | Max | Min | Max | Min | Max | |
| t_{ACC} | Address to Output Delay | | 70 | | 90 | | 120 | ns |
| $t_{CE}^{(1)}$ | \overline{CE} to Output Delay | | 70 | | 90 | | 120 | ns |
| $t_{OE}^{(2)}$ | \overline{OE} to Output Delay | 0 | 35 | 0 | 40 | 0 | 50 | ns |
| $t_{DF}^{(3,4)}$ | \overline{CE} or \overline{OE} to Output Float | 0 | 35 | 0 | 40 | 0 | 50 | ns |
| t_{OH} | Output Hold from \overline{OE} , \overline{CE} or Address, whichever occurred first | 0 | | 0 | | 0 | | ns |

AC Read Waveforms (1, 2, 3, 4)

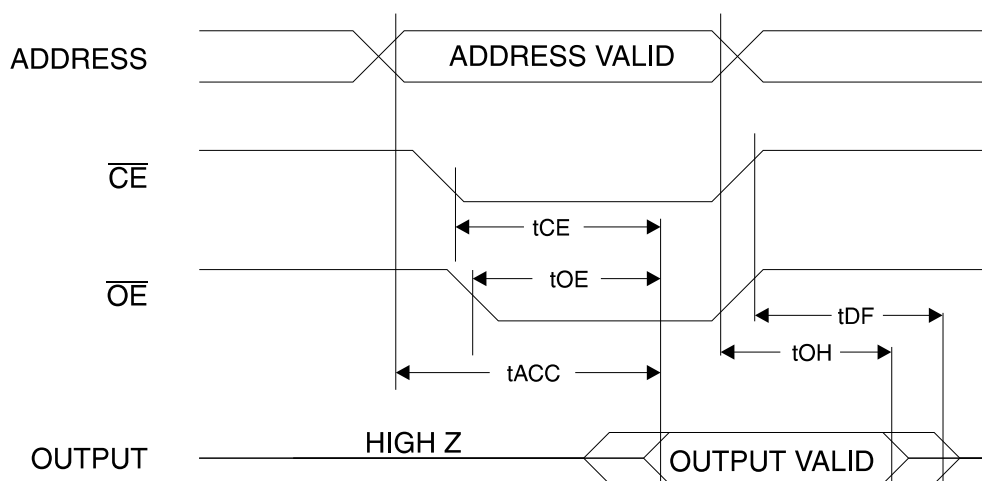

- Notes:
- \overline{CE} may be delayed up to $t_{ACC} - t_{CE}$ after the address transition without impact on t_{ACC} .
 - \overline{OE} may be delayed up to $t_{CE} - t_{OE}$ after the falling edge of \overline{CE} without impact on t_{CE} or by $t_{ACC} - t_{OE}$ after an address change without impact on t_{ACC} .

- t_{DF} is specified from \overline{OE} or \overline{CE} whichever occurs first ($C_L = 5 \text{ pF}$).
- This parameter is characterized and is not 100% tested.

Input Test Waveforms and Measurement Level

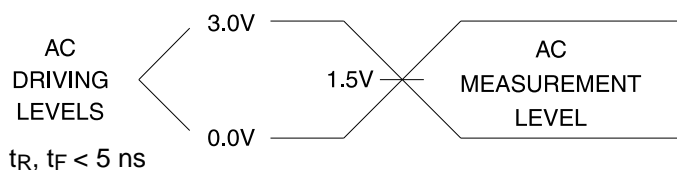

Output Test Load

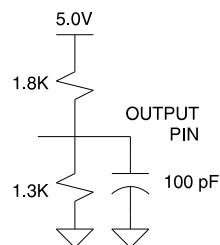

Pin Capacitance ($f = 1 \text{ MHz}$, $T = 25^\circ\text{C}$) (1)

| | Typ | Max | Units | Conditions |
|-----------|-----|-----|-------|----------------|
| C_{IN} | 4 | 6 | pF | $V_{IN} = 0V$ |
| C_{OUT} | 8 | 12 | pF | $V_{OUT} = 0V$ |

Note: 1. This parameter is characterized and is not 100% tested.

AC Write Characteristics

| Symbol | Parameter | Min | Max | Units |
|-------------------|--|-------------------|-----|-------|
| t_{AS}, t_{OES} | Address, \overline{OE} Set-up Time | 0 | | ns |
| t_{AH} | Address Hold Time | 50 | | ns |
| t_{CS} | Chip Select Set-up Time | 0 | | ns |
| t_{CH} | Chip Select Hold Time | 0 | | ns |
| t_{WP} | Write Pulse Width (\overline{WE} or \overline{CE}) | 100 | | ns |
| t_{DS} | Data Set-up Time | 50 | | ns |
| t_{DH}, t_{OEH} | Data, \overline{OE} Hold Time | 0 | | ns |
| t_{DV} | Time to Data Valid | NR ⁽¹⁾ | | |

Note: 1. NR = No Restriction

AC Write Waveforms

\overline{WE} Controlled

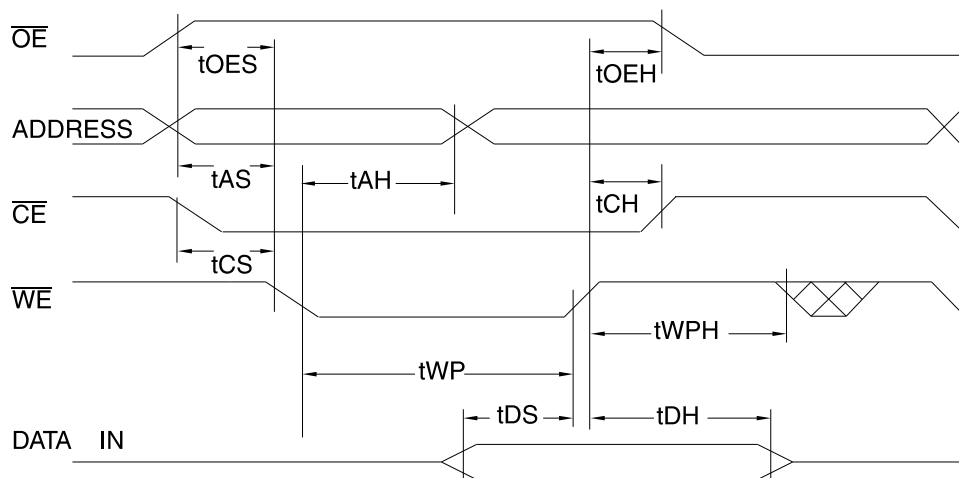

\overline{CE} Controlled

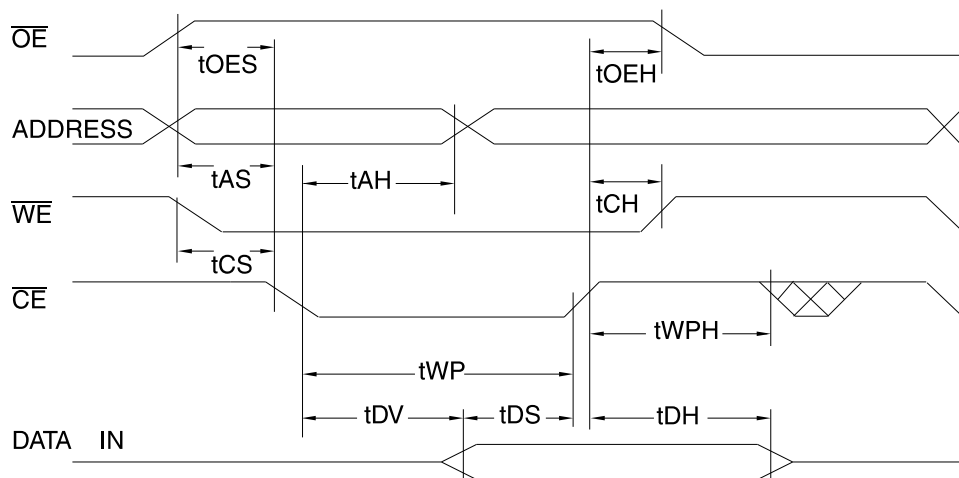

Page Mode Write Characteristics

| Symbol | Parameter | Min | Typ | Max | Units |
|------------------|------------------------|------------|-----|-----|-------|
| t _{WC} | Write Cycle Time | AT28HC256 | 5 | 10 | ms |
| | | AT28HC256F | 2 | 3.0 | ms |
| t _{AS} | Address Set-up Time | 0 | | | ns |
| t _{AH} | Address Hold Time | 50 | | | ns |
| t _{DS} | Data Set-up Time | 50 | | | ns |
| t _{DH} | Data Hold Time | 0 | | | ns |
| t _{WP} | Write Pulse Width | 100 | | | ns |
| t _{BLC} | Byte Load Cycle Time | | | 150 | μs |
| t _{WPH} | Write Pulse Width High | 50 | | | ns |

Page Mode Write Waveforms (1, 2)

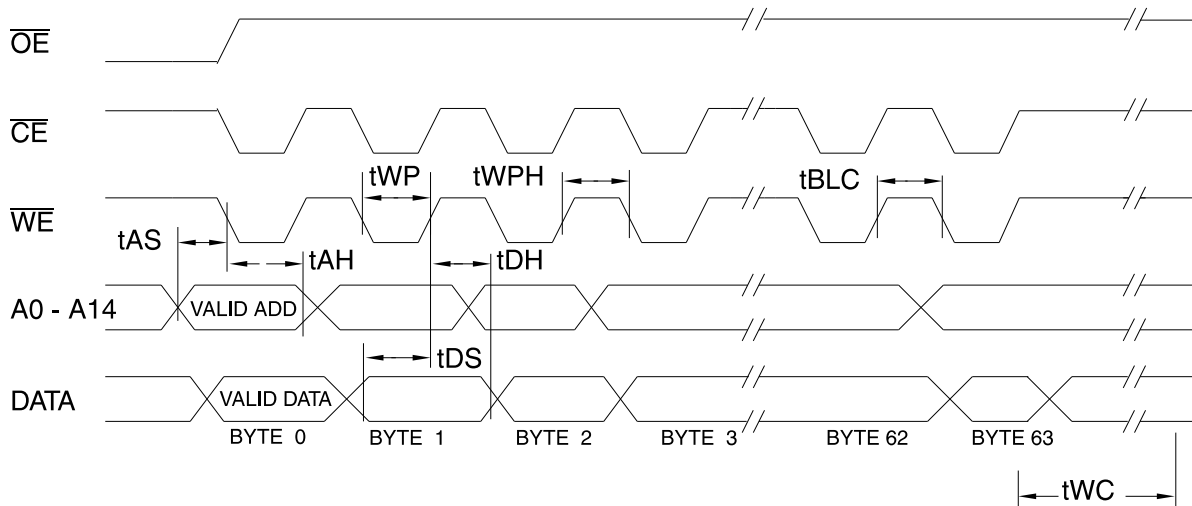

- Notes: 1. A_6 through A_{14} must specify the same page address during each high to low transition of \overline{WE} (or \overline{CE}).
 2. \overline{OE} must be high only when \overline{WE} and \overline{CE} are both low.

Chip Erase Waveforms

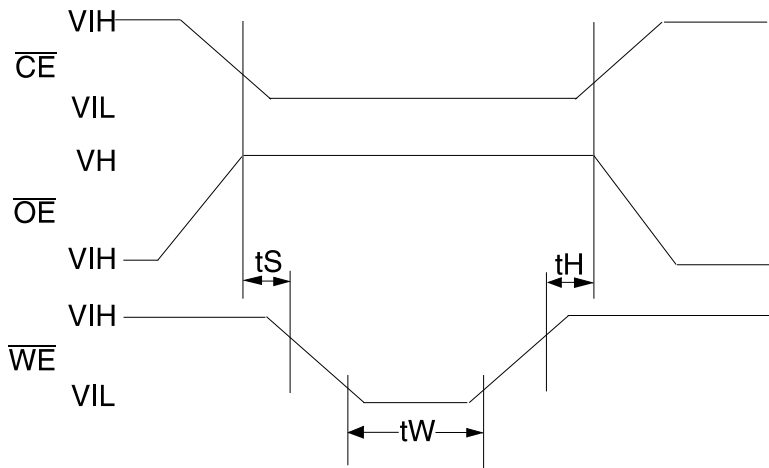

$t_S = t_H = 5 \mu\text{sec (min.)}$
 $t_W = 10 \text{ msec (min.)}$
 $V_H = 12.0V \pm 0.5V$

Software Data Protection Enable Algorithm ⁽¹⁾

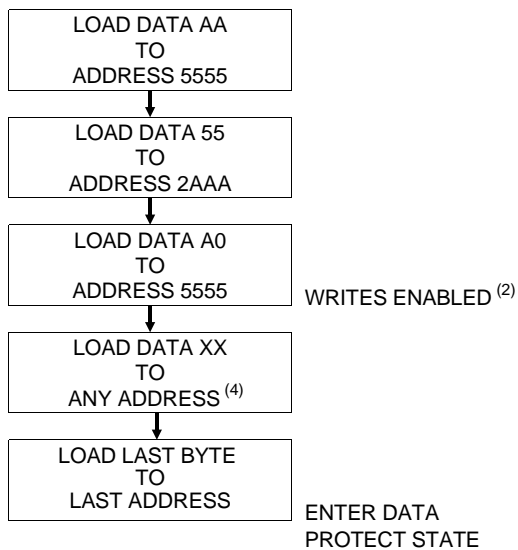

Software Data Protection Disable Algorithm ⁽¹⁾

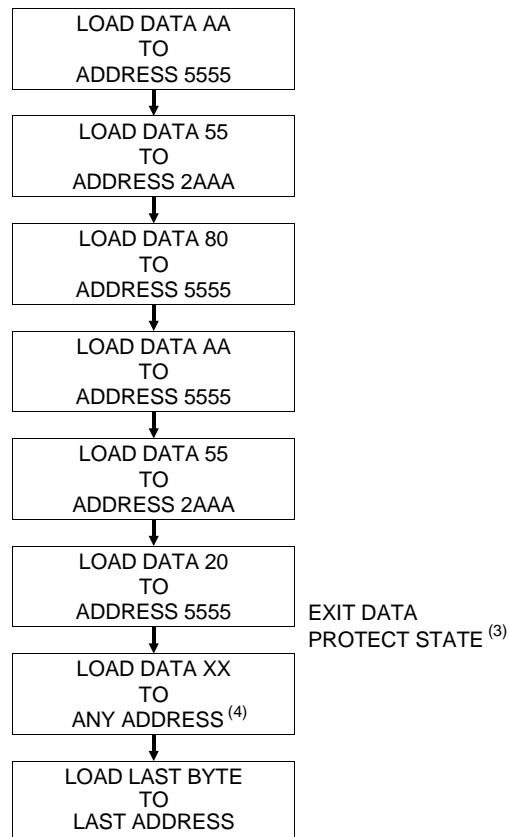

Notes:

1. Data Format: I/O7 - I/O0 (Hex); Address Format: A14 - A0 (Hex).
2. Write Protect state will be activated at end of write even if no other data is loaded.
3. Write Protect state will be deactivated at end of write period even if no other data is loaded.
4. 1 to 64-bytes of data are loaded.

Software Protected Write Cycle Waveforms ^(1, 2)

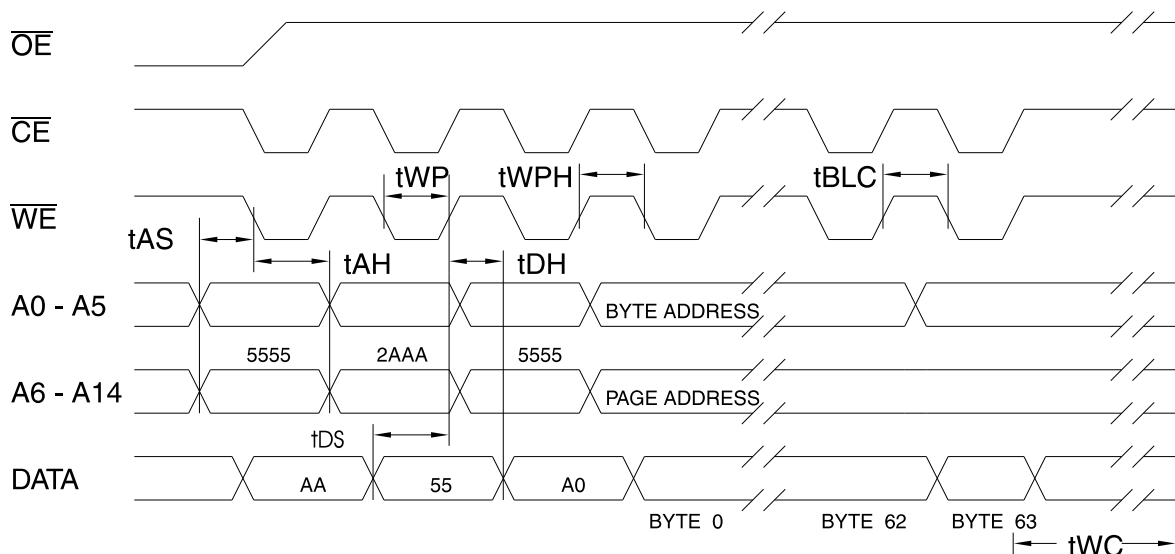

- Notes:
1. A6 through A14 must specify the same page address during each high to low transition of \overline{WE} (or \overline{CE}) after the software code has been entered.
 2. \overline{OE} must be high only when \overline{WE} and \overline{CE} are both low.

Data Polling Characteristics ⁽¹⁾

| Symbol | Parameter | Min | Typ | Max | Units |
|-------------------------------------|--|-----|-----|-----|-------|
| t _{DH} | Data Hold Time | 0 | | | ns |
| t _{OE\bar{H}} | \overline{OE} Hold Time | 0 | | | ns |
| t _{OE} | \overline{OE} to Output Delay ⁽²⁾ | | | | ns |
| t _{WR} | Write Recovery Time | 0 | | | ns |

Notes: 1. These parameters are characterized and not 100% tested.

2. See AC Read Characteristics.

Data Polling Waveforms

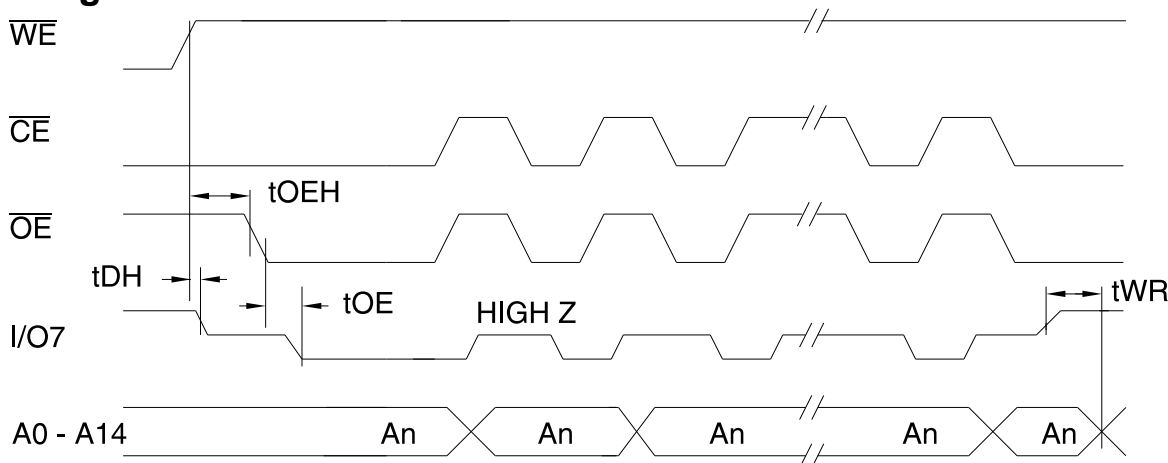

Toggle Bit Characteristics ⁽¹⁾

| Symbol | Parameter | Min | Typ | Max | Units |
|-------------------------------------|--|-----|-----|-----|-------|
| t _{DH} | Data Hold Time | 10 | | | ns |
| t _{OE\bar{H}} | \overline{OE} Hold Time | 10 | | | ns |
| t _{OE} | \overline{OE} to Output Delay ⁽²⁾ | | | | ns |
| t _{OEHP} | \overline{OE} High Pulse | 150 | | | ns |
| t _{WR} | Write Recovery Time | 0 | | | ns |

Notes: 1. These parameters are characterized and not 100% tested.

2. See AC Read Characteristics.

Toggle Bit Waveforms

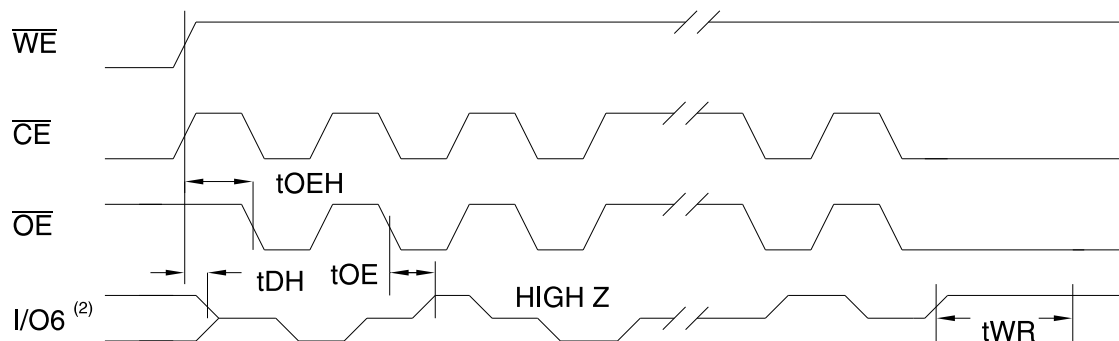

Notes: 1. Toggling either \overline{OE} or \overline{CE} or both \overline{OE} and \overline{CE} will operate toggle bit.

2. Beginning and ending state of I/O6 will vary

3. Any address location may be used but the address should not vary.

NORMALIZED SUPPLY CURRENT vs. TEMPERATURE

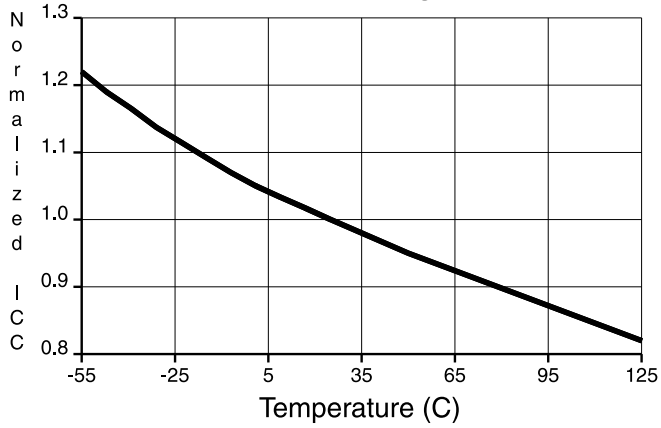

NORMALIZED SUPPLY CURRENT vs. SUPPLY VOLTAGE

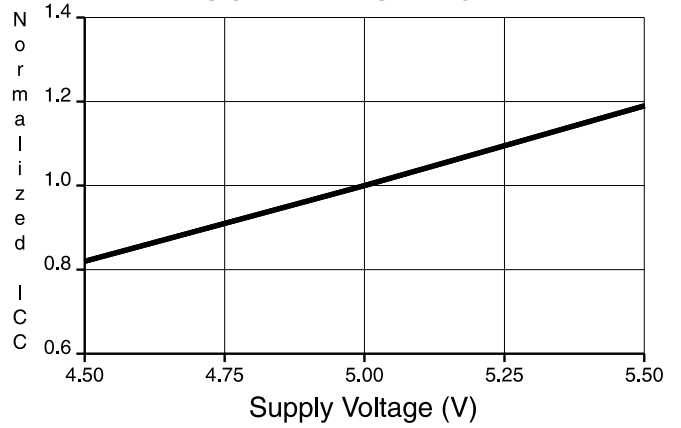

NORMALIZED SUPPLY CURRENT vs. ADDRESS FREQUENCY

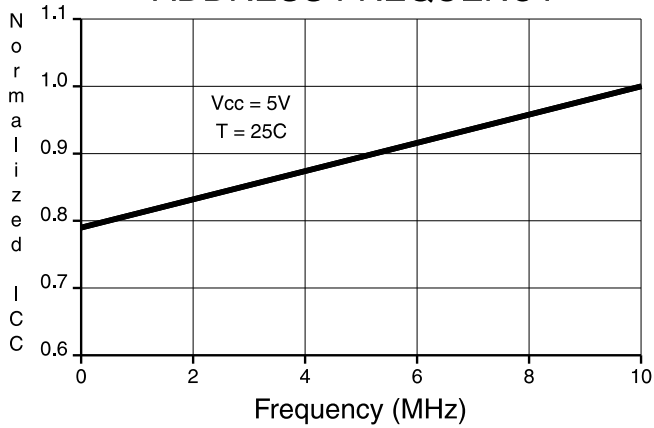

Ordering Information ⁽¹⁾

| t _{ACC} (ns) | I _{CC} (mA) | | Ordering Code | Package | Operation Range |
|--------------------------|----------------------|---------|--|---------------------------|---|
| | Active | Standby | | | |
| 70 | 80 | 60 | AT28HC256(E,F)-70JC AT28HC256(E,F)-70PC | 32J 28P6 | Commercial (0°C to 70°C) |
| | 80 | 0.3 | AT28HC256(E,F)-70JI AT28HC256(E,F)-70PI | 32J 28P6 | Industrial (-40°C to 85°C) |
| 90 | 80 | 0.3 | AT28HC256(E,F)-90JC AT28HC256(E,F)-90PC | 32J 28P6 | Commercial (0°C to 70°C) |
| | 80 | 0.3 | AT28HC256(E,F)-90JI AT28HC256(E,F)-90PI | 32J 28P6 | Industrial (-40°C to 85°C) |
| | 80 | 0.3 | AT28HC256(E,F)-90DM/883 AT28HC256(E,F)-90FM/883 AT28HC256(E,F)-90LM/883 AT28HC256(E,F)-90UM/883 | 28D6 28F 32L 28U | Military/883C Class B, Fully Compliant (-55°C to 125°C) |
| 120 | 80 | 0.3 | AT28HC256(E,F)-12JC AT28HC256(E,F)-12PC AT28HC256(E,F)-12SC AT28HC256(E,F)-12TC | 32J 28P6 28S 28T | Commercial (0°C to 70°C) |
| | 80 | 0.3 | AT28HC256(E,F)-12JI AT28HC256(E,F)-12PI AT28HC256(E,F)-12SI AT28HC256(E,F)-12TI | 32J 28P6 28S 28T | Industrial (-40°C to 85°C) |
| | 80 | 0.3 | AT28HC256(E,F)-12DM/883 AT28HC256(E,F)-12FM/883 AT28HC256(E,F)-12LM/883 AT28HC256(E,F)-12UM/883 | 28D6 28F 32L 28U | Military/883C Class B, Fully Compliant (-55°C to 125°C) |
| 90 | 80 | 0.3 | 5962-88634 03 UX 5962-88634 03 XX 5962-88634 03 YX 5962-88634 03 ZX | 28U 28D6 32L 28F | Military/883C Class B, Fully Compliant (-55°C to 125°C) |
| | 80 | 0.3 | 5962-88634 04 UX 5962-88634 04 XX 5962-88634 04 YX 5962-88634 04 ZX | 28U 28D6 32L 28F | Military/883C Class B, Fully Compliant (-55°C to 125°C) |
| 120 | 80 | 0.3 | 5962-88634 01 UX 5962-88634 01 XX 5962-88634 01 YX 5962-88634 01 ZX | 28U 28D6 32L 28F | Military/883C Class B, Fully Compliant (-55°C to 125°C) |
| | 80 | 0.3 | 5962-88634 02 UX 5962-88634 02 XX 5962-88634 02 YX 5962-88634 02 ZX | 28U 28D6 32L 28F | Military/883C Class B, Fully Compliant (-55°C to 125°C) |

Note: 1. See Valid Part Number table below.



Ordering Information Note

Previous data sheets included the low power suffixes L, LE and LF on the AT28HC256 for 120 ns and 90 ns speeds. The low power parameters are now *standard*; therefore, the L, LE and LF suffixes are no longer required.

Valid Part Numbers

The following table lists standard Atmel products that can be ordered.

| Device Numbers | Speed | Package and Temperature Combinations |
|----------------|-------|--|
| AT28HC256 | 70 | JC, JI, PC, PI |
| AT28HC256 | 90 | JC, JI, PC, PI, TC, TI, DM/883, FM/883, UM/883 |
| AT28HC256E | 90 | JC, JI, PC, PI, TC, TI, DM/883, FM/883, UM/883 |
| AT28HC256F | 90 | JC, JI, PC, PI, TC, TI, DM/883, FM/883, UM/883 |
| AT28HC256 | 12 | JC, JI, PC, PI, TC, TI, DM/883, FM/883, UM/883 |
| AT28HC256E | 12 | JC, JI, PC, PI, TC, TI, DM/883, FM/883, UM/883 |
| AT28HC256F | 12 | JC, JI, PC, PI, TC, TI, DM/883, FM/883, UM/883 |

| Package Type | |
|--------------|--|
| 28D6 | 28 Lead, 0.600" Wide, Non-Windowed, Ceramic Dual Inline Package (Cerdip) |
| 28F | 28 Lead, Non-Windowed, Ceramic Bottom-Brazed Flat Package (Flatpack) |
| 32J | 32 Lead, Plastic J-Leaded Chip Carrier (PLCC) |
| 32L | 32 Pad, Non-Windowed, Ceramic Leadless Chip Carrier (LCC) |
| 28P6 | 28 Lead, 0.600" Wide, Plastic Dual Inline Package (PDIP) |
| 28S | 28 Lead, 0.300" Wide Plastic Gull Wing Small Outline (SOIC) |
| 28T | 28 Lead, Plastic Thin Small Outline Package (TSOP) |
| 28U | 28 Pin, Ceramic Pin Grid Array (PGA) |
| Options | |
| Blank | Standard Device: Endurance = 10K Write Cycles; Write Time = 10 ms |
| E | High Endurance Option: Endurance = 100K Write Cycles |
| F | Fast Write Option: Write Time = 3 ms |

This datasheet has been downloaded from:

www.DatasheetCatalog.com

Datasheets for electronic components.



LittleDiode supplies new, hard to find or obsolete electronic components and semiconductors all over the world.

With over two million different components listed you are sure to find the part you need.

Feel free to visit us today at our online store:

LittleDiode.com

Looking forward to providing you with the best possible service.