

Features

- Fast Read Access Time - 120 ns
- Fast Byte Write - 200 μ s or 1 ms
- Self-Timed Byte Write Cycle
 - Internal Address and Data Latches
 - Internal Control Timer
 - Automatic Clear Before Write
- Direct Microprocessor Control
 - READY/BUSY Open Drain Output
 - DATA Polling
- Low Power
 - 30 mA Active Current
 - 100 μ A CMOS Standby Current
- High Reliability
 - Endurance: 10^4 or 10^5 Cycles
 - Data Retention: 10 Years
- 5V \pm 10% Supply
- CMOS and TTL Compatible Inputs and Outputs
- JEDEC Approved Byte-Wide Pinout
- Commercial and Industrial Temperature Ranges

64K (8K x 8)
CMOS
E²PROM

Description

The AT28C64 is a low-power, high-performance 8,192 words by 8 bit nonvolatile Electrically Erasable and Programmable Read Only Memory with popular, easy to use features. The device is manufactured with Atmel's reliable nonvolatile technology.

(continued)

Pin Configurations

Pin Name	Function
A0 - A12	Addresses
\overline{CE}	Chip Enable
\overline{OE}	Output Enable
\overline{WE}	Write Enable
I/O0 - I/O7	Data Inputs/Outputs
RDY/BUSY	Ready/Busy Output
NC	No Connect
DC	Don't Connect

PDIP, SOIC
Top View

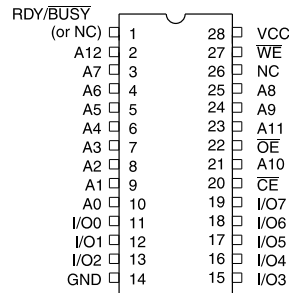

LCC, PLCC
Top View

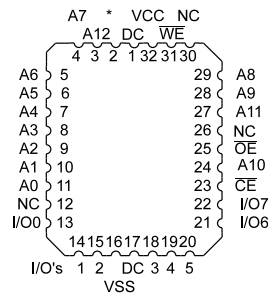

* = RDY/BUSY (or NC)

Note: PLCC package pins 1 and 17 are DON'T CONNECT.

TSOP
Top View

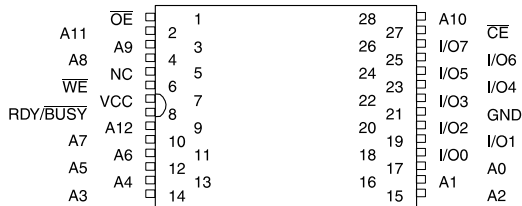

0001G

Description (Continued)

The AT28C64 is accessed like a Static RAM for the read or write cycles without the need for external components. During a byte write, the address and data are latched internally, freeing the microprocessor address and data bus for other operations. Following the initiation of a write cycle, the device will go to a busy state and automatically clear and write the latched data using an internal control timer. The device includes two methods for detecting the end of a write cycle, level detection of RDY/BUSY (unless pin 1 is N.C.) and DATA POLLING of I/O₇. Once the end of a write cycle has been detected, a new access for a read or write can begin.

The CMOS technology offers fast access times of 120 ns at low power dissipation. When the chip is deselected the standby current is less than 100 μ A.

Atmel's 28C64 has additional features to ensure high quality and manufacturability. The device utilizes error correction internally for extended endurance and for improved data retention characteristics. An extra 32-bytes of E²PROM are available for device identification or tracking.

Block Diagram

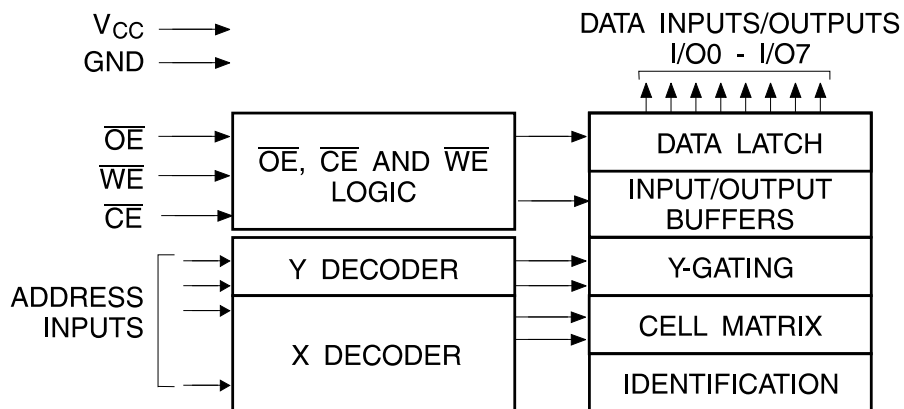

Absolute Maximum Ratings*

Temperature Under Bias.....	-55°C to +125°C
Storage Temperature.....	-65°C to +150°C
All Input Voltages (including NC Pins) with Respect to Ground	-0.6V to +6.25V
All Output Voltages with Respect to Ground	-0.6V to V _{CC} + 0.6V
Voltage on \overline{OE} and A ₉ with Respect to Ground	-0.6V to +13.5V

*NOTICE: Stresses beyond those listed under "Absolute Maximum Ratings" may cause permanent damage to the device. This is a stress rating only and functional operation of the device at these or any other conditions beyond those indicated in the operational sections of this specification is not implied. Exposure to absolute maximum rating conditions for extended periods may affect device reliability.

Device Operation

READ: The AT28C64 is accessed like a Static RAM. When \overline{CE} and \overline{OE} are low and \overline{WE} is high, the data stored at the memory location determined by the address pins is asserted on the outputs. The outputs are put in a high impedance state whenever \overline{CE} or \overline{OE} is high. This dual line control gives designers increased flexibility in preventing bus contention.

BYTE WRITE: Writing data into the AT28C64 is similar to writing into a Static RAM. A low pulse on the \overline{WE} or \overline{CE} input with \overline{OE} high and \overline{CE} or \overline{WE} low (respectively) initiates a byte write. The address location is latched on the falling edge of \overline{WE} (or \overline{CE}); the new data is latched on the rising edge. Internally, the device performs a self-clear before write. Once a byte write has been started, it will automatically time itself to completion. Once a programming operation has been initiated and for the duration of t_{wc}, a read operation will effectively be a polling operation.

FAST BYTE WRITE: The AT28C64E offers a byte write time of 200 μ s maximum. This feature allows the entire device to be rewritten in 1.6 seconds.

READY/BUSY: Pin 1 is an open drain $\overline{RDY/BUSY}$ output that can be used to detect the end of a write cycle. $\overline{RDY/BUSY}$ is actively pulled low during the write cycle and is released at the completion of the write. The open drain connection allows for OR-tying of several devices to the same $\overline{RDY/BUSY}$ line. Pin 1 is not connected for the AT28C64X.

DATA POLLING: The AT28C64 provides $\overline{DATA POLLING}$ to signal the completion of a write cycle. During a write cycle, an attempted read of the data being written results in the complement of that data for I/O₇ (the other outputs are indeterminate). When the write cycle is finished, true data appears on all outputs.

WRITE PROTECTION: Inadvertent writes to the device are protected against in the following ways. (a) V_{CC} sense— if V_{CC} is below 3.8V (typical) the write function is inhibited. (b) V_{CC} power on delay— once V_{CC} has reached 3.8V the device will automatically time out 5 ms (typical) before allowing a byte write. (c) Write Inhibit— holding any one of \overline{OE} low, \overline{CE} high or \overline{WE} high inhibits byte write cycles.

CHIP CLEAR: The contents of the entire memory of the AT28C64 may be set to the high state by the CHIP CLEAR operation. By setting \overline{CE} low and \overline{OE} to 12 volts, the chip is cleared when a 10 msec low pulse is applied to \overline{WE} .

DEVICE IDENTIFICATION: An extra 32-bytes of E²PROM memory are available to the user for device identification. By raising A₉ to 12 \pm 0.5V and using address locations 1FE0H to 1FFFH the additional bytes may be written to or read from in the same manner as the regular memory array.



DC and AC Operating Range

		AT28C64-12	AT28C64-15	AT28C64-20	AT28C64-25
Operating Temperature (Case)	Com.	0°C - 70°C	0°C - 70°C	0°C - 70°C	0°C - 70°C
	Ind.	-40°C - 85°C	-40°C - 85°C	-40°C - 85°C	-40°C - 85°C
V _{CC} Power Supply		5V ± 10%	5V ± 10%	5V ± 10%	5V ± 10%

Operating Modes

Mode	\overline{CE}	\overline{OE}	\overline{WE}	I/O
Read	V _{IL}	V _{IL}	V _{IH}	D _{OUT}
Write ⁽²⁾	V _{IL}	V _{IH}	V _{IL}	D _{IN}
Standby/Write Inhibit	V _{IH}	X ⁽¹⁾	X	High Z
Write Inhibit	X	X	V _{IH}	
Write Inhibit	X	V _{IL}	X	
Output Disable	X	V _{IH}	X	High Z
Chip Erase	V _{IL}	V _H ⁽³⁾	V _{IL}	High Z

Notes: 1. X can be V_{IL} or V_{IH}.

2. Refer to AC Programming Waveforms.

3. V_H = 12.0V ± 0.5V.

DC Characteristics

Symbol	Parameter	Condition	Min	Max	Units
I _{LI}	Input Load Current	V _{IN} = 0V to V _{CC} + 1V		10	μA
I _{LO}	Output Leakage Current	V _{I/O} = 0V to V _{CC}		10	μA
I _{SB1}	V _{CC} Standby Current CMOS	$\overline{CE} = V_{CC} - 0.3V$ to V _{CC} + 1.0V		100	μA
I _{SB2}	V _{CC} Standby Current TTL	$\overline{CE} = 2.0V$ to V _{CC} + 1.0V	Com.	2	mA
			Ind.	3	mA
I _{CC}	V _{CC} Active Current AC	f ≅ 5 MHz; I _{OUT} = 0 mA CE = V _{IL}	Com.	30	mA
			Ind.	45	mA
V _{IL}	Input Low Voltage			0.8	V
V _{IH}	Input High Voltage		2.0		V
V _{OL}	Output Low Voltage	I _{OL} = 2.1 mA = 4.0 mA for RDY/ \overline{BUSY}		.45	V
V _{OH}	Output High Voltage	I _{OH} = -400 μA	2.4		V

AC Read Characteristics

Symbol	Parameter	AT28C64-12		AT28C64-15		AT28C64-20		AT28C64-25		Units
		Min	Max	Min	Max	Min	Max	Min	Max	
t_{ACC}	Address to Output Delay		120		150		200		250	ns
$t_{CE}^{(1)}$	\overline{CE} to Output Delay		120		150		200		250	ns
$t_{OE}^{(2)}$	\overline{OE} to Output Delay	10	60	10	70	10	80	10	100	ns
$t_{DF}^{(3,4)}$	\overline{CE} or \overline{OE} High to Output Float	0	45	0	50	0	55	0	60	ns
t_{OH}	Output Hold from \overline{OE} , \overline{CE} or Address, whichever occurred first	0		0		0		0		ns

AC Read Waveforms (1, 2, 3, 4)

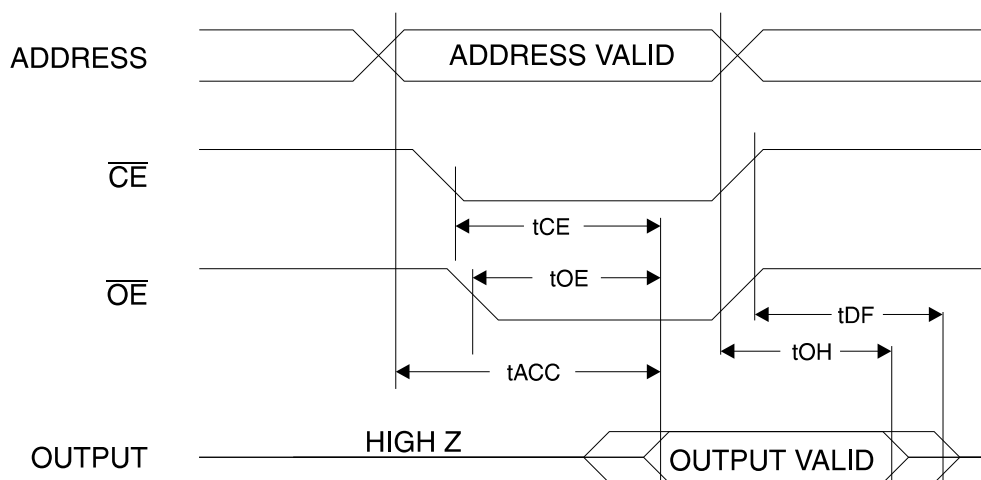

- Notes:
- \overline{CE} may be delayed up to $t_{ACC} - t_{CE}$ after the address transition without impact on t_{ACC} .
 - \overline{OE} may be delayed up to $t_{CE} - t_{OE}$ after the falling edge of \overline{CE} without impact on t_{CE} or by $t_{ACC} - t_{OE}$ after an address change without impact on t_{ACC} .

- t_{DF} is specified from \overline{OE} or \overline{CE} whichever occurs first ($C_L = 5 \text{ pF}$).
- This parameter is characterized and is not 100% tested.

Input Test Waveforms and Measurement Level

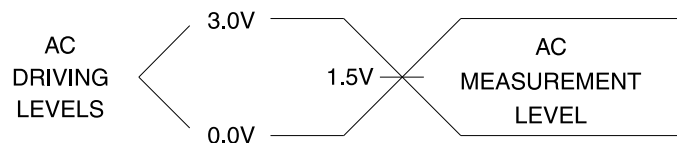

$t_R, t_F < 20 \text{ ns}$

Pin Capacitance ($f = 1 \text{ MHz}$, $T = 25^\circ\text{C}$)⁽¹⁾

	Typ	Max	Units	Conditions
C_{IN}	4	6	pF	$V_{IN} = 0V$
C_{OUT}	8	12	pF	$V_{OUT} = 0V$

Note: 1. This parameter is characterized and is not 100% tested.

Output Test Load

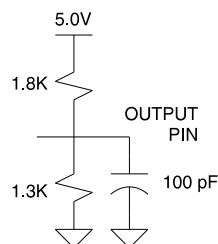

AC Write Characteristics

Symbol	Parameter	Min	Max	Units
t_{AS}, t_{OES}	Address, \overline{OE} Set-up Time	10		ns
t_{AH}	Address Hold Time	50		ns
t_{WP}	Write Pulse Width (\overline{WE} or \overline{CE})	100	1000	ns
t_{DS}	Data Set-up Time	50		ns
t_{DH}, t_{OEH}	Data, \overline{OE} Hold Time	10		ns
t_{CS}, t_{CH}	\overline{CE} to \overline{WE} and \overline{WE} to \overline{CE} Set-up and Hold Time	0		ns
t_{DB}	Time to Device Busy		50	ns
t_{WC}	Write Cycle Time	AT28C64		1.0
		AT28C64E		200
				μs

AC Write Waveforms

\overline{WE} Controlled

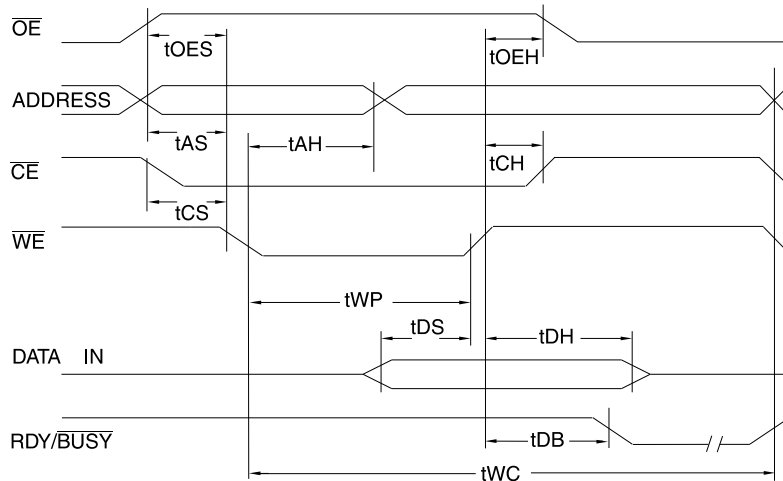

\overline{CE} Controlled

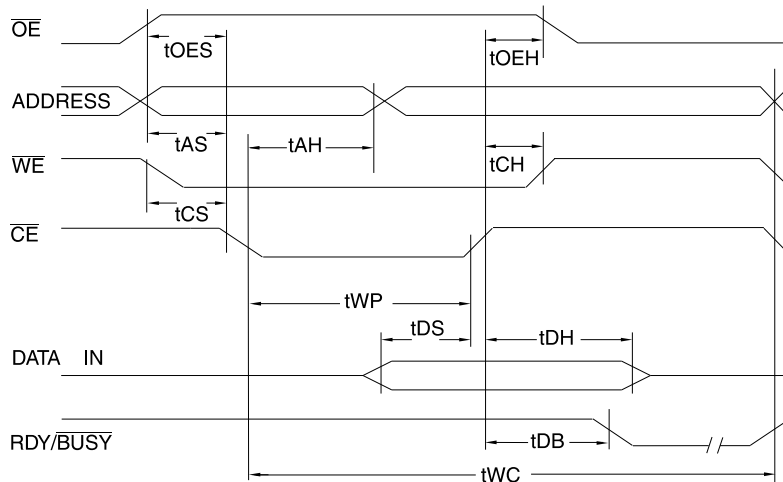

Data Polling Characteristics⁽¹⁾

Symbol	Parameter	Min	Typ	Max	Units
t _{DH}	Data Hold Time	10			ns
t _{OEH}	$\overline{\text{OE}}$ Hold Time	10			ns
t _{OE}	$\overline{\text{OE}}$ to Output Delay ⁽²⁾				ns
t _{WR}	Write Recovery Time	0			ns

Notes: 1. These parameters are characterized and not 100% tested.
 2. See AC Read Characteristics.

Data Polling Waveforms

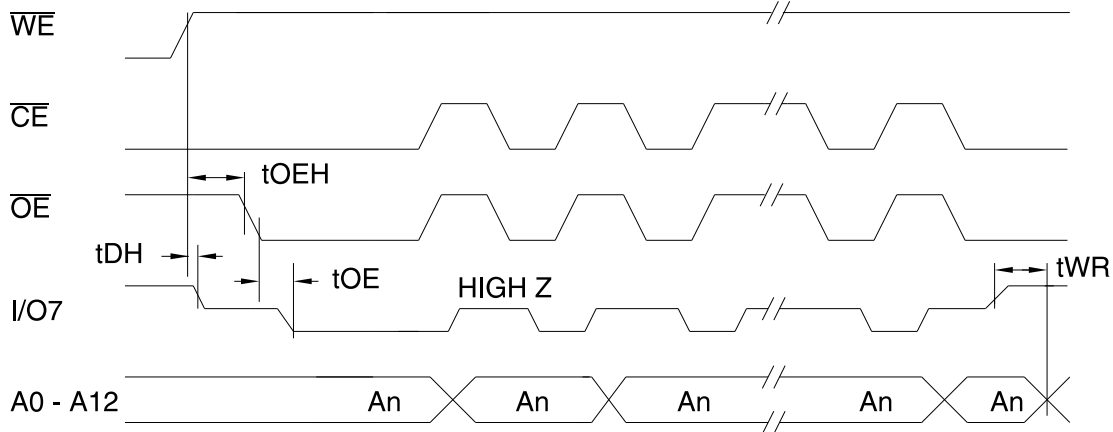

Chip Erase Waveforms

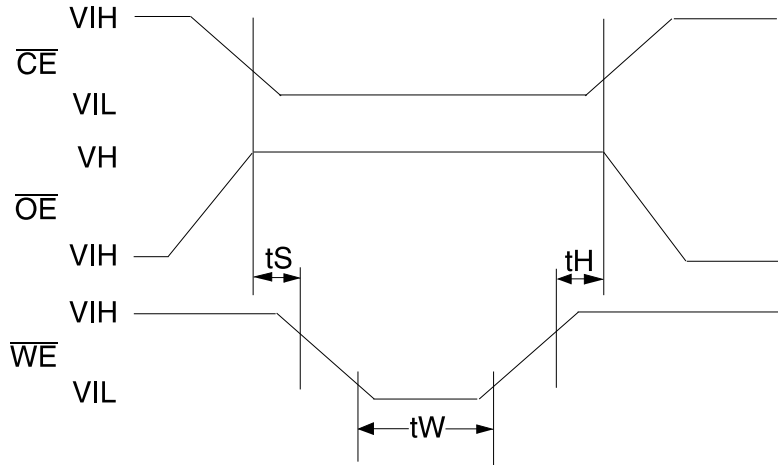

t_S = t_H = 1 μsec (min.)
 t_W = 10 msec (min.)
 V_H = 12.0V ± 0.5V

NORMALIZED SUPPLY CURRENT vs. TEMPERATURE

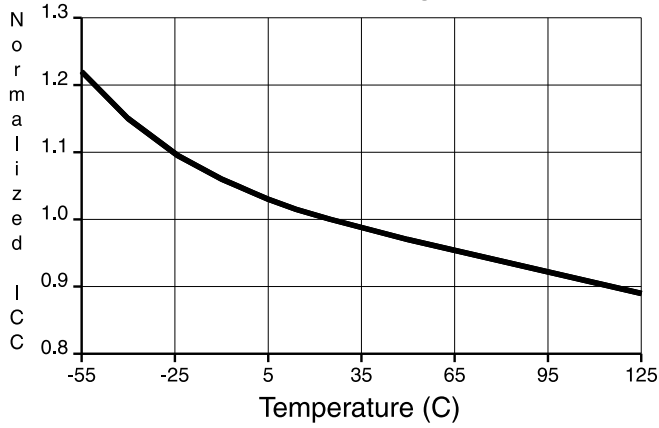

NORMALIZED SUPPLY CURRENT vs. SUPPLY VOLTAGE

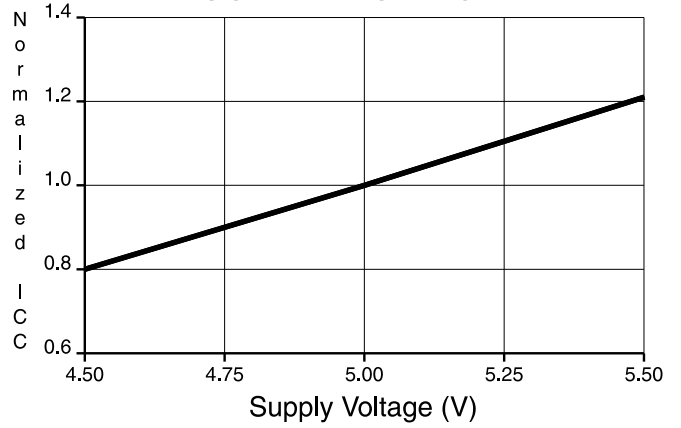

NORMALIZED SUPPLY CURRENT vs. ADDRESS FREQUENCY

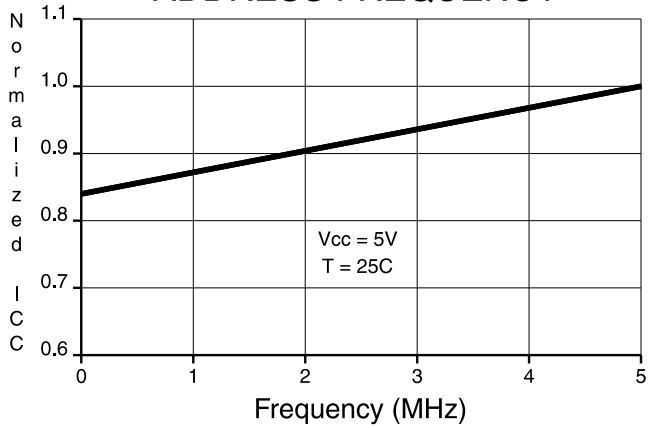

NORMALIZED ACCESS TIME vs. OUTPUT LOAD

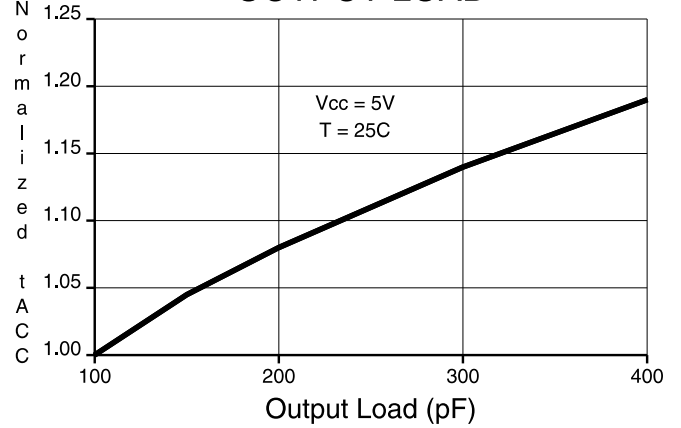

OUTPUT SINK CURRENT vs. OUTPUT VOLTAGE

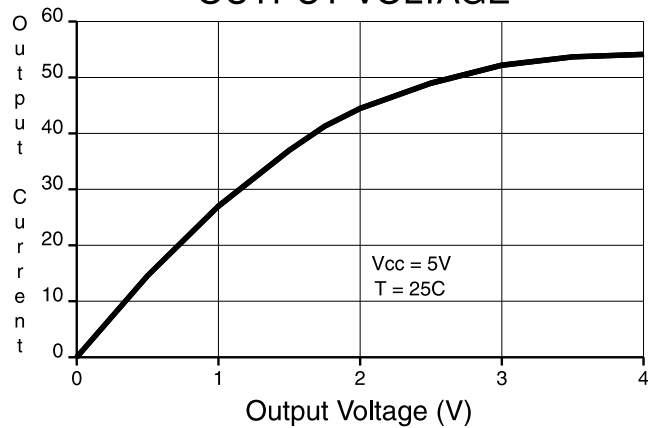

OUTPUT SOURCE CURRENT vs. OUTPUT VOLTAGE

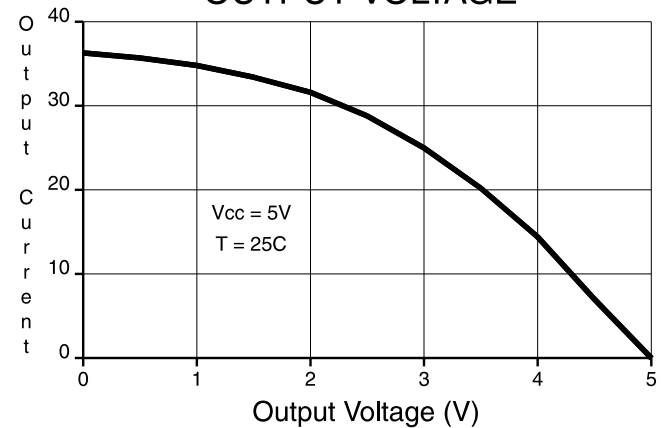

Ordering Information ⁽¹⁾

t _{ACC} (ns)	I _{CC} (mA)		Ordering Code	Package	Operation Range
	Active	Standby			
120	30	0.1	AT28C64(E)-12JC AT28C64(E)-12PC AT28C64(E)-12SC AT28C64(E)-12TC	32J 28P6 28S 28T	Commercial (0°C to 70°C)
	45	0.1	AT28C64(E)-12JI AT28C64(E)-12PI AT28C64(E)-12SI AT28C64(E)-12TI	32J 28P6 28S 28T	Industrial (-40°C to 85°C)
150	30	0.1	AT28C64(E)-15JC AT28C64(E)-15PC AT28C64(E)-15SC AT28C64(E)-15TC	32J 28P6 28S 28T	Commercial (0°C to 70°C)
	45	0.1	AT28C64(E)-15JI AT28C64(E)-15PI AT28C64(E)-15SI AT28C64(E)-15TI	32J 28P6 28S 28T	Industrial (-40°C to 85°C)
200	30	0.1	AT28C64(E)-20JC AT28C64(E)-20PC AT28C64(E)-20SC AT28C64(E)-20TC	32J 28P6 28S 28T	Commercial (0°C to 70°C)
	45	0.1	AT28C64(E)-20JI AT28C64(E)-20PI AT28C64(E)-20SI AT28C64(E)-20TI	32J 28P6 28S 28T	Industrial (-40°C to 85°C)
250	30	0.1	AT28C64(E)-25JC AT28C64(E)-25PC AT28C64(E)-25SC AT28C64(E)-25TC AT28C64-W	32J 28P6 28S 28T DIE	Commercial (0°C to 70°C)
	45	0.1	AT28C64(E)-25JI AT28C64(E)-25PI AT28C64(E)-25SI AT28C64(E)-25TI	32J 28P6 28S 28T	Industrial (-40°C to 85°C)

Note: 1. See Valid Part Number table below.



Package Type	
32J	32 Lead, Plastic J-Leaded Chip Carrier (PLCC)
28P6	28 Lead, 0.600" Wide, Plastic Dual Inline Package (PDIP)
28S	28 Lead, 0.300" Wide, Plastic Gull Wing, Small Outline (SOIC)
28T	28 Lead, Plastic Thin Small Outline Package (TSOP)
W	Die
Options	
Blank	Standard Device: Endurance = 10K Write Cycles; Write Time = 1 ms
E	High Endurance Option: Endurance = 100K Write Cycles; Write Time = 200 μ s

Ordering Information

t _{ACC} (ns)	I _{CC} (mA)		Ordering Code	Package	Operation Range
	Active	Standby			
150	30	0.1	AT28C64X-15JC AT28C64X-15PC AT28C64X-15SC AT28C64X-15TC	32J 28P6 28S 28T	Commercial (0°C to 70°C)
	45	0.1	AT28C64X-15JI AT28C64X-15PI AT28C64X-15SI AT28C64X-15TI	32J 28P6 28S 28T	Industrial (-40°C to 85°C)
200	30	0.1	AT28C64X-20JC AT28C64X-20PC AT28C64X-20SC AT28C64X-20TC	32J 28P6 28S 28T	Commercial (0°C to 70°C)
	45	0.1	AT28C64X-20JI AT28C64X-20PI AT28C64X-20SI AT28C64X-20TI	32J 28P6 28S 28T	Industrial (-40°C to 85°C)
250	30	0.1	AT28C64X-25JC AT28C64X-25PC AT28C64X-25SC AT28C64X-25TC	32J 28P6 28S 28T	Commercial (0°C to 70°C)
	45	0.1	AT28C64X-25JI AT28C64X-25PI AT28C64X-25SI AT28C64X-25TI	32J 28P6 28S 28T	Industrial (-40°C to 85°C)

Valid Part Numbers

The following table lists standard Atmel products that can be ordered.

Device Numbers	Speed	Package and Temperature Combinations
AT28C64 X	12	JC, JI, PC, PI, SC, SI, TC, TI
AT28C64 X	15	JC, JI, PC, PI, SC, SI, TC, TI
AT28C64 X	20	JC, JI, PC, PI, SC, SI, TC, TI
AT28C64 X	25	JC, JI, PC, PI, SC, SI, TC, TI

Package Type	
32J	32 Lead, Plastic J-Leaded Chip Carrier (PLCC)
28P6	28 Lead, 0.600" Wide Plastic Dual Inline Package (PDIP)
28S	28 Lead, 0.300" Wide, Plastic Gull Wing Small Outline (SOIC)
28T	28 Lead, Plastic Thin Small Outline Package (TSOP)

This datasheet has been downloaded from:

www.DatasheetCatalog.com

Datasheets for electronic components.



LittleDiode supplies new, hard to find or obsolete electronic components and semiconductors all over the world.

With over two million different components listed you are sure to find the part you need.

Feel free to visit us today at our online store:

LittleDiode.com

Looking forward to providing you with the best possible service.