



## ST7 SERIAL TEST CONTROLLER PROGRAMMING

---

by Microcontroller Division Applications

### INTRODUCTION

This application note describes:

- The advantages of Serial Test Controller Programming (STCP) vs. programming using an EPROM programming board (EPB) (see Section 2.1).
- How to implement Serial Test Controller Programming targeting most of the ST7 general purpose microcontrollers (see Section 2.2). These devices include all parts supported by the ST7 starter kits and ST7 EPBs in the MDT1, MDT2 and MDT4 tool families (see the supported device list in APPENDIX 1).

**Note:** In this application note, the term “programming tool” refers to either the EPBs or the starter kits.

### 1 PROGRAMMING TECHNIQUES

There are two possible ways of programming an ST7 device:

- Using a programming tool. In this case, the device is first plugged on the programming board and then programmed. Then, the part is soldered or plugged into a socket on the user board. This can be done using any of the following ST7 programming tools:
  - ST7 Starter Kit
  - ST7 EPB (EPROM Programming Board)
  - ST7 Gang Programmer

For further details about the above tools, please refer to the user manual supplied with these devices.

- Using a Serial Test Controller Programming (STCP) tool. This technique allows a device to be directly programmed on the user board. This is a two-step procedure where first the board is first manufactured with a blank ST7, and afterwards the chip is programmed using a programming tool (Starter Kit or EPB).

This application note describes the STCP method only.

## 2 SERIAL TEST CONTROLLER PROGRAMMING

### 2.1 ADVANTAGES

The advantages of STCP are numerous:

- Time to market

To reduce manufacturing cycle times, a user board can be designed to be generic, supporting several functions. These functions can be enabled or disabled by software according to customer requirements. In this case, STCP allows application boards to be manufactured in one shot and programmed with different functions according to customer needs and orders.

- Cost reduction

Software updates may be necessary in some cases because of a bug correction or a newly implemented feature. The STCP is a flexible and painless way of performing such modifications and at a lower cost. There is no need to add any sockets to the board or to unsolder and change components in order to upgrade the application.

- Security

Because STCP offers an easy way to customise the user's program, or part of it, it can be used to insert different key codes for each board. This could be used, for example, in a door lock system.

- Flexibility

For example, STCP can be used to allow calibration procedures to be performed directly in the field.

### 2.2 USER BOARD SPECIFICATION

The user has to design his layout in order to support two modes: programming mode and user mode.

Figure 1. shows the user board divided into two blocks:

- Block 1:

Includes all the components that play a role during programming mode:

- Connector J1, which links the user board to the programming tool.
- The ST72 MCU, which is the device to be programmed.
- Jumpers W1 to Wn, whose purpose is to isolate the pins used for programming the ST72 from the other components in Block 2. In some application configurations, isolation resistors (47 kΩ) can be used instead of jumpers.

- Block 2:

This block consists of all the other components soldered on the user board.

Figure 1. User Board

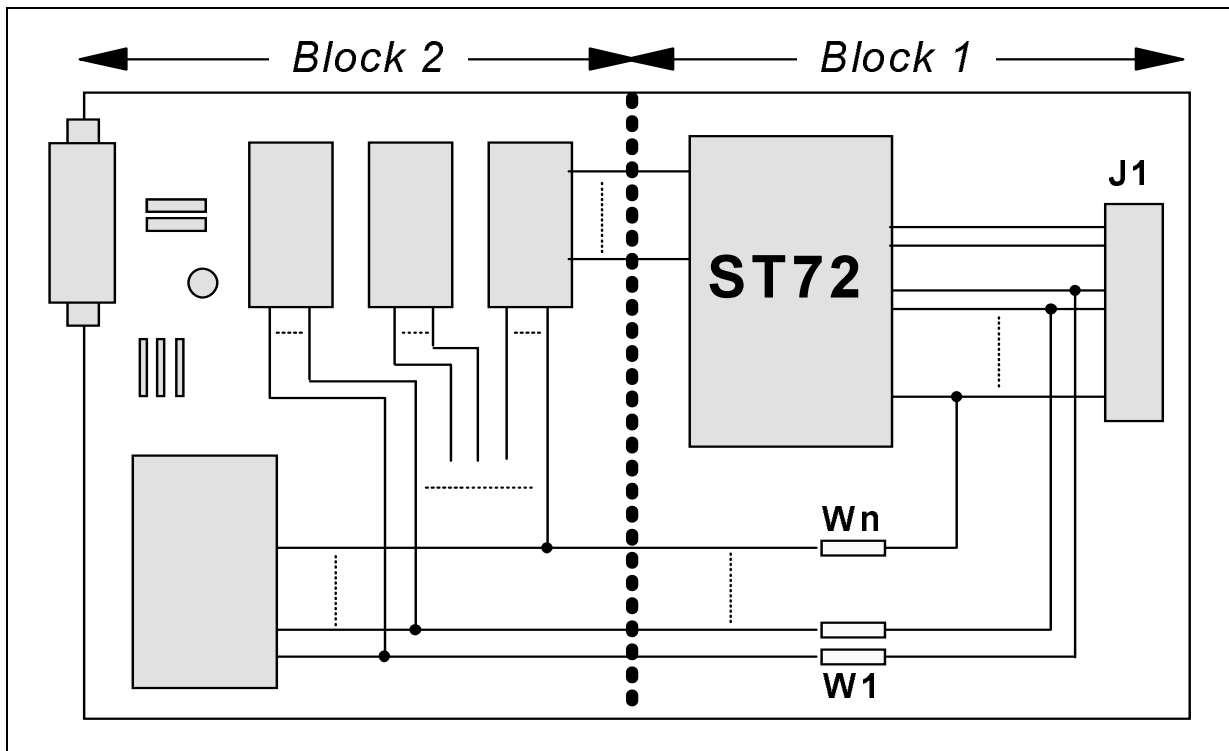

Now, let's define the pins used for programming the ST7. These pins are put together in the W1 connector implemented in all the ST programming tool boards (see Section 3 APPENDIX 1 for the pin connector assignment).

All the ST7 programming tools referred to in this note (ST7 starter kits and ST7 EPBs in the MDT1, MDT3 and MDT4 tool families) use a programming technique called JTAG (Joint Test Action Group).

These programming tools control 11 pins:

- 5 JTAG pins and 3 test mode pins, which are used for loading the software code into the ST7. These pins are:
  - Pin TCK: the test clock (input),
  - Pin TMS: the Test Mode Select (input, weak pull-up),
  - Pin TRST0: the Reset (Input, weak pull-up, active low)
  - Pin TDI: the Test Data In (input, weak pull-up). This is the serial data input, sampled on the rising edge of TCK.
  - Pin TDO: the Test Data Out (tri-state output). This is the serial data output, updated on the falling edge of TCK.
  - Pins M0, M1 and M2: These 3 pins are used to force the test modes.

Depending on the device selected, these 8 pins will be associated with different pin numbers (see APPENDIX 1).

## ST7 SERIAL TEST CONTROLLER PROGRAMMING

---

If these pins need to be tied to  $V_{DD}$  or  $V_{SS}$ , or if they are used by the user's application, they must be isolated from the user circuitry during programming. To do so, a jumper can be added for each of the eight pins (see Figure 2.).

**Note:** Isolation resistors (47 k $\Omega$ ) can be used instead of jumpers only if these pins are used by the application as input (without Pull-up, without pull-down, or analog input configuration).

- 3 system pins,  $V_{PP}/TEST$ ,  $\overline{RESET}$  and OSCIN, which must be connected as follows:
  - The  $V_{PP}/TEST$  pin must not be directly connected to GND/ $V_{SS}$  on the application board in order to avoid any conflict with the programming voltage. This pin should be pulled down by a 10 k $\Omega$  resistor (see Figure 2.).
  - The  $\overline{RESET}$  pin controls the entry into programming mode. This pin must be connected to a 10 k $\Omega$  pull-up resistor and a 1 nF capacitor connected to GND (see Figure 2.) to avoid any direct connections to  $V_{SS}$ . This pin can be connected to a 47 k $\Omega$  isolation resistor if an external reset is provided by the application board.
  - The OSCIN pin synchronizes the programming operation using a clock generated by the programming tool. The OSCIN pin can be directly connected to the J1 connector. No isolation is needed as long as a quartz crystal or ceramic resonator is used in the application. If an external clock generator is used in the application, it must be disconnected during STC programming.  
**Note:** The OSCOUT pin does not need to be disconnected during the programming phase as long as a crystal, a ceramic resonator or an external clock source is used to drive the internal oscillator (user mode only).
- The  $V_{DD}$  and  $V_{SS}$  power supply pins. The use of the  $V_{DD}$  connection is optional, depending on whether the application board supply can be disconnected or not.

If the application board supply is disconnected, the chip can be supplied through the programming tool (as long as the total current load does not exceed 100 mA and the capacitive load is less than 50  $\mu$ F). In this case, only 1 jumper needs to be added in order to disconnect the  $V_{PP}$  pin from the user circuitry during the programming sequence. No jumper is needed for  $V_{SS}$  (see Figure 2.).

If you want to use the application board power supply, its voltage must be 5 V, so that logic levels are compatible with those of the programming tool.

**Note:** In any case, the ground from the application board and the ground from the programming tool must be connected together (see Figure 2.).

Figure 2. Block 1

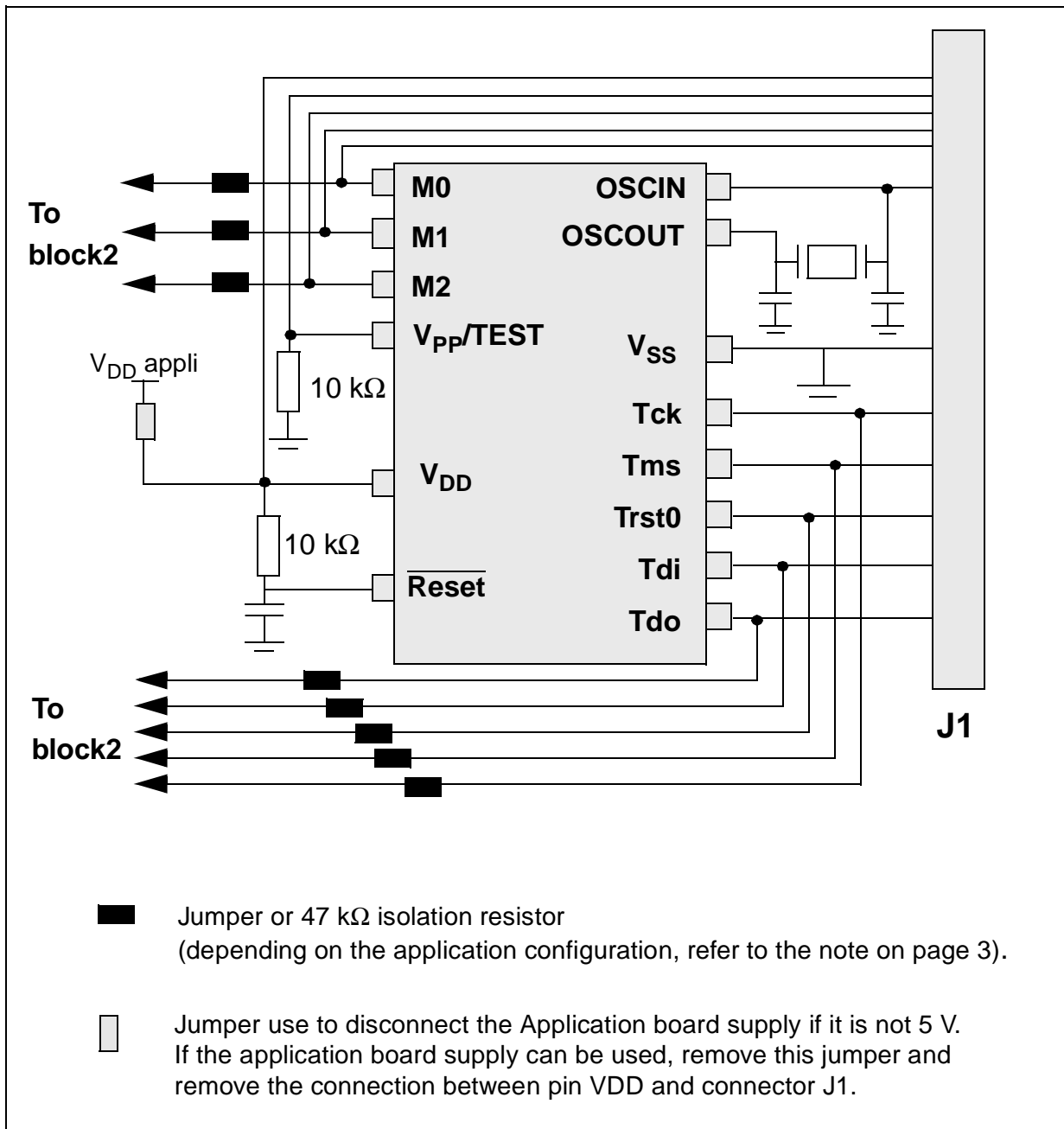

The ST7 programming tool is connected to the user board via connector J1.

### 2.3 PROGRAMMING PROCEDURE

Depending on the device you need to program, use one of these ST7 programming tools:

- ST7 MDT1-KIT or ST7 MDT1-EPB. They cover the following devices:
  - ST72101G1 or G2
  - ST72212G2
  - ST72213G1
  - ST72251G1 or G2
- ST7 MDT2-KIT or ST7 MDT4-EPB. They cover the following devices:
  - ST72121J2 or J4
  - ST72311J2 or J4
  - ST72311N2 or N4
  - ST72331J2 or J4
  - ST72331N2 or N4
- ST7 MDT4-KIT or ST7 MDT4-EPB. They cover the following devices:
  - ST72272K2 or K4
  - ST72372J4
  - ST72371N4
  - ST72671N4 or N6

After selecting the appropriate programming tool, proceed as follows:

1. On the application board, remove all jumpers.
2. Locate the 16 pin connector W1 (8x2 header HE10) on the programming tool which contains the 12 signals necessary for performing STCP (see Section 3 APPENDIX 1 for the pin identification). Then connect the W1 connector of the programming tool to the application board connector (J1 in Figure 1.).
3. Using the parallel interface cable, connect the PC parallel port to the parallel connector of the programming tool.
4. Power on the PC and the board. On the programming tool, LED 1 must light up.
5. Start the Windows EPROMer, target the programming tool, then the correct device. Open the file containing the code to program. And... program your device!
6. Close the operating software, power down the programming tool, disconnect the application board from the programming tool and replace any jumpers that were disconnected on the application board. Your application is now ready to run!

**3 APPENDIX 1**

The following table lists the devices supported by this application note and the specific starter kit required for each sales type.

<b>Sales Type</b>	<b>Starter Kit supporting the device</b>
ST72x101G1	ST7 MDT1 Starter kit or EPB
ST72x101G2	
ST72x212G2	
ST72x213G1	
ST72x251G1	
ST72x251G2	
ST72x121J2	ST7 MDT2 Starter kit or EPB
ST72x121J4	
ST72x311J2	
ST72x311J4	
ST72x311N2	
ST72x311N4	
ST72x331J2	
ST72x331J4	
ST72x331N2	
ST72x331N4	
ST72x272K2	ST7 MDT4 Starter kit or EPB
ST72x272K4	
ST72x371N4	
ST72x372J4	
ST72x671N4	
ST72x671N6	

x = T, if the device is an OTP,  
 E, if the device is an EPROM.

## ST7 SERIAL TEST CONTROLLER PROGRAMMING

### 4 APPENDIX 2

This appendix provides the required information for programming a device supported by the MDT1, MDT2 and MDT4 EPBs or starter kits. The five JTAG pins and three test mode pins (M0, M1 and M2) with their associated pin numbers are specified for each device.

#### 4.1 ST7 MDT1 EPB OR STARTER KIT

ST7 Device					Pin Numbers													
Sales type	EPROM	E <sup>2</sup>	RAM	Package	JTDI	JTCK	JTRST	JTMS	JTDO	M2	M1	M0	Vpp	Reset	Oscin	Vdd	Vss	
					PA3	PA2	PA1	PA0	PC3	PB2	PB1	PB0						
ST72x101G1	4K	-	256	SO28 SDIP32	22 26	23 27	24 28	25 29	14 16	9 11	10 12	11 13	26 30	1 1	2 2	28 32	27 31	
ST72x101G2	8K	-	256	SO28 SDIP32	22 26	23 27	24 28	25 29	14 16	9 11	10 12	11 13	26 30	1 1	2 2	28 32	27 31	
ST72x212G2	8K	-	256	SO28 SDIP32	22 26	23 27	24 28	25 29	14 16	9 11	10 12	11 13	26 30	1 1	2 2	28 32	27 31	
ST72x213G1	4K	-	256	SO28 SDIP32	22 26	23 27	24 28	25 29	14 16	9 11	10 12	11 13	26 30	1 1	2 2	28 32	27 31	
ST72x251G1	4K	-	256	SO28 SDIP32	22 26	23 27	24 28	25 29	14 16	9 11	10 12	11 13	26 30	1 1	2 2	28 32	27 31	
ST72x251G2	8K	-	256	SO28 SDIP32	22 26	23 27	24 28	25 29	14 16	9 11	10 12	11 13	26 30	1 1	2 2	28 32	27 31	
Programming tool W1 connector					5	1	9	3	7	12	10	8	16	4	2	N.C	15	

x = T, if the device is an OTP,  
 E, if the device is an EPROM,  
 N.C., means not connected.

## ST7 SERIAL TEST CONTROLLER PROGRAMMING

### 4.2 ST7 MDT2 EPB OR STARTER KIT

ST7 Device					Pin Numbers											
Sales type	EPROM	E <sup>2</sup>	RAM	Package	JTDI PA7	JTCK PA6	JTRST PA5	JTMS PA4	JTDO PA3	M2 PB2	M1 PB1	M0 PB0	Vpp	Reset	Oscin	
ST72x121J2	8K	-	384	TQFP44 SDIP42	37 30	36 29	35 28	34 27	31 24	4 41	3 40	2 39	38 31	39 32	42 35	
ST72x121J4	16K	-	512	TQFP44 SDIP42	37 30	36 29	35 28	34 27	31 24	4 41	3 40	2 39	38 31	39 32	42 35	
ST72x311J2	8K	-	384	TQFP44 SDIP42	37 30	36 29	35 28	34 27	31 24	4 41	3 40	2 39	38 31	39 32	42 35	
ST72x311J4	16K	-	512	TQFP44 SDIP42	37 30	36 29	35 28	34 27	31 24	4 41	3 40	2 39	38 31	39 32	42 35	
ST72x311N2	8K	-	384	TQFP64 SDIP56	52 40	51 39	50 38	49 37	46 34	7 55	6 54	5 53	53 41	54 42	59 45	
ST72x311N4	16K	-	512	TQFP64 SDIP56	52 40	51 39	50 38	49 37	46 34	7 55	6 54	5 53	53 41	54 42	59 45	
ST72x331J2	8K	256	384	TQFP44 SDIP42	37 30	36 29	35 28	34 27	31 24	4 41	3 40	2 39	38 31	39 32	42 35	
ST72x331J4	16K	256	512	TQFP44 SDIP42	37 30	36 29	35 28	34 27	31 24	4 41	3 40	2 39	38 31	39 32	42 35	
ST72x331N2	8K	256	384	TQFP64 SDIP56	52 40	51 39	50 38	49 37	46 34	7 55	6 54	5 53	53 41	54 42	59 45	
ST72x331N4	16K	256	512	TQFP64 SDIP56	52 40	51 39	50 38	49 37	46 34	7 55	6 54	5 53	53 41	54 42	59 45	
Programming tool W1 connector					5	1	9	3	7	12	10	8	16	4	2	

### 4.3 ST7 MDT4 EPB OR STARTER KIT

ST7 Device					Pin Numbers												
Sales type	EPROM	E <sup>2</sup>	RAM	Package	JTDI PA7	JTCK PA6	JTRST PA5	JTMS PA4	JTDO PC6	M2 DA3	M1 DA2	M0 DA1	Vpp	Reset	Oscin	Vdd	Vss
ST72x272K2	8K	-	384	SO34 SDIP32	29 27	30 28	31 29	32 30	25 24	3 3	2 2	1 1	34 32	33 31	28 26	8 8	7 7
ST72x272K2	16K	-	512	SO34 SDIP32	29 27	30 28	31 29	32 30	25 24	3 3	2 2	1 1	34 32	33 31	28 26	8 8	7 7
ST72x371N4	16K	-	512	TQFP64 SDIP56	28 46	29 47	30 48	31 49	20 38	43 3	42 2	41 1	40 56	38 54	27 45	11 31	9 29
ST72x372J4	16K	-	512	SDIP42	34	35	36	37	31	2	1	42	41	40	33	25	23
ST72x671N4	16K	-	512	TQFP64 SDIP56	28 46	29 47	30 48	31 49	20 38	43 3	42 2	41 1	40 56	38 54	27 45	11 31	9 29
ST72x671N6	32K	-	1K	TQFP64 SDIP56	28 46	29 47	30 48	31 49	20 38	43 3	42 2	41 1	40 56	38 54	27 45	11 31	9 29
Programming tool W1 connector					5	1	9	3	7	12	10	8	16	4	2	N.C	15

x = T, if the device is an OTP,  
 E, if the device is an EPROM,  
 N.C., means not connected.

## ST7 SERIAL TEST CONTROLLER PROGRAMMING

---

THE PRESENT NOTE WHICH IS FOR GUIDANCE ONLY AIMS AT PROVIDING CUSTOMERS WITH INFORMATION REGARDING THEIR PRODUCTS IN ORDER FOR THEM TO SAVE TIME. AS A RESULT, STMICROELECTRONICS SHALL NOT BE HELD LIABLE FOR ANY DIRECT, INDIRECT OR CONSEQUENTIAL DAMAGES WITH RESPECT TO ANY CLAIMS ARISING FROM THE CONTENT OF SUCH A NOTE AND/OR THE USE MADE BY CUSTOMERS OF THE INFORMATION CONTAINED HEREIN IN CONNEXION WITH THEIR PRODUCTS."

Information furnished is believed to be accurate and reliable. However, STMicroelectronics assumes no responsibility for the consequences of use of such information nor for any infringement of patents or other rights of third parties which may result from its use. No license is granted by implication or otherwise under any patent or patent rights of STMicroelectronics. Specifications mentioned in this publication are subject to change without notice. This publication supersedes and replaces all information previously supplied. STMicroelectronics products are not authorized for use as critical components in life support devices or systems without the express written approval of STMicroelectronics.

The ST logo is a registered trademark of STMicroelectronics

©2000 STMicroelectronics - All Rights Reserved.

Purchase of I<sup>2</sup>C Components by STMicroelectronics conveys a license under the Philips I<sup>2</sup>C Patent. Rights to use these components in an I<sup>2</sup>C system is granted provided that the system conforms to the I<sup>2</sup>C Standard Specification as defined by Philips.

STMicroelectronics Group of Companies

Australia - Brazil - China - Finland - France - Germany - Hong Kong - India - Italy - Japan - Malaysia - Malta - Morocco - Singapore - Spain  
Sweden - Switzerland - United Kingdom - U.S.A.

<http://www.st.com>



LittleDiode supplies new, hard to find or obsolete electronic components and semiconductors all over the world.

With over two million different components listed you are sure to find the part you need.

Feel free to visit us today at our online store:

[LittleDiode.com](http://LittleDiode.com)

Looking forward to providing you with the best possible service.