

## TSM101 USED IN A LINEAR BATTERY CHARGER

by S. LAFFONT

This application note shows an example of linear battery charger using the TSM101 integrated circuit.

This charger is used for a six Cells Nickel-cadmium battery.

The charge current is regulated at 200mA (if the charge control input is left open ) or 60mA (if the charge control input is put to ground), allowing the charge of two different types of batteries.

### 1 - TSM101 PRESENTATION

The TSM101 integrated circuit incorporates a high stability series band gap voltage reference, two ORed operational amplifiers and a current source (Figure 1).

The controlled current generator can be used to modify the level of current limitation by offsetting the information coming from the current sensing resistor.

**Figure 1** : TSM101 Schematic Diagram

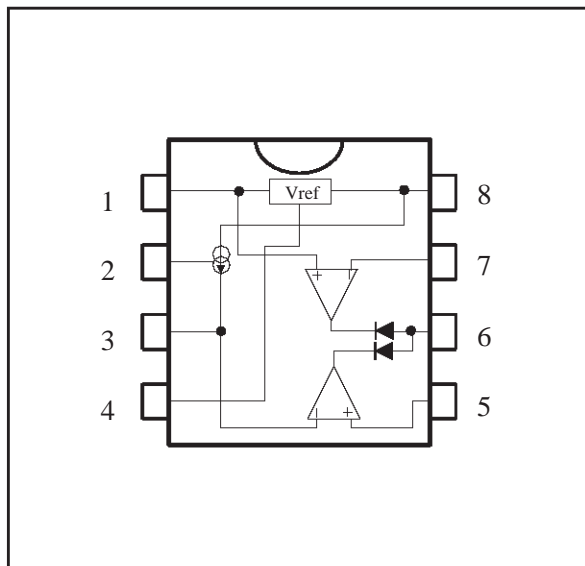

### 2 - CALCULATION OF THE ELEMENTS

#### 2.1 - Voltage limitation

The end-of-charge voltage is limited at 1.45V/cell, this is the recommended voltage for an ambient temperature at 25°C.

D5 avoids the discharge of the battery if the charger is not powered. This diode is sometimes directly integrated in the battery pack. The influence of this diode on the charge is negligible if the voltage drop (0.7V) is taken into account during the design of the charger.

The voltage, on the emitter of transistor Q1 is  $V_{eq1} = (1.45 \times 6) + 0.7V = 9.4V$  and, regarding R6 and R7 :

$$V_{eq1} = \frac{R6+R7}{R6} \cdot V_{ref}$$

P1, which is a part of R6 and R7 is not considered in this equation.

The following values are used on the application board :

- R7 = 10kΩ
- R6 = 1.5kΩ
- P1 = 220Ω, adjust for  $V_{output} = 8.7V$  (on the cathode of D5) with the battery replaced by a 1kΩ resistor
- R10 = short circuit
- C3 = 100nF

#### 2.2 Current regulation

R5 is the sense resistor used for current measurement .

The current regulation is effective when the voltage drop across R5 is equal to the voltage on pin 5 of the TSM101 (assuming that the internal current source is disabled).

For medium currents (<1A), a voltage drop across R5 of 200mV = Vr5 is a good value, R5 can be

## APPLICATION NOTE

realized with standard low cost 0.5W resistor, or with two 0.25W resistors.

R2 and R3 can be chosen using the following formula :

$$R2 = R3 \times \frac{(V_{ref} - V_{r5})}{V_{r5}}$$

### CHARGE CONTROL

If the pin 2 is left open, the charge current is nominal at # 200mA.

If pin 2 is connected to ground, the internal current source is enabled, the current measurement is off-setted by a voltage equal to :

$$V_{r4} = I_o \times R4 \text{ with } I_o = 1.4\text{mA}$$

This can be used to lower the charging current or eventually to stop the charge, if  $V_{r4} > V_{r5}$

In our example, the current offset is equal to  $200 - 60\text{mA} = 140\text{mA}$ , representing a voltage offset  $V_{r4} = 140\text{mV}$  across R4.

The following values are used on the application board :

- R5 = 1Ω 0.5W
  - R4 = 140Ω
  - R2 = 1.2kΩ
  - R3 = 220Ω
  - R9 = short circuit
- R1 = 10kΩ  
 C2 = 100nF  
 C5 = 100nF

### 3 - POWER TRANSISTOR SELECTION

The output voltage (and by consequence, the current) follows the TSM101 output (pin 6). To provide a safe current control, even in case of charger short-circuit, it is necessary to compensate the voltage drop on the ORing diodes integrated in the TSM101.

The output voltage of the TSM101 can't be equal to zero and to overcome this voltage, the best solution is to use a darlington (Q1 + Q2) although the gain of such a device is not necessary in this application.

Q2 is a low cost general purpose small power transistor.

Q1 is a medium power transistor, heat-sinked, capable to dissipate a few Watts in the worst case (output of the charger short-circuited), a "classical" BD135 is a good example.

### 4 - MISCELLANEOUS COMPONENTS

A small 9VAC transformer is used for the application board.

Others components are the following :

- R11 = 1kΩ
- C5 = 100nF
- C1 = 470μF
- R8 = 10kΩ
- C4 = 10μF
- D1....D5 = 1N4004

### SCHEMATIC DIAGRAM

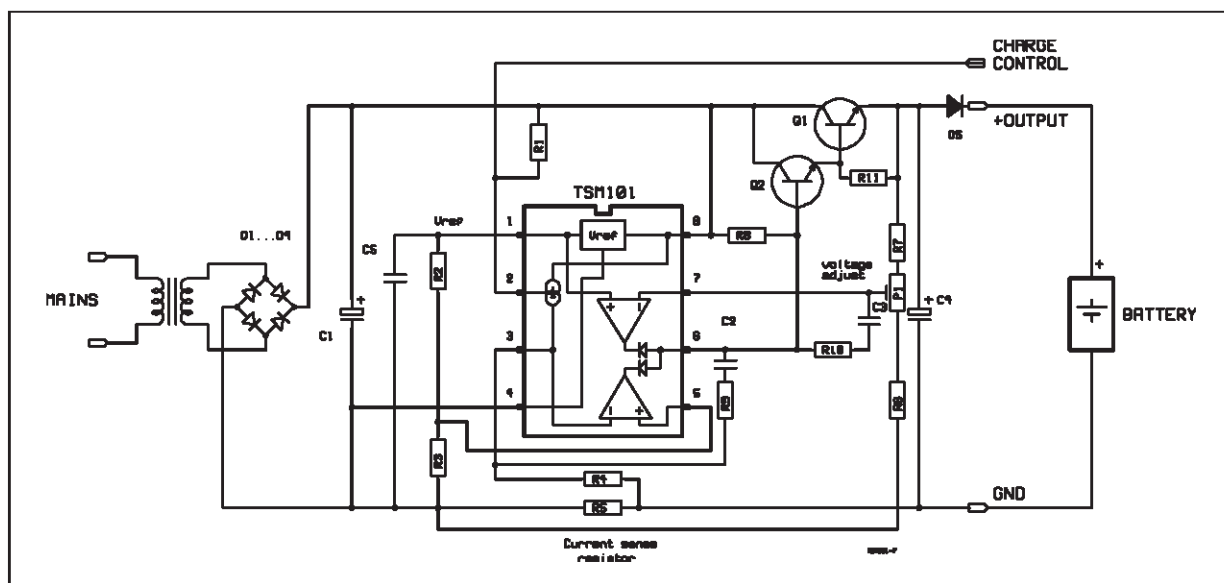





LittleDiode supplies new, hard to find or obsolete electronic components and semiconductors all over the world.

With over two million different components listed you are sure to find the part you need.

Feel free to visit us today at our online store:

[LittleDiode.com](http://LittleDiode.com)

Looking forward to providing you with the best possible service.